

Top 100
Global
Innovator
for 10 years

Susol

AIR CIRCUIT BREAKER

Up to 800/900/1000/1150Vac

For renewable application and high altitude



LS ELECTRIC



Features

- E-Frame: (~ 4000AF)
- D-Frame: (~ 2000AF)
- C-Frame: (~ 1600AF)
- 1150Vac, 1000Vac, 900Vac, 800Vac
- PV market, high altitude area, wind power
- D/E Frame with new OCR (STU)
- Instrumentation precision
 - Current/Voltage: 0.5%
 - Power: Class 1.0

Ampere Frame	AV-20D□		AV-40E□	
	~ 2000AF		~ 4000AF	
Rated current (In) (A) at 40°C (A)	200 / 400 / 630 / 800 / 1000 / 1250 / 1600 / 2000		400 / 630 / 800 / 1000 / 1250 / 1600 / 2000 / 2500 / 3200 / 4000	
Rated ultimate breaking capacity (Icu)	1150V (kA)	30	50	
	1000V (kA)	42	65	
	900V (kA)	50	75	
	800V (kA)	50	75	

* AV series are applicable for IT system

Ampere Frame	AW-16C□		AW-20D□		AW-40E□	
	~ 1600AF		~ 2000AF		~ 4000AF	
Rated current (In) (A) at 40°C (A)	400 / 630 / 800 / 1000 / 1250 / 1600		200 / 400 / 630 / 800 / 1000 / 1250 / 1600 / 2000		400 / 630 / 800 / 1000 / 1250 / 1600 / 2000 / 2500 / 3200 / 4000	
Rated ultimate breaking capacity (Icu)	1150V (kA)	-	-		-	
	1000V (kA)	-	-		-	
	900V (kA)	-	42		50	
	800V (kA)	40	50		65	

* AW-08/16C are applicable for IT system

Contents

▪ Features	02
▪ Air Circuit Breakers	04
▪ Trip Unit	16
▪ Dimensions	20
▪ Technical information	44

Air Circuit Breakers

ACB ordering

AV	10	D	3	10	A
Type	Ampere Frame	Frame sizes & phase array	No. of poles	Rated current (CT SPEC.)	Connections
Circuit Breakers	06 630AF	D 630~2000AF 3P/4P Standard RST(N)	3 3-pole type (D)	00 Without OCR & CT	Draw-out type
AV	08 800AF	W 630~2000AF 4P Reverse phase type (N)RST	4 4-pole type (D, W)	02 200A	A Automatic connection
AW	10 1000AF			04 400A	Fixed type
	13 1250AF			06 630A	H Horizontal type
	16 1600AF			08 800A	V Vertical type
	20 2000AF			10 1000A	M Mixed type Horizontal Vertical
				13 1250A	N Mixed type Vertical Horizontal
				16 1600A	P Front type
				20 2000A	

* 2000AF only offers with vertical type mounting terminals(Busbar).

06 630AF	E 630~4000AF 3P/4P Standard RST(N)	3 3-pole type (E)	00 Without OCR & CT
08 800AF	X 630~4000AF 4P Reverse phase type (N)RST	4 4-pole type (E, X)	04 400A
10 1000AF			06 630A
13 1250AF			08 800A
16 1600AF			10 1000A
20 2000AF			13 1250A
25 2500AF			16 1600A
32 3200AF			20 2000A
40 4000AF			25 2500A
			32 3200A
			40 4000A

*4000AF only offers with vertical type mounting terminals(Busbar).

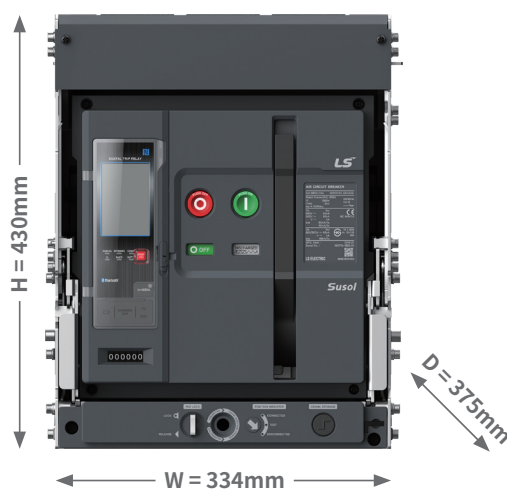

D-Frame ~ 2000AF
50kA @900VAC*
30kA @1150V



E-Frame ~ 4000AF
75kA @900VAC*
50kA @1150V

* DEKRA CB TBD.

M1		D1		D1		AX		SS1		U1		AL	
Motor power		Input power		Trip power		Auxiliary contact and charge method		STU		UVT			
MA	No motor	D0	No input coil	D0	No trip coil	AX	Standard type OFF - Charge 3a3b	Refer to page 7	U0	No UVT			
M1	AC/DC 100V~130V	D1	AC/DC 100V~130V	D1	AC/DC 100V~130V	AC	Standard type ON - Charge 3a3b		U1	AC/DC 100V~130V			
M2	AC/DC 200V~250V	D2	AC/DC 200V~250V	D2	AC/DC 200V~250V	BX	Standard type OFF - Charge 5a5b		U2	AC/DC 200V~250V			
M3	DC 125V	D3	DC 125V	D3	DC 125V	BC	Standard type ON - Charge 5a5b		U3	DC 125V			
M4	DC 24V~30V	D4	DC 24V~30V	D4	DC 24V~30V	HX	High capacity OFF - Charge 5a5b		U4	DC 24V~30V			
M5	DC 48V~60V	D5	DC 48V~60V	D5	DC 48V~60V	HC	High capacity ON - Charge 5a5b		U5	DC 48V~60V			
M6	AC 380V~415V	D6	AC 380V~480V	D6	AC 380V~480V	CC	Standard type ON - Charge 6a6b		U6	AC 380V~480V			
M7	AC 440V~480V	D7	AC 48V	D7	AC 48V	JC	High capacity ON - Charge 6a6b		U7	AC 48V			
M8	AC 48V					GX	High capacity OFF - Charge 3a3b						
						GC	High capacity ON - Charge 3a3b						
						TX	TCS OFF - Charge 4a4b						
						TC	TCS ON - Charge 5a5b						

* UVT Delay is composed from AC/DC 48V

Symbol	Option Model	Option description
AL	AL1 + MRB	
A1	AL1 + MRB + RES(AC 110~130V)	
A2	AL1 + AL2 + MRB	
A3	AL1 + MRB + RES(DC 110~125V)	
A4	AL1 + MRB + RES(AC 200~250V)	
A5	AL1 + MRB + AUTO RESET	
A6	AL1 + AL2 + MRB + AUTO RESET	
A7	AL1 + MRB + RES(DC 110~125V) + AUTO RESET *DC only	
A8	AL1 + MRB + RES(AC 200~250V) + AUTO RESET *AC only	
A9	AL1 + MRB + RES(AC 110~130V) + AUTO RESET *AC only	
Y2	AL1 + AL2 + MRB(2b contact)	
Y6	AL1 + AL2 + MRB + AUTO RESET(2b contact)	
Z2	AL1 + AL2 + MRB(1a1b contact)	
Z6	AL1 + AL2 + MRB + AUTO RESET(1a1b contact)	
C	C	Counter
S	CS2	Charge switch communication
B	B	On/Off Button lock
M	MI	Mechanical interlock)
D	DI or MOC	Door Interlock or MOC (Mechanism operated cell switch)
K	K1	Key Lock
K2	K2	Key Interlock Set
K3	K3	Key Lock Double
R	RCS	Ready to Close switch
T	TM	Temperature Monitoring
H1	SHT2	AC/DC 100~130V
H2	SHT2	AC/DC 200~250V
H3	SHT2	DC 125V
H4	SHT2	DC 24~30V
H1	SHT2	DC 48~60V
H6	SHT2	AC 380~480V
H7	SHT2	AC 48V

Note 1)

Note 1) Double shunt coil not applicable when using UVT

Air Circuit Breakers

ACB Cradle ordering

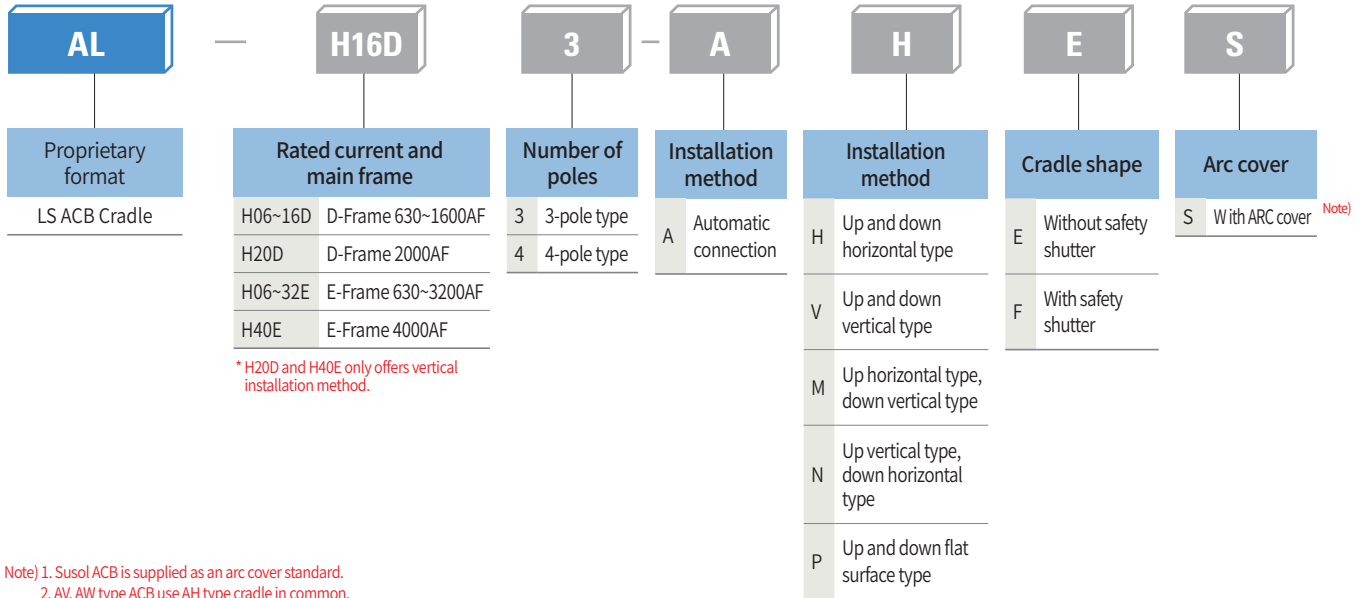

Smart Trip Unit ordering



N type

N		H		G	
Trip unit type		Communication & Leakage detection		Control power & Frequency	
O	N/A	O	N/A	O	N/A

N		H		G	
Trip unit type		Relay Function / Commutation Function(Default)		Frequency (Main Circuit) Control power voltage	
N	Normal	H	L,S,I,G + NFC	0	60Hz No control power
				5	50Hz No control power

* Self-power is Default
 * No Output Contact
 (Accident indication can be confirmed only by LED)



A type

A		G		0	
Trip unit type		Relay function / Commutation function		Frequency (Main Circuit) Control power voltage	
A	Ammeter	H	L,S,I,G	0	60Hz No control power
		D	L,S,I,G / Communication	1	60Hz AC/DC 110V~220V
		J	L,S,I,Gext + ZCT / Communication	2	60Hz DC 24V~48V TBD
		Y	L,S,I,Gext + Ground wire CT / Communication	5	50Hz No control power
		B	L,S,I + PTA / Communication	6	50Hz AC/DC 110V~220V
		O	L,S,I,G + Neutral CT / Communication	7	50Hz DC 24V~48V TBD
		V	L,S,I + PTA (For Marine)		

* Self-power is Default
 * Only AH Type can select "0,5"(AH0, AH5)
 * No Output Contact when choosing "0"
 (Accident indication can be confirmed only by LED)
 * AV Type has no LCD Screen



P type

P		S		1		
Trip unit type		Relay function / Commutation function(Default)		Frequency (Main Circuit) Control power voltage Communication		
P	Power meter	S	L,S,I,G + PTA	1	60Hz AC/DC 110V~220V	N/A
		J	L,S,I,Gext + ZCT	2	60Hz DC 24V~48V	N/A TBD
		Y	L,S,I,Gext + Ground wire CT	6	50Hz AC/DC 110V~220V	N/A
		O	L,S,I,G + Neutral CT	7	50Hz DC 24V~48V	N/A TBD
				3	60Hz AC/DC 110V~220V	Bluetooth
				4	60Hz DC 24V~48V	Bluetooth TBD
				8	50Hz AC/DC 110V~220V	Bluetooth
				9	50Hz DC 24V~48V	Bluetooth TBD



S type

S		S		1		
Trip unit type		Relay function / Commutation function(Default)		Frequency (Main Circuit) Control power voltage Communication		
S	Supreme meter	S	L,S,I,G + PTA	1	60Hz AC/DC 110V~220V	Bluetooth/NFC
		J	L,S,I,Gext + ZCT	2	60Hz DC 24V~48V	Bluetooth/NFC TBD
		Y	L,S,I,Gext + Ground wire CT	6	50Hz AC/DC 110V~220V	Bluetooth/NFC
		O	L,S,I,G + Neutral CT	7	50Hz DC 24V~48V	Bluetooth/NFC TBD

* Self-power is Default (Automatic power supply to the Trip Unit without additional control power)
 * L,S,I: Long time delay trip, Short time delay trip, Instantaneous trip
 * G: Ground fault (Residual earth fault protection)
 * Gext + ZCT: Earth leakage protection (Earth Fault Current: 0.5A ~ 30A) - Only suitable for under 1600A products and cables
 * Gext + Ground wire CT: Source return Type * PTA: Pre-trip alarm Function
 * Customers purchase their own Ground wire CT (Secondary output: 5A, accuracy 1%)
 * Customers purchase their own Neutral CT (Primary output: same as ACB's Rated Current / Secondary output: 5A, accuracy 1%)
 * The STU acceptable voltage range is 100 to 250V.
 * If you want an external VDM, please insert '(-V)' at the end of the full ordering.

Item	Description	Features	Remark
72313460708	TOTAL ASSY(VDM(Shield Cable), EXTERNAL, STU)	Accessory	Separate purchasing

* If you want to apply external VDM separately, please order the code above.

Air Circuit Breakers

Compact ACB ordering

AW	16	C	3	10	A
Air circuit breaker	Ampere frame (CT Spec.)	Frame sizes & phase array	Number of poles	Rated current	Installation & Connection
AW	08 800AF 16 1600AF	C Standard (N)RST V Reverse phase RST(N)	3 3P(C) 4 4P(C,V)	00 None 04 400A 06 630A 08 800A 10 1000A 13 1250A 16 1600A	withdrawable type A Automatic connection Fixed type H Horizontal type V Vertical type M Upper-Horizontal /Lower-Vertical type N Upper-Vertical/ Lower-Horizontal type P Flat type Z** Flat spread type R*** Spread type T** Flat vertical type X** Cable lug type

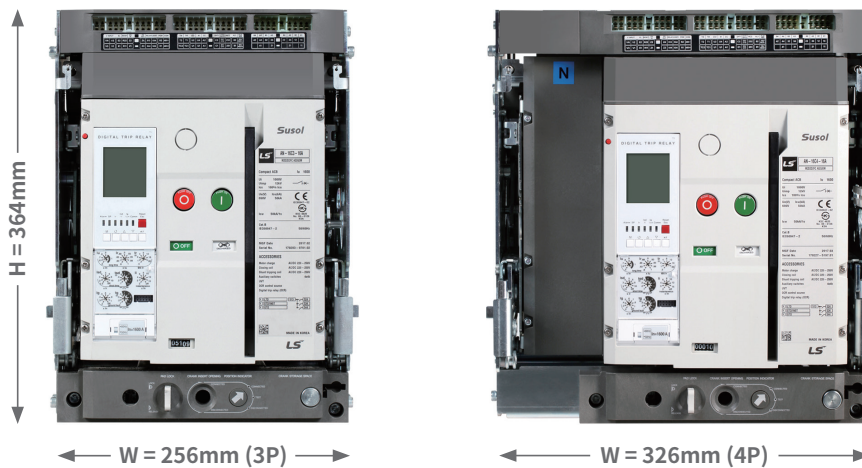

* Installation method is common to all models

** When using Z, T and X type, please purchase adaptor kit separately after ordering P type product (Refer to fixed adaptor kit table)

*** When using R type, purchase purchase adaptor kit separately after ordering H type product (Refer to fixed adaptor kit table)

1. Fixed type Adaptor Kit

Number	Part Name	Product Name	How to install	Pole
62363471509	Terminal Kit Ass'y	SUB ASSY,ADAPTER KIT ASS'Y_SPREAD_FIXED,AN,AH,AR-C3	Z	3
62363471510		SUB ASSY,ADAPTER KIT ASS'Y_SPREAD_FIXED,AN,AH,AR-C4	Z	4
62363471511		SUB ASSY,ADAPTER KIT ASS'Y_SPREAD/VER_FIXED,AN,AH,AR-C3	T	3
62363471512		SUB ASSY,ADAPTER KIT ASS'Y_SPREAD/VER_FIXED,AN,AH,AR-C4	T	4
62363471513		SUB ASSY,ADAPTER KIT ASS'Y_LUG_FIXED,AN,AH,AR-C3	X	3
62363471514		SUB ASSY,ADAPTER KIT ASS'Y_LUG_FIXED,AN,AH,AR-C4	X	4
62363471515		SUB ASSY,ADAPTER KIT ASS'Y_SPREAD,AN,AH-C3	R	3
62363471516		SUB ASSY,ADAPTER KIT ASS'Y_SPREAD,AN,AH-C4	R	4

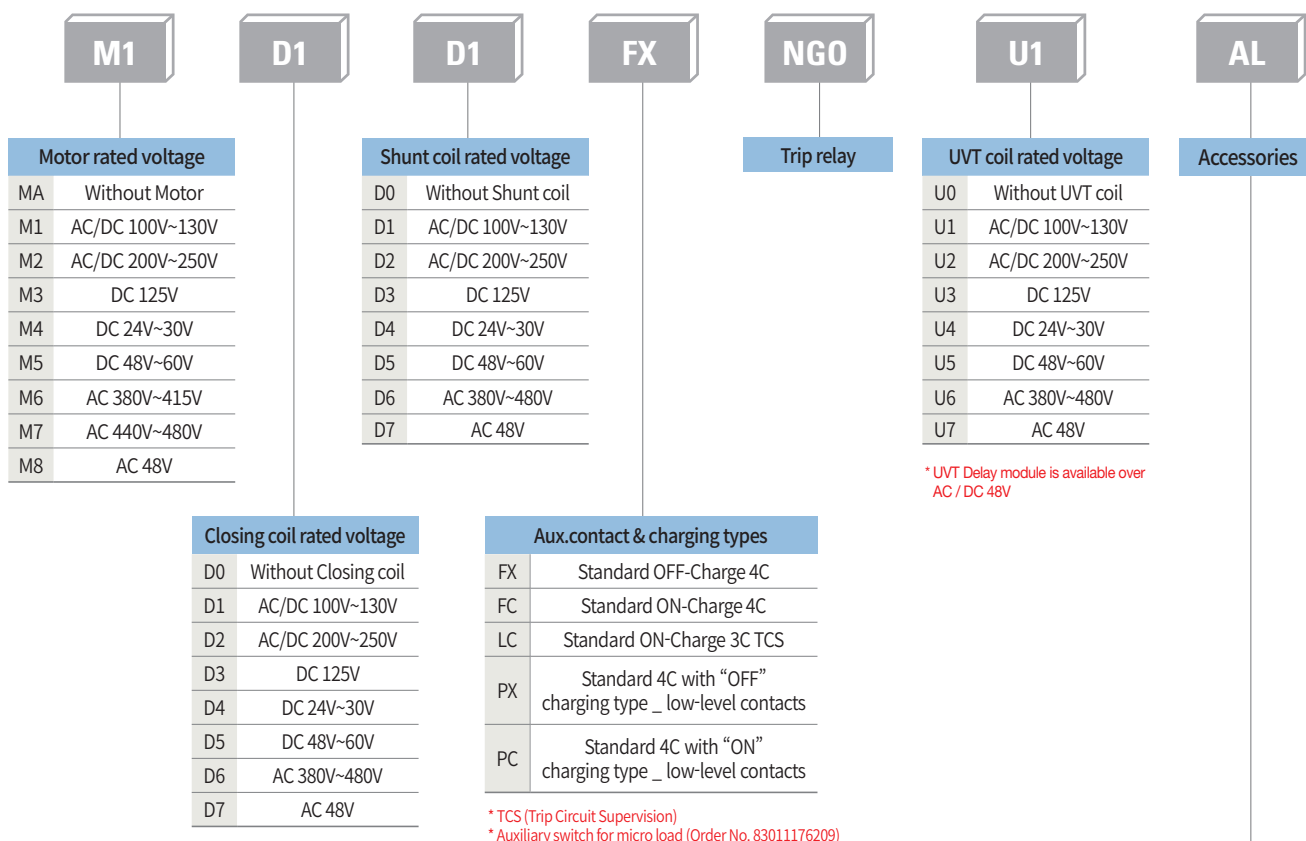

E01	A4 (AL1 + MRB + RES(AC200~250V))+C(Counter)+B(ON/OFF Button Lock)+K(Key Lock)+R(Ready to close switch)+M(Mechanical Interlock)
E02	AL (AL1 + MRB)+K(Key Lock(OFF Lock))+R(Ready to close switch)+D(Door Interlock or MOC)+H1(AC/DC 100V ~ 130V, Double Shunt Coil)
E03	C(Counter)+B(ON/OFF Button Lock)+K2(Key Interlock Set)+R(Ready to close switch)
E04	A4(AL1 + MRB + RES(AC200~250V))+B(ON/OFF Button Lock)+K(Key Lock(OFF Lock))+M(Mechanical Interlock)
E05	A1(AL1+MRB+RES110~130V)+B(ON/OFF Button Lock)+K(Key Lock(OFF Lock))+R(Ready to close switch)+M(Mechanical Interlock)
E06	A2(AL1+AL2+MRB)+C(Counter)+K(Key Lock(OFF Lock))+R(Ready to close switch)

Code	Description	Option description
AL	AL1 + MRB	
A1	AL1 + MRB + RES(AC110~130V)	*AC Only
A2	AL1 + AL2 + MRB	
A3	AL1 + MRB + RES(DC 110~125V)	*DC Only
A4	AL1 + MRB + RES(AC 200~250V)	*AC Only
A5	AL1 + MRB + Auto Reset	
A6	AL1 + AL2 + MRB + Auto Reset	
A7	AL1 + MRB + RES(DC 110~125V) + Auto Reset	*DC Only
A8	AL1 + MRB + RES(AC 200~250V) + Auto Reset	*AC Only
A9	AL1 + MRB + RES(AC 110~130V) + Auto Reset	*AC Only
C	C	Counter
B	B	On/Off Button lock
M	MI	Mechanical interlock
D	DI or MOC	Door Interlock or MOC (Mechanism operated cell switch)
K	K1	Key Lock
K2	K2	Key Interlock Set
R	RCS	Ready to Close switch
H1	SHT2 ^{Note 2)}	AC/DC 100~130V, Double Shunt coil
H2		AC/DC 200~250V, Double Shunt coil
H3		DC 125V, Double Shunt coil
H4		DC 24~30V, Double Shunt coil
H5		DC 48~60V, Double Shunt coil
H6		AC 380~480V, Double Shunt coil
H7		AC 48V, Double Shunt coil

Note 1) * If mixed option is more than 5, it is separated by mixed option code.
 2) UVT & SHT2 can be not applicable together.

Air Circuit Breakers

ACB Cradle ordering

AL	H16C	3	A	H	E	S
Air circuit breaker	Type & Ampere frame	Number of poles	Secondary connection type	Installation & Connection		Arc cover
LS ACB Cradle AL Bottom operating cradle	H16C 400~1600A	3 3P 4 4P	A Auto connection	H Horizontal type V Vertical type M Upper-Horizontal / Lower-Vertical type N Upper-Vertical / Lower-Horizontal type P** Flat type Z** Flat spread type R*** Spread type T** Flat vertical type X** Cable lug type	S with arc cover Shutter E without shutter F with shutter	

Note) AV, AW type ACB use AH type cradle in common.

** When using P, Z, T and X type, please purchase adapter kit separately after ordering P type product (Refer to fixed adapter kit table)

*** When using R type, purchase purchase adapter kit separately after ordering H type product (Refer to fixed adapter kit table)

2. Draw-out type Adaptor Kit (Cradle)

Number	Part Name	Product Name	How to install	Pole
62363471501	Terminal Kit Ass'y	SUB ASS'Y,ADAPTER KIT ASS'Y_FRONT,AN,AH-C3	P	3
62363471502		SUB ASS'Y,ADAPTER KIT ASS'Y_FRONT,AN,AH-C4	P	4
62363471503		SUB ASS'Y,ADAPTER KIT ASS'Y_FRONT_SPREAD,AN,AH-C3	Z	3
62363471504		SUB ASS'Y,ADAPTER KIT ASS'Y_FRONT_SPREAD,AN,AH-C4	Z	4
62363471505		SUB ASS'Y,ADAPTER KIT ASS'Y_SPREAD/VER,AN,AH-C3	T	3
62363471506		SUB ASS'Y,ADAPTER KIT ASS'Y_SPREAD/VER,AN,AH-C4	T	4
62363471507		SUB ASS'Y,ADAPTER KIT ASS'Y_LUG,AN,AH-C3	X	3
62363471508		SUB ASS'Y,ADAPTER KIT ASS'Y_LUG,AN,AH-C4	X	4

Various installation methods

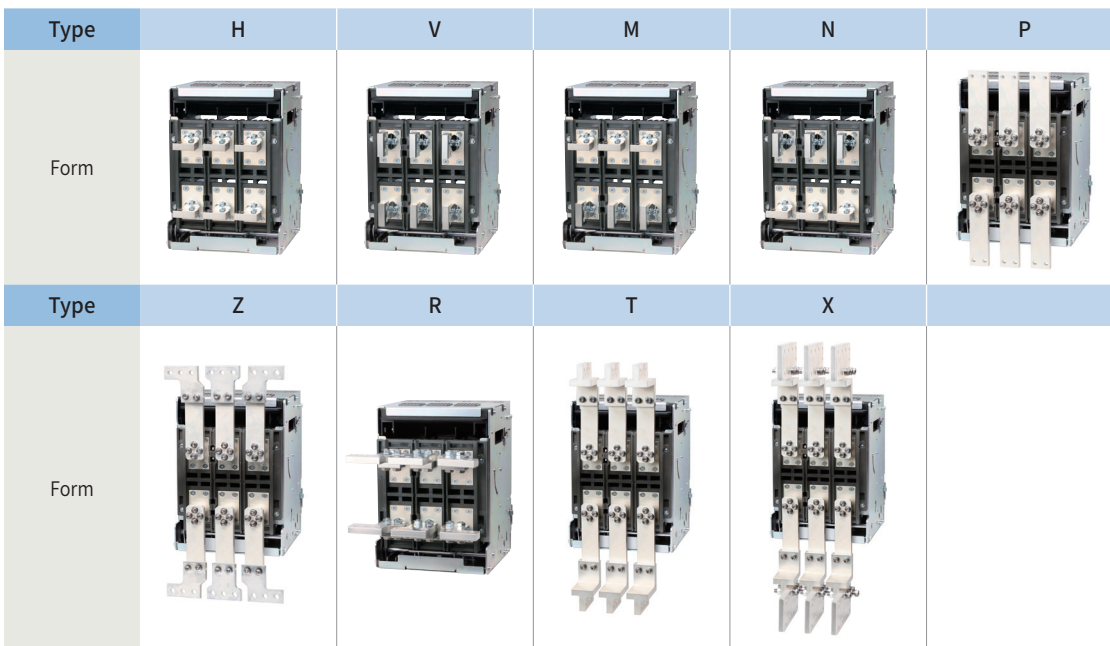

Compact ACB Trip unit ordering



N		G		0			
Trip relay type		Communication & protection				Control voltage & frequency	
N		G				0	
0	Without trip relay	G	Ground fault			0	Self-Power ^{Note1)} 60Hz
N	Normal	* L/S/I/G configuration as standard - with LED indicators - without output contacts * Ground fault system by vector sum					
A		G				0	
A	Ammeter	G	Ground fault			0	Self-Power 60Hz
		Z	Earth Leakage(External CT, Earth Leakage below 30A)			1	AC/DC 100V~250V 60Hz
		E	Earth Leakage(External CT, Earth Leakage over 30A)			2	DC 15V~60V 60Hz
		C	Ground fault + Comm.			5	Self-Power 50Hz
		K	Earth Leakage(External CT, Earth Leakage below 30A) + Comm.			6	AC/DC 100V~250V 50Hz
		X	Earth Leakage(External CT, Earth Leakage over 30A) + Comm.			7	DC 15V~60V 50Hz
		N**	Ground fault (External NCT) + Comm.				
		* L/S/I/G(or EL) configuration as standard (Only. Unable to select ground fault and earth leakage, simultaneously) * Ground fault system by vector sum(G,C) * Earth leakage system - Z,K: External CT - LS ZCT applied(fault current 0.5~30A, 1600AF) - E,X: External CT - Private ZCT applied(fault current >30A, 2000AF) * Comm. And output contacts DO NOT work under self-power condition.(Only checking LED available)					
P		C				1	
P	Power meter	C	Ground fault + Comm.			1	AC/DC 100V~250V 60Hz
		K	Earth Leakage(External CT, Earth Leakage below 30A) + Comm.			2	DC 15V~60V 60Hz
		X	Earth Leakage(External CT, Earth Leakage over 30A) + Comm.			6	AC/DC 100V~250V 50Hz
		A	Pre-Trip Alarm + Comm.			7	DC 15V~60V 50Hz
		N**	Ground fault (External NCT) + Comm.				
		* L/S/I/G(or EL) configuration as standard (Only. Unable to select ground fault and earth leakage, simultaneously) * Ground fault system by vector sum * Earth leakage system - K: External CT - LS ZCT applied(fault current 0.5~30A, 1600AF) - X: External CT - Private ZCT applied(fault current >30A, 2000AF) * Applicable to generator protection purpose * Comm. And output contacts DO NOT work under self-power condition.(Only checking LED available)					
S		C				1	
S	Supreme meter	C	Ground fault + Comm.			1	AC/DC 100V~250V 60Hz
		K	Earth Leakage(External CT, Earth Leakage below 30A) + Comm.			2	DC 15V~60V 60Hz
		X	Earth Leakage(External CT, Earth Leakage over 30A) + Comm.			6	AC/DC 100V~250V 50Hz
		A	Pre-Trip Alarm + Comm.			7	DC 15V~60V 50Hz
		N**	Ground fault (External NCT) + Comm.				
		* L/S/I/G(or EL) configuration as standard (Only. Unable to select ground fault and earth leakage, simultaneously) * Ground fault system by vector sum * Earth leakage system - K: External CT - LS ZCT applied(fault current 0.5~30A, 1600AF) - X: External CT - Private ZCT applied(fault current >30A, 2000AF) * Applicable to generator protection purpose * Comm. And output contacts DO NOT work under self-power condition.(Only checking LED available)					

** AN, PN, SN provide the function to detect and protect the ground fault current by applying the NCT (Neutral CT) in the neutral wire when 3pole circuit breaker is used in 3-phase 4-wire system. Please use NCT with the secondary output of 5A rating. (NCT is not provided)

Note) 1. L/S/I/G(or EL) configuration as standard (Only. Unable to select ground fault and earth leakage, simultaneously)
2. Ground fault, earth leakage and pre-trip alarm functions are alternative.
3. The functions like Metering, Communication, ZSI, Remote reset and Digital output are NOT available only under Self-power condition.
4. Voltage module should be required for P and S types purchased separately

Air Circuit Breakers

Susol ACB up to 1150Vac

Characteristics							
Number of poles	(P)		3 / 4				
Rated operational voltage (Ue)	(Vac)		~ 1150				
Rated insulation voltage (Ui)	(V)		1250				
Rated impulse withstand voltage (Uimp)	(kV)		12kV				
Version			Fixed / Withdrawable				
Suitability for isolation							
Degree of pollution	IEC60661-1		3				
Certification			CB certification according to IEC 60947-2				
Brand name		Susol AV					
Model		AV-06D	AV-08D	AV-10D	AV-13D	AV-16D	AV-20D
Ampere Frame	(AF)	630	800	1000	1250	1600	2000
Rated current (In max)	(A)	200	400	630	630	800	1000
		400	630	800	800	1000	1250
		630	800	1000	1000	1250	1600
Rated ultimate breaking capacity (Icu)	1150V	(kA)			30		
	1000V	(kA)			42		
	900V	(kA)			50		
	800V	(kA)			50		
Rated service breaking capacity (Ics)	(% Icu)			100			
Rated short- timewithstand current (Icw)	1s	(kA)		30			
	3s	(kA)		30			
Rated making capacity (Icm)	(kA)			63			
Selectivity category (according to IEC 60947-2)				B			
Operation time (ms)	Total Breaking time	< Icw		max. 75			
		≥ Icw		max. 25			
	Closing time			max. 80			
Mechanical and Electrical Life cycle							
Endurance (times) (Without maintenance)	Mechanical			12,500			
	Electrical			1,000			
Dimension and Weight							
Weight (3P/4P)	Draw-out	Without cradle	(kg)	37/45			
		With cradle	(kg)	70/85			
	Fixed	(kg)	34/44				
External Dimensions (H×W×D)	Draw-out	3P(4P)	(mm)	430×334(419)×375			
	Fixed	3P(4P)	(mm)	300×300(385)×295			

* AV series are applicable for IT system

Air Circuit Breakers

Susol ACB up to 900Vac

Characteristics																	
Number of poles	(P)	3 / 4															
Rated operational voltage (Ue)	(Vac)	~ 900															
Rated insulation voltage (Ui)	(V)	1000															
Rated impulse withstand voltage (Uimp)	(kV)	12kV															
Version		Fixed / Withdrawable															
Suitability for isolation																	
Degree of pollution	IEC60661-1	3															
Certification		CB certification according to IEC 60947-2															
Brand name		Susol AW															
Model		AW-06D	AW-08D	AW-10D	AW-13D	AW-16D	AW-20D	AW-06E	AW-08E	AW-10E	AW-13E	AW-16E	AW-20E	AW-25E	AW-32E	AW-40E	
Ampere Frame	(AF)	630	800	1000	1250	1600	2000	630	800	1000	1250	1600	2000	2500	3200	4000	
Rated current (In max)	(A)	200	400	630	630	800	1000	400	400	630	630	800	1000	1250	1600	2000	
		400	630	800	800	1000	1250	630	630	800	800	1000	1250	1600	2000	2500	
		630	800	1000	1000	1250	1600	2000	800	1000	1000	1250	1600	2000	2500	3200	
Rated ultimate breaking capacity (Icu)	900V	42						50									
	800V	50						65									
Rated service breaking capacity (Ics)	(% Icu)	100															
Rated short-time withstand current (Icw)	1s	42						50									
	3s	42						50									
Rated making capacity (Icm)	(kA)	88.2						105									
Selectivity category (according to IEC 60947-2)		B															
Operation time (ms)	Total Breaking time	< Icw		max. 75													
		≥ Icw		max. 25													
	Closing time		max. 80														
Mechanical and Electrical Life cycle																	
Endurance (times) (Without maintenance)	Mechanical	20,000						10,000									
	Electrical	1,000															
Dimension and Weight																	
Weight (3P/4P)	Draw-out	Without cradle	(kg)		37/45						44/49						
		With cradle	(kg)		70/85						88/104						
	Fixed	(kg)		34/44						45/56							
External Dimensions (H×W×D)	Draw-out	3P(4P)	(mm)		430×334(419)×375						430×412(527)×375						
	Fixed	3P(4P)	(mm)		300×300(385)×295						300×378(493)×295						

Susol Compact ACB up to 800Vac

Characteristics			
Number of poles	(P)		3 / 4
Rated operational voltage (Ue)	(Vac)		~ 800
Rated insulation voltage (Ui)	(V)		1000
Rated impulse withstand voltage (Uimp)	(kV)		12kV
Version			Fixed / Withdrawable
Suitability for isolation			
Degree of pollution	IEC60661-1		3
Certification			CB certification according to IEC 60947-2
Brand name		Susol AW	
Model		AW-08C	AW-16C
Ampere Frame	(AF)	800	1600
Rated current (In max)	(A)	400 630 800	800 1000 1250 1600
Rated ultimate breaking capacity (Icu)	800V (kA)		40
Rated service breaking capacity (Ics)	(% Icu)		100
Rated short-time withstand current (Icw)	1s (kA)		40
	3s (kA)		40
Rated making capacity (Icm)	(%)		84
Selectivity category (according to IEC 60947-2)			B
Operation time (ms)	Total Breaking time	< Icw	max. 75
		≥ Icw	max. 25
	Closing time		max. 80
Mechanical and Electrical Life cycle			
Endurance (times) (Without maintenance)	Mechanical		12,500
	Electrical		500
Dimension and Weight			
Weight	Draw-out (3P/4P)	(kg)	22/26
	Fixed (3P/4P)	(kg)	16/19.5
External Dimensions (H×W×D)	Draw-out	3P (mm)	W: 256 D: 274.5 ¹⁾ H: 364.3
		4P (mm)	W: 326 D: 274.5 ¹⁾ H: 364.3
	Fixed	3P (mm)	W: 272.4 D: 198.5 ¹⁾ H: 322
		4P (mm)	W: 342.4 D: 198.5 ¹⁾ H: 322

1) Exclude terminal length

* AW-08/16C are applicable for IT system

Smart Trip Unit

Advanced trip relay!

With the world's best measurement accuracy and increased relay elements, the relay operation stability is enhanced, and the self-diagnosis function prevents mis-trips and ensures the stability of abnormal conditions through alarms.

NFC and Bluetooth built-in and Smart add-on modules can be configured. Monitoring and monitoring is possible through service access anytime, anywhere by securing a Smart LV solution through ICT convergence technology.

*STU is for D, E Frame

STU series for function



N type

- Device operation through self-power
- Current relay function
- **Supports USB communication**
- Available NFC communication



A type

- Device operation through self-power
- Current relay function
- Segment LCD Display
- DO output
- **Supports USB communication**
- Supports RS485 communication



P type

- Device operation through self-power
- Current/voltage/frequency/power relay function
- **3.5" touch screen**
- DO output
- **Supports USB communication**
- Supports RS485 communication
- Available BLE communication



S type

- Device operation through self-power
- Current/voltage/frequency/power relay function
- **3.5" touch screen**
- DO output
- Relay setting group A/B available
- Supports USB communication
- Supports RS485 communication
- **NFC/BLE communication support**



Types of STU

	Type N	Type A	Type P	Type S
Exterior				
Current relay	• L (N), S, I, G	• L (N), S, I, G, PTA, Gext	• L (N), S, I, G, PTA, Gext • D, S (V), IU	• L (N), S1, S2, I, G, PTA, Gext • D, S (V) 1, S (V) 2
Voltage relay	-	-	• UV, OV, RV, VU	• UV1, UV2, OV1, OV2, RV, VU
Frequency relay	-	-	• UF, OF, ROCOF	• UF1, UF2, OF1, OF2, ROCOF
Power relay	-	-	• RP, RQ, OP, OQ, UP	• RP, RQ1, RQ2, OP, OQ, UP
Group control	-	-	-	• A, B (can be changed by communication)
Relay fine adjustment	-	-	• L, S, I Pickup current	-
ERMS	-	• Control by DI and communication	• Control by DI and communication	• Control by DI and communication
IDMTL support	• Supports L relay element Thermal and DT, SIT, VIT, EIT, EIT5	• Supports L relay element Thermal and DT, SIT, VIT, EIT, EIT5	• Supports L relay element Thermal and DT, SIT, VIT, EIT, EIT5	• Supports L relay element Thermal and DT, SIT, VIT, EIT, EIT5
Trip information maintenance LED	• L, S, I, G/SP	• L, S, I, G/Gext/PTA, SP	• L, S, I, G/Gext/PTA, SP	• L, S, I, G/Gext/PTA, SP
Accident record	Screen	-	• 127 accident events indicated [Accident phase/current/time]	• 127 accident events indicated [Accident phase/current/time]
	Memory	• 127 accident events indicated [Accident phase/current/time]	• 127 accident events indicated • 6 accident events indicated [Does not support Selfpower]	• 127 accident events indicated • 6 accident events indicated [Does not support Selfpower]

Note) SP : Self-Protection trip function

Compact Trip Unit

The trip relay of Compact ACB provides the additional protection functions for voltage, frequency, unbalance, and others in addition to main protection functions for over current, short-circuit, ground fault. It supports the advanced measurement functions for voltage, current, power, electric energy, harmonics, communication function, and others.





Analog trip function interlocked with mechanism enhanced a durability of devices as well as the breaking capacity of ACB.

Zone selective interlocking function makes the protective coordination more simple and thermal memory can be applied to various loads.

*OCR is for C Frame



Trip relay types

Classification	N type	A type	P type	S type
Externals				
Current protection	• L/S/I/G/Thermal	• L/S/I/G/Thermal • ZSI (Protective coordination)	• L/S/I/G • ZSI (Protective coordination) • Thermal (Linear Hot Start)	• L/S/I/G • ZSI (Protective coordination) • Thermal (Linear Hot Start)
Other protection	-	• Earth leakage (Option)	• Earth leakage (Option) • Over/Under voltage • Over/Under frequency • Unbalance (Voltage/Current) • Reverse power	• Earth leakage (Option) • Over/Under voltage • Over/Under frequency • Unbalance (Voltage/Current) • Reverse power
Measurement function	-	• Current (R/S/T/N)	• 3 Phase Voltage/Current RMS/Vector • Power (P, Q, S), PF (3-Phase) • Energy (Positive/Negative) • Frequency, Demand	• 3 Phase Voltage/Current RMS/Vector • Power (P, Q, S), PF (3-Phase) • Energy (Positive/Negative) • Frequency, Demand • Voltage/Current harmonics (1st~63th) • 3 Phase Waveforms • THD, TDD, K-Factor
Fine adjustment	-	-	• Fine adjustment for long/short time delay/instantaneous/ ground	• Fine adjustment for long/short time delay/instantaneous/ ground
Digital Output	-	• 3DO (Fixed) • L, S/I, G Alarm	• 3DO (Programmable) • Trip, Alarm, General	• 3DO (Programmable) • Trip, Alarm, General
IDMTL setting	-	-	• Compliance with IEC60255-3: SIT, VIT, EIT, DT	• Compliance with IEC60255-3: SIT, VIT, EIT, DT
Communication	-	• Modbus/RS-485 • Profibus-DP	• Modbus/RS-485 • Profibus-DP	• Modbus/RS-485 • Profibus-DP
Power supply	• Self Power – Power source workover 20% of load current.	• Self Power – Power source workover 20% of load current. – External power source are required for comm. • AC/DC 100~250V • DC 24~60V	• AC/DC 100~250V • DC 24~60V • Basic protection function (L/S/I/G) is still under normal operation without control power.	• AC/DC 100~250V • DC 24~60V • Basic protection function (L/S/I/G) is still under normal operation without control power.
RTC Timer	• Available	• Available	• Available	• Available
LED for trip info.	• Long time delay • Short time delay/Instantaneous • Ground fault	• Long time delay • Short time delay/Instantaneous • Ground fault	• Long time delay • Short time delay/Instantaneous • Ground fault	• Long time delay • Short time delay/Instantaneous • Ground fault
Fault recording	-	• 10 records (Fault/Current/Date and Time)	• 256 records	• 256 records • Last fault wave form recording (3 Phase)
Event recording	-	-	• 256 records (Content, Status, Date)	• 256 records (Content, Status, Date)
Operating button	• Reset button	• Reset, Menu Up/Down, Left/Right, Enter	• Reset, Menu Up/Down, Left/Right, Enter	• Reset, Menu Up/Down, Left/Right, Enter

Each OCR type has Battery in itself.

1. Battery lifespan

- 1) When turned off: 14~28years
- 2) When using 1 LED consecutively or turned off: 7~14days

2. The recognizable range of OCR current

- 1) 1 ϕ : When more 20% than rated current(In) (ratio to In regardless of Iu and Ir)
- 2) 3 ϕ : When more 12% than rated current(In)

Dimensions

800/1600AF (400~1600A : AW-08/16C)

• 3P [Fixed H: Horizontal type / V: Vertical type]

(Unit : mm)

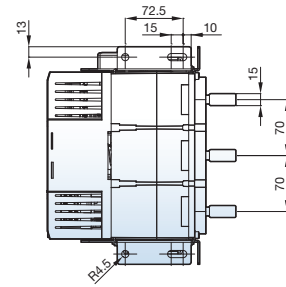
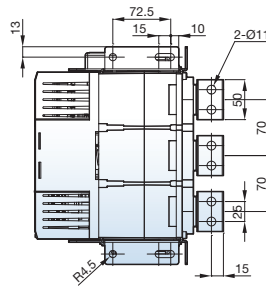
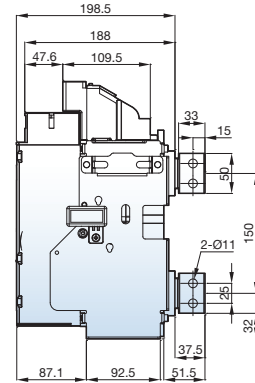
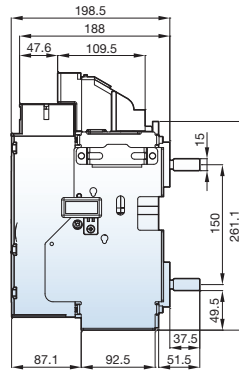
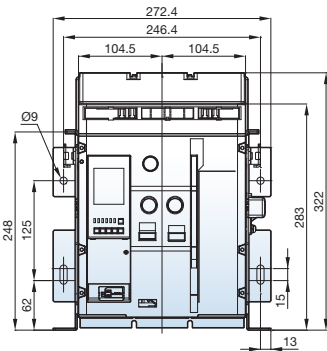

H Type (Horizontal type)

V Type (Vertical type)

• 3P [Fixed M: Upper-Horizontal type, Lower-Vertical type / N: Upper-Vertical type, Lower-Horizontal type]

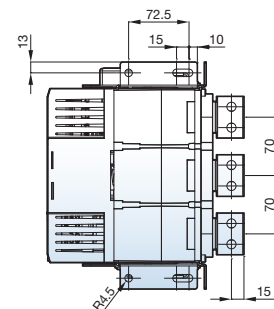
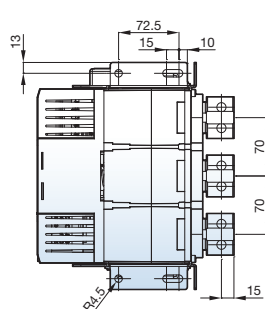
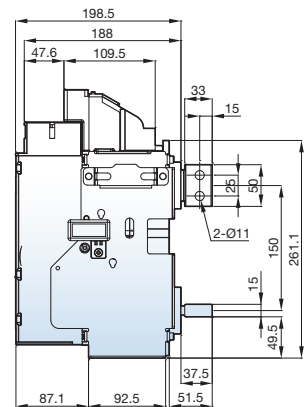
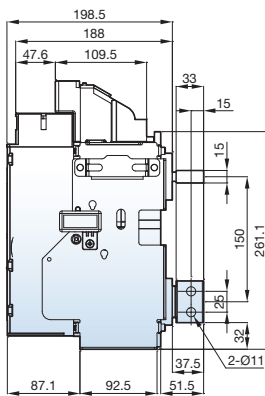
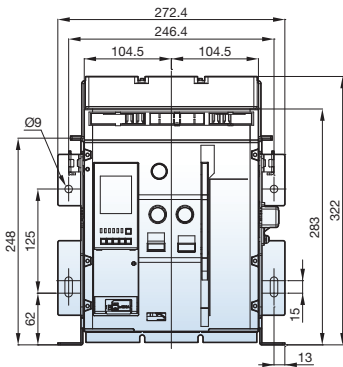

M Type

(Upper-Horizontal type, Lower-Vertical type)

N Type

(Upper-Vertical type, Lower-Horizontal type)

800/1600AF (400~1600A : AW-08/16C)

• 3P [Fixed P: Plane type / R: Spread type]

(Unit : mm)

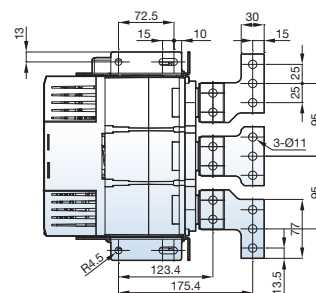
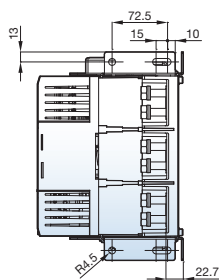
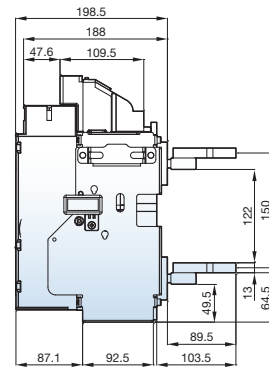
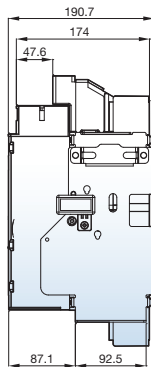
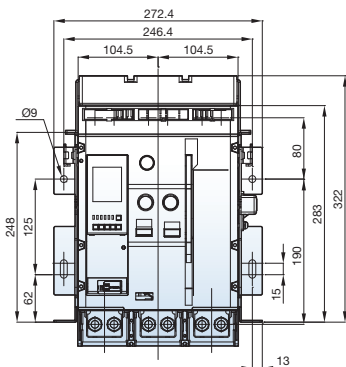

P Type (Plane type)

R Type (Spread type)

• 3P [Fixed Z: Plane spread type / T: Plane vertical type]

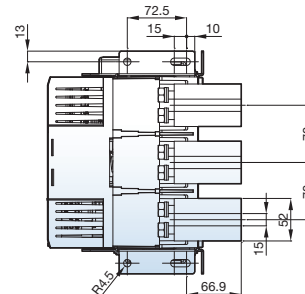
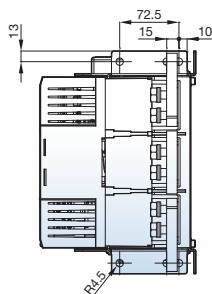
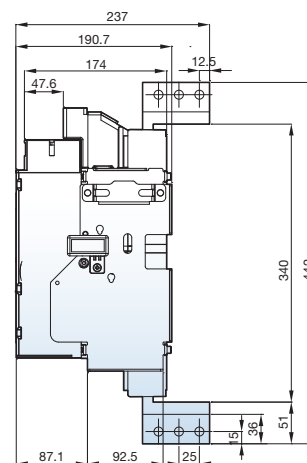
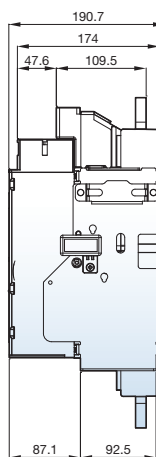
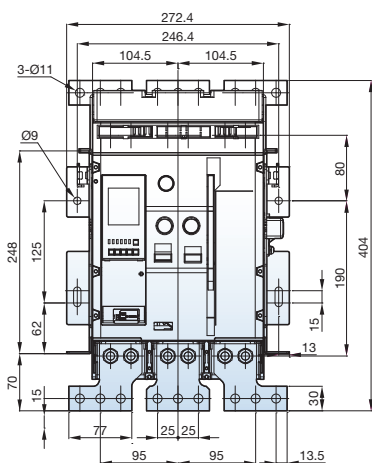

Z Type (Plane spread type)

T Type (Plane vertical type)

Dimensions

800/1600AF (400~1600A : AW-08/16C)

• 3P [Fixed X: Cable lug type]

(Unit : mm)

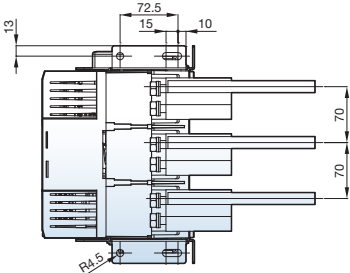
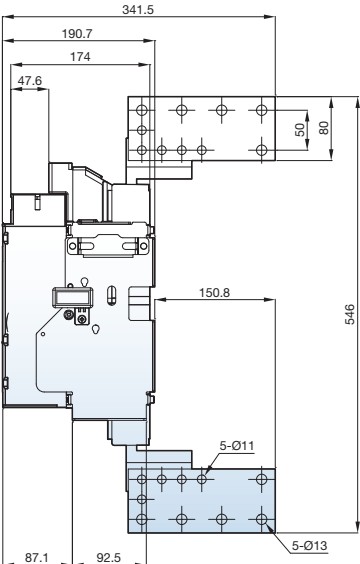
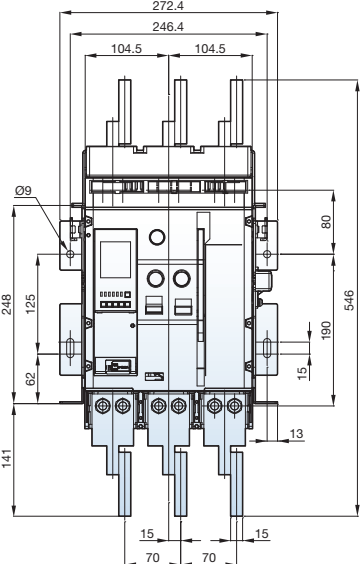

X Type (Cable lug type)

800/1600AF (400~1600A : AW-08/16C)

• 4P [Fixed H: Horizontal type / V: Vertical type]

(Unit : mm)

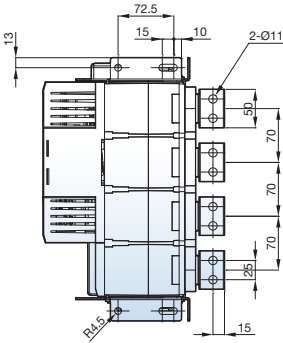
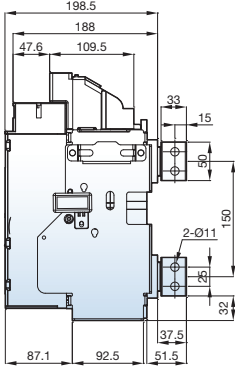
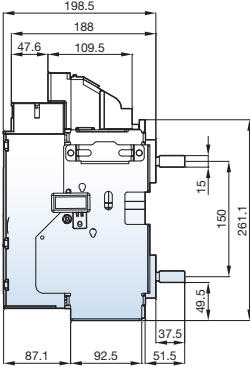
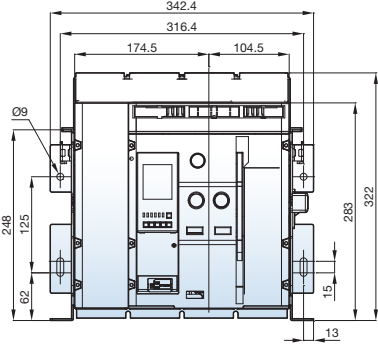

H Type (Horizontal type)

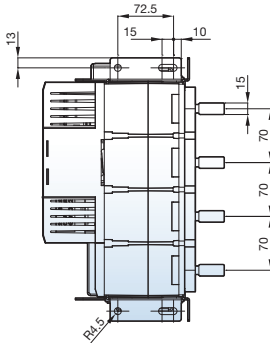

V Type (Vertical type)

• 4P [Fixed M: Upper-Horizontal type, Lower-Vertical type / N: Upper-Vertical type, Lower-Horizontal type]

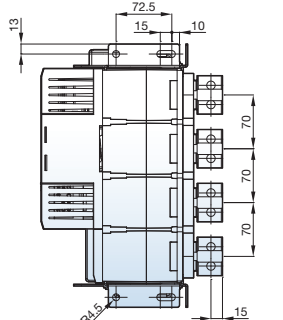
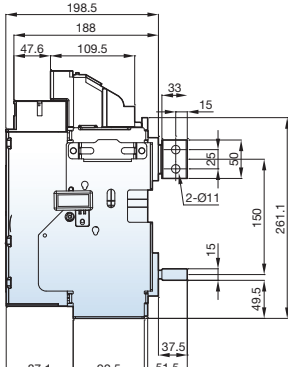
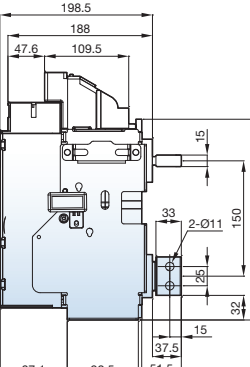
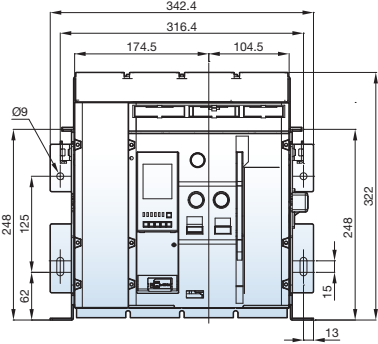

M Type
(Upper-Horizontal type, Lower-Vertical type)

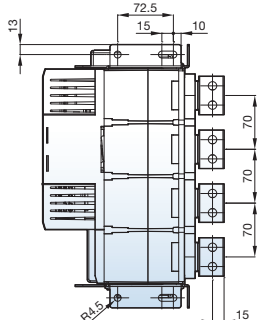

N Type
(Upper-Vertical type, Lower-Horizontal type)

Dimensions

800/1600AF (400~1600A : AW-08/16C)

• 4P [Fixed P: Plane type / R: Spread type]

(Unit : mm)

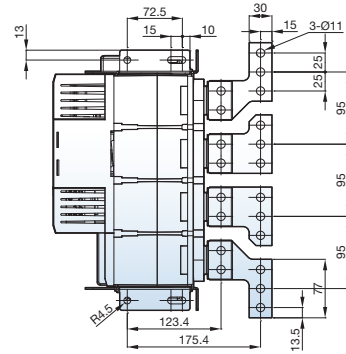
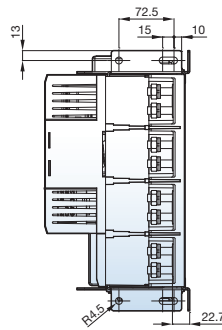
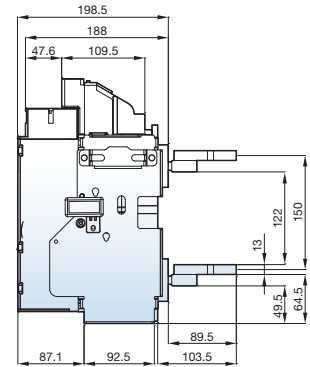
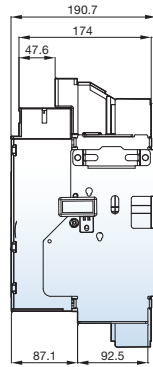
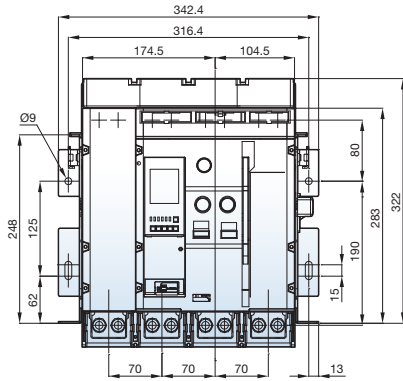

P Type (Plane type)

R Type (Spread type)

• 4P [Fixed Z: Plane spread type / T: Plane vertical type]

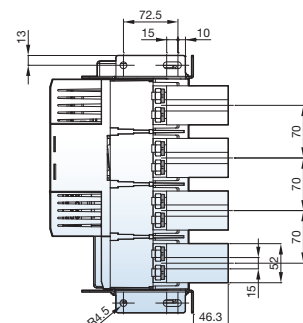
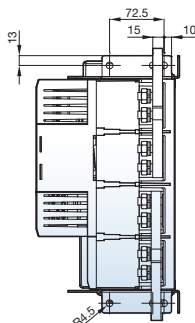
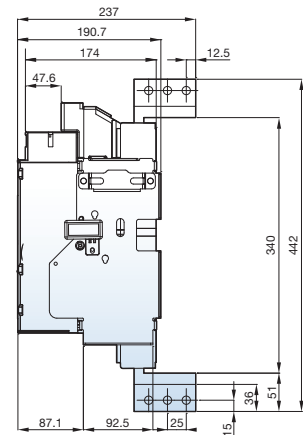
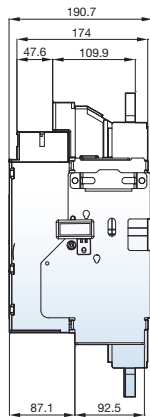
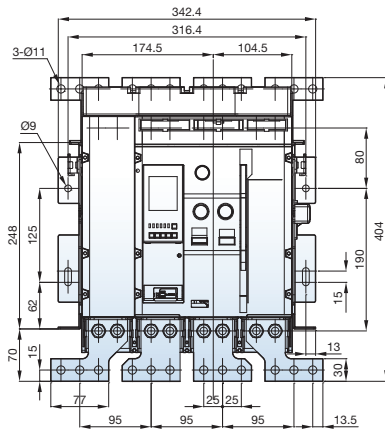

Z Type (Plane spread type)

T Type (Plane vertical type)

800/1600AF (400~1600A : AW-08/16C)

• 4P [Fixed X: Cable lug type]

(Unit : mm)

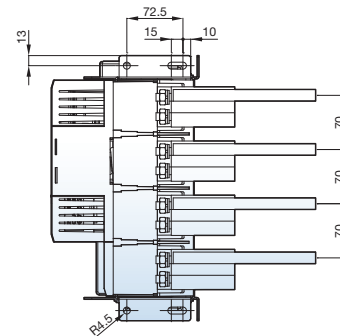
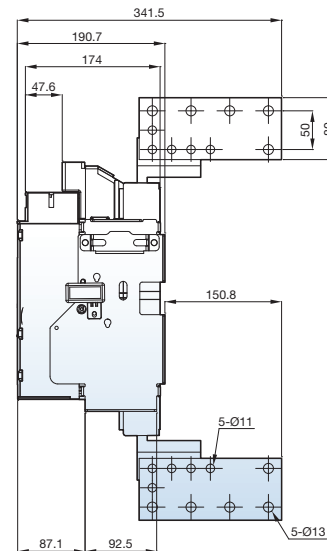
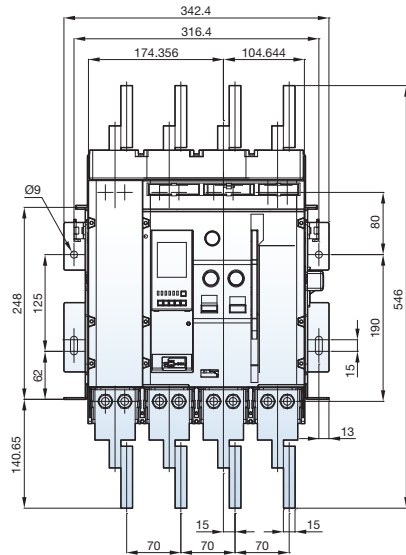

X Type (Cable lug type)

Fixed Door Frame: DF

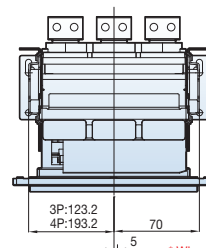

* When the hinge of the switchboard door is on the left side of the front

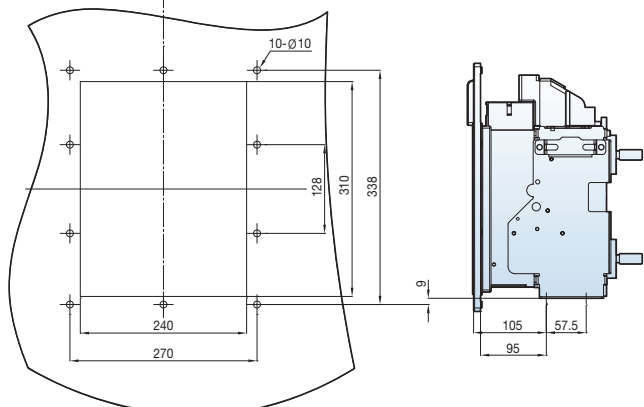
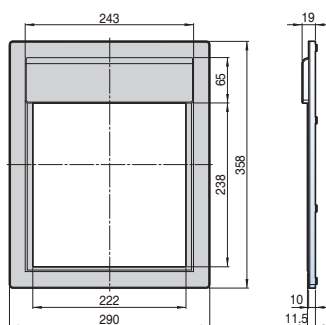

Dimensions

800/1600AF (400~1600A : AW-08/16C)

• 3P [Draw-out H: Horizontal type / V: Vertical type]

(Unit : mm)

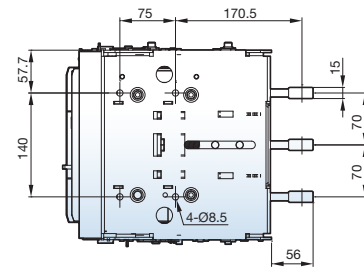
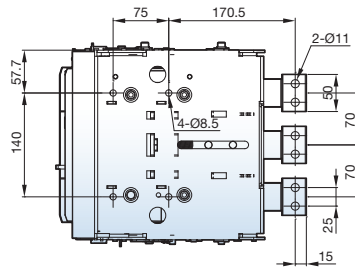
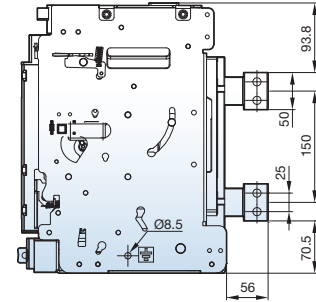
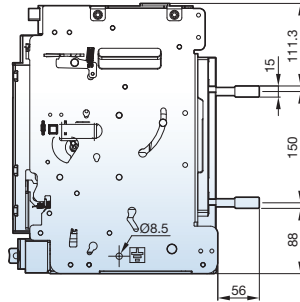
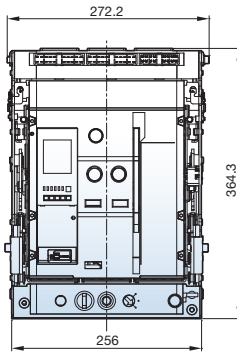

H Type (Horizontal type)

V Type (Vertical type)

• 3P [Draw-out M: Upper-Horizontal type, Lower-Vertical type / N: Upper-Vertical type, Lower-Horizontal type]

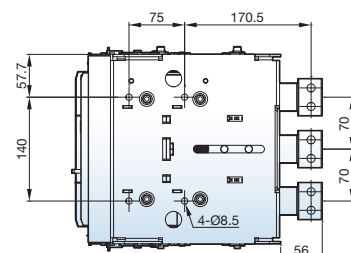
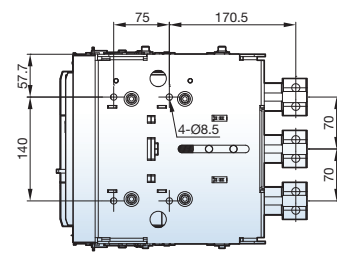
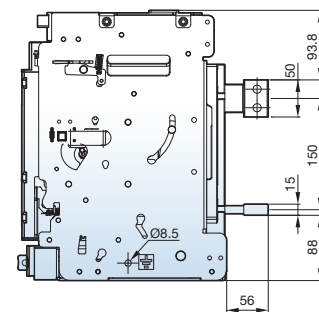
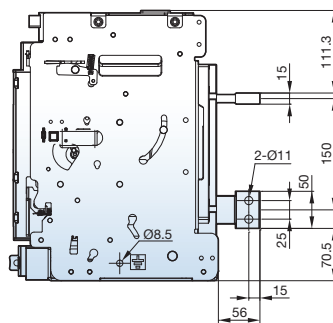
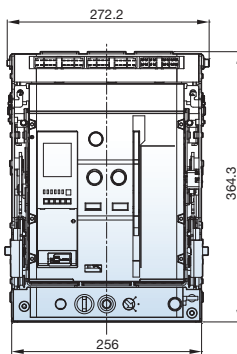

M Type
(Upper-Horizontal type, Lower-Vertical type)

N Type
(Upper-Vertical type, Lower-Horizontal type)

800/1600AF (400~1600A : AW-08/16C)

• 3P [Draw-out P: Plane type / R: Spread type]

(Unit : mm)

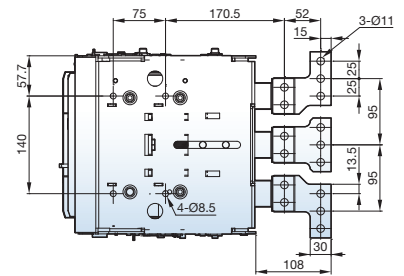
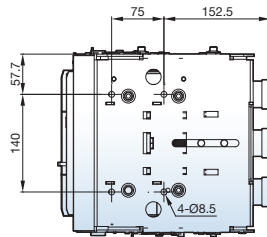
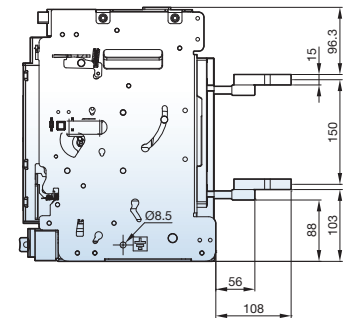
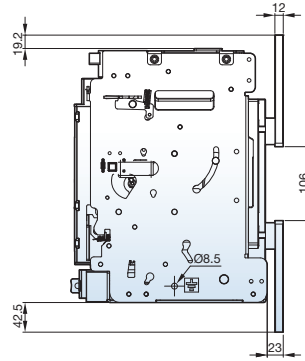
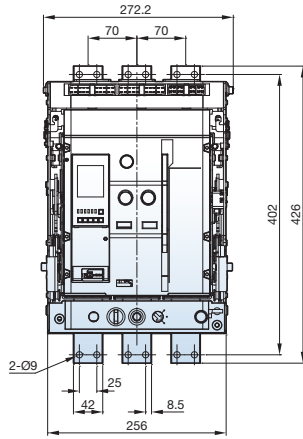

P Type (Plane type)

R Type (Spread type)

• 3P [Draw-out Z: Plane spread type / T: Plane vertical type]

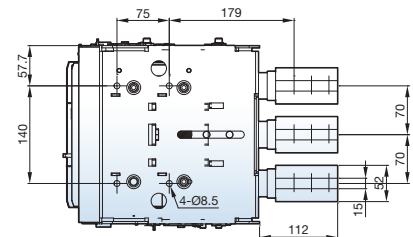
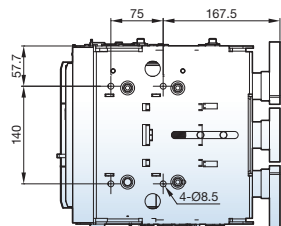
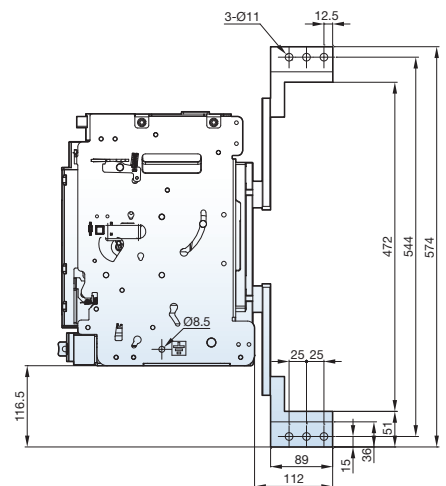
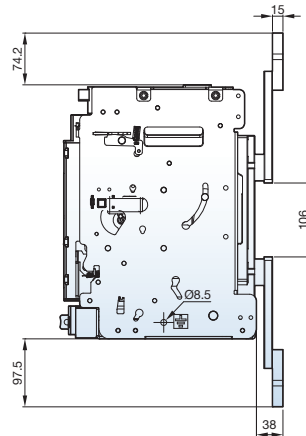
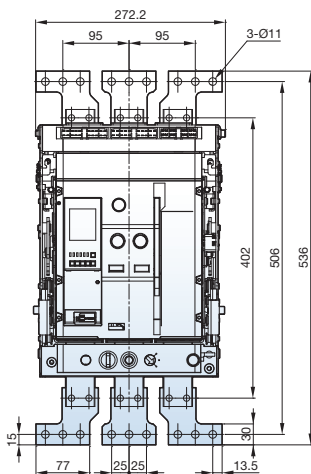

Z Type (Plane spread type)

T Type (Plane vertical type)

Dimensions

800/1600AF (400~1600A : AW-08/16C)

• 3P [Draw-out X: Cable lug type]

(Unit : mm)

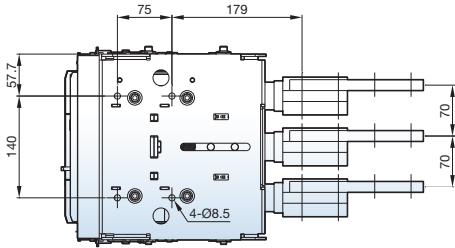
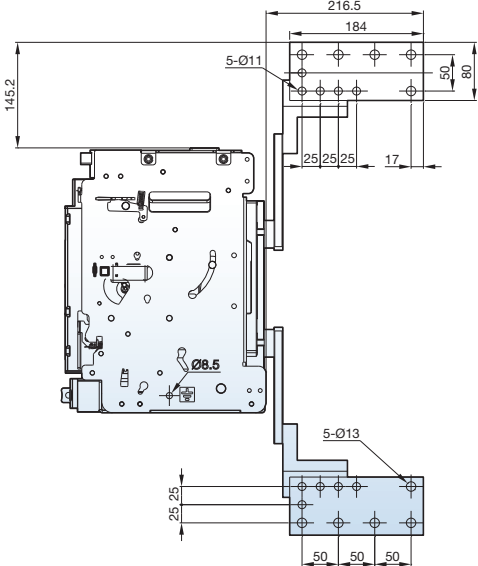
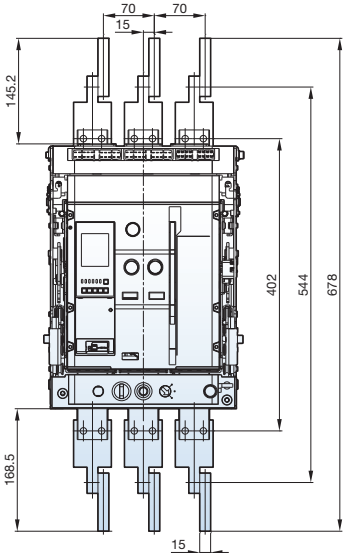

X Type (Cable lug type)

800/1600AF (400~1600A : AW-08/16C)

• 4P [Draw-out H: Horizontal type / V: Vertical type]

(Unit : mm)

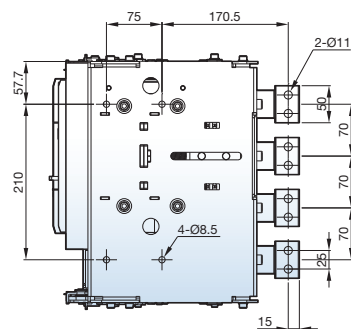
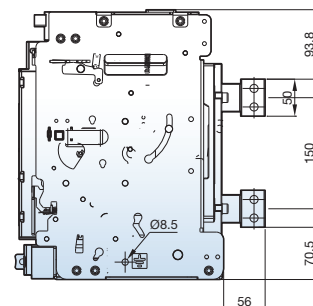
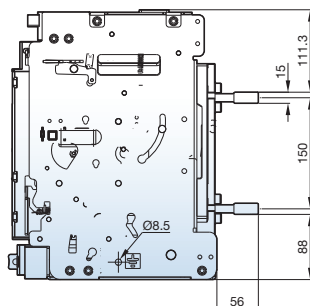
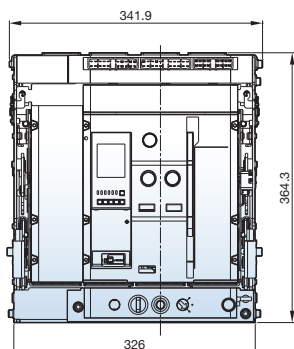

H Type (Horizontal type)

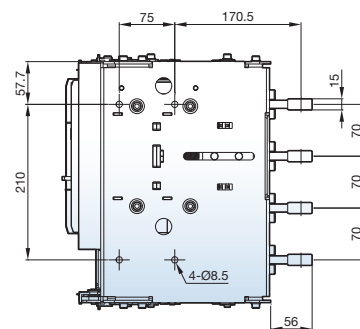

V Type (Vertical type)

• 4P [Draw-out M: Upper-Horizontal type, Lower-Vertical type / N: Upper-Vertical type, Lower-Horizontal type]

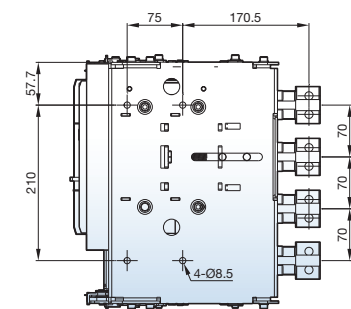
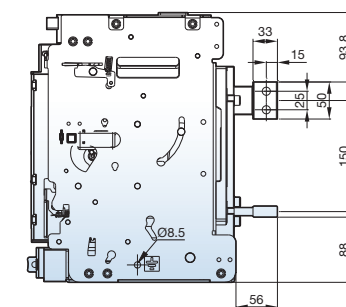
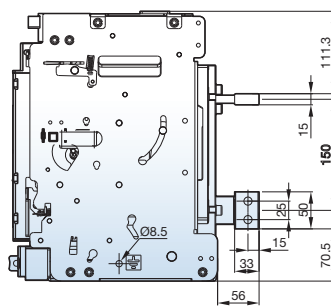
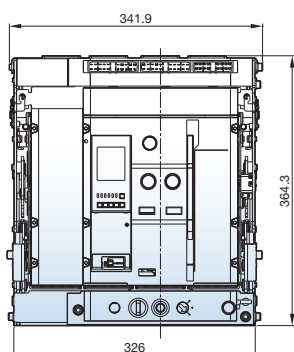

M Type
(Upper-Horizontal type, Lower-Vertical type)

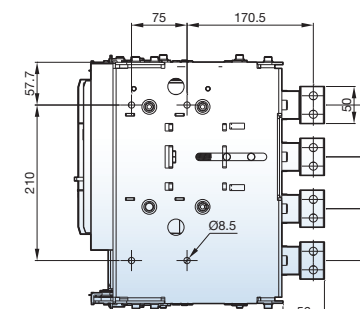

N Type
(Upper-Vertical type, Lower-Horizontal type)

Dimensions

800/1600AF (400~1600A : AW-08/16C)

• 4P [Draw-out P: Plane type / R: Spread type]

(Unit : mm)

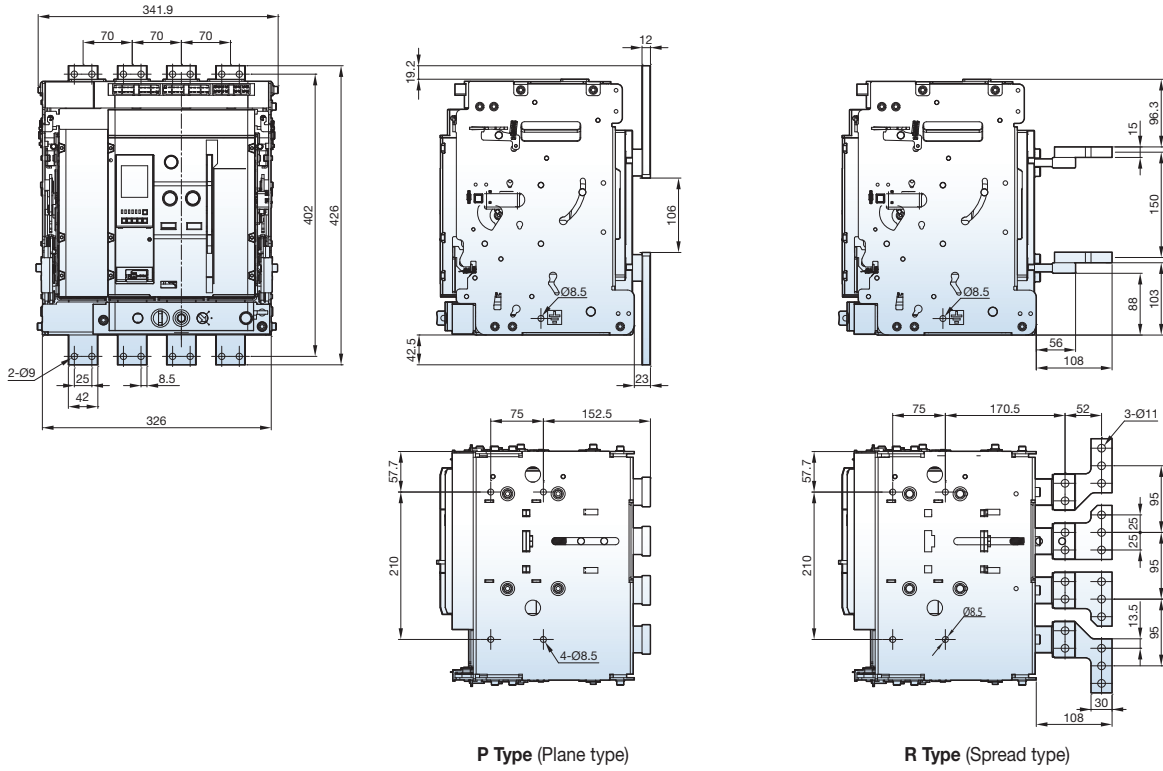

• 4P [Draw-out Z: Plane spread type / T: Plane vertical type]

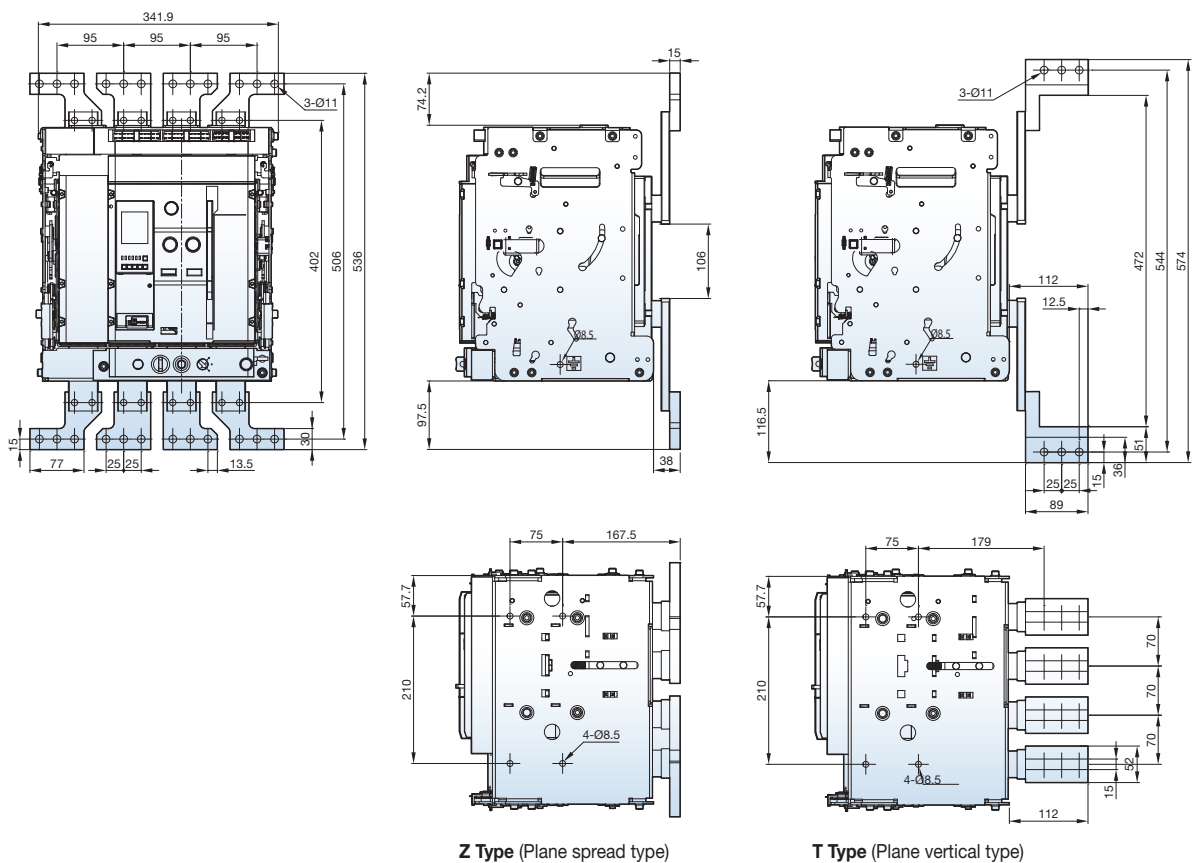

800/1600AF (400~1600A : AW-08/16C)

• 4P [Draw-out X: Cable lug type]

(Unit : mm)

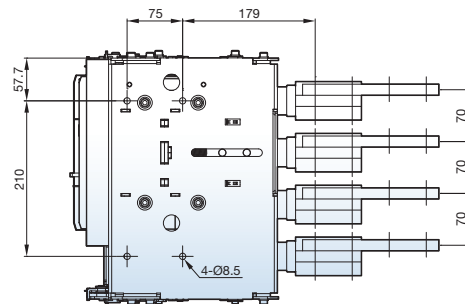
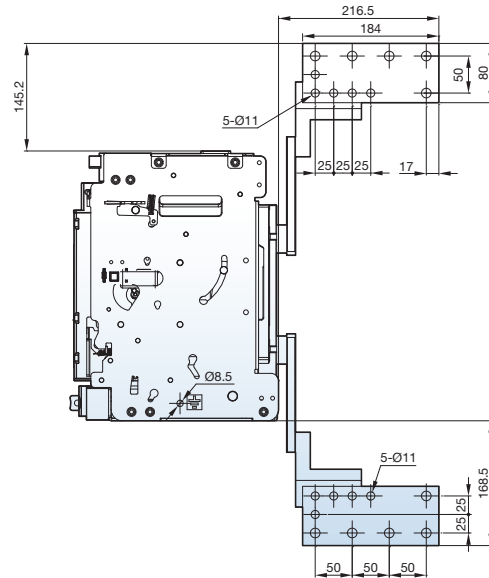
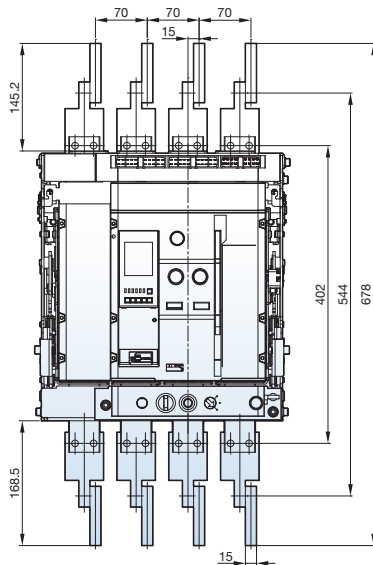

X Type (Cable lug type)

Draw-out Door Frame: DF

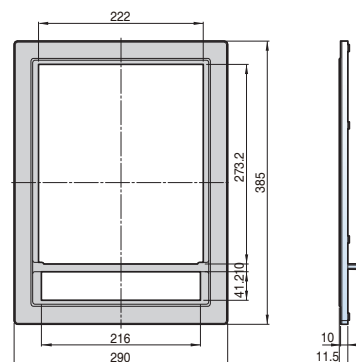

Dimensions

1600AF Fixed type (200~1600A : AV/AW-06~16D)

(Unit : mm)

Front view

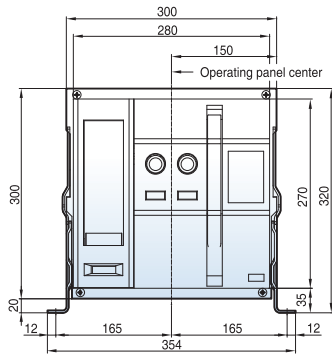

3P

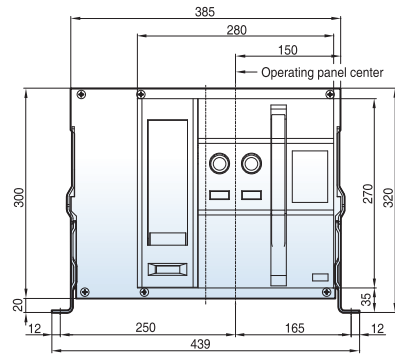

4P

Vertical type

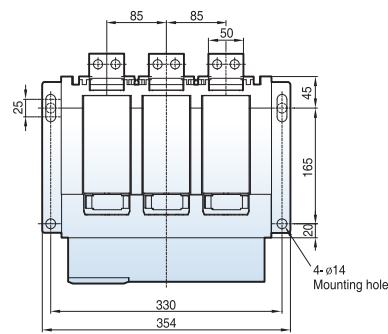

3P

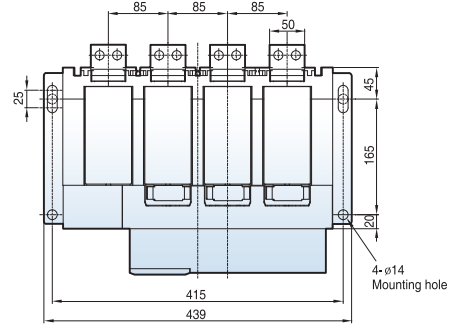

4P

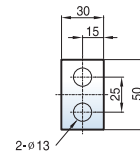
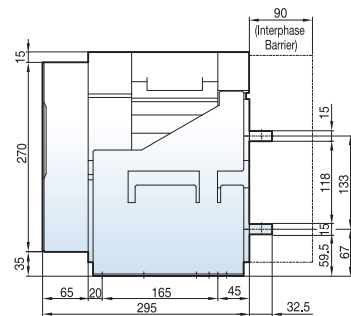

<Conductor>

Door Frame: DF (AH-D/E)

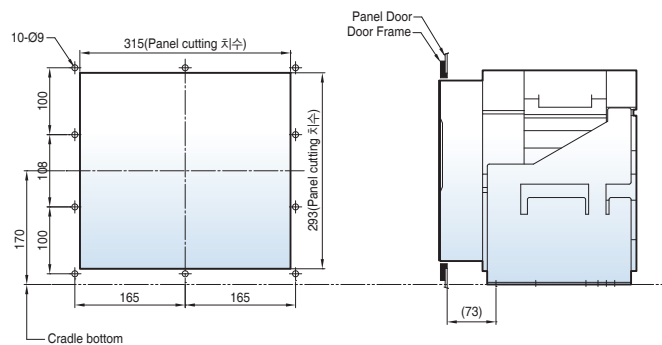

Note) The dimensions are for fixed type.

1600AF Fixed type (200~1600A : AV/AW-06~16D)

(Unit : mm)

Horizontal type

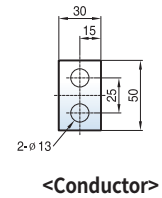
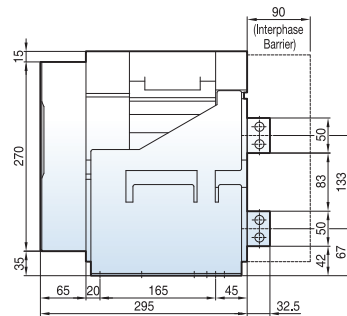
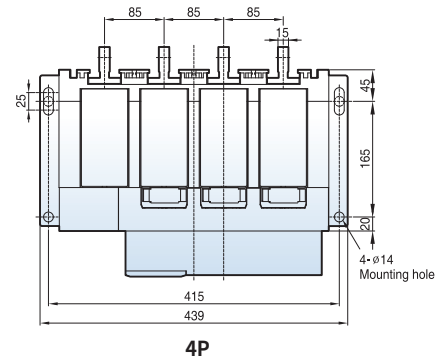
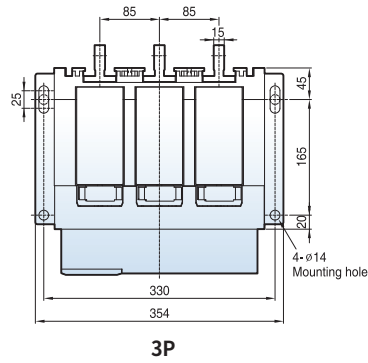

Front connection type

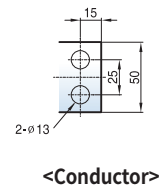
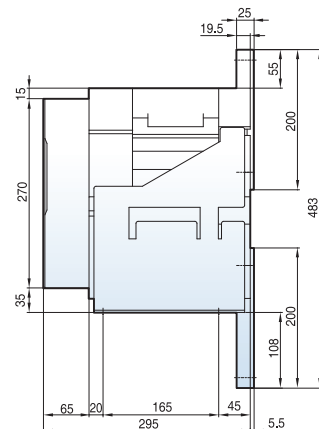
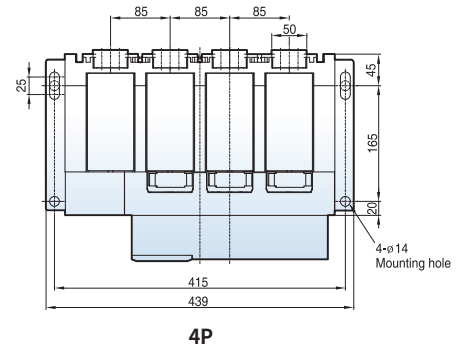
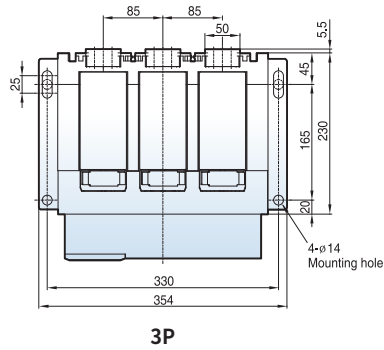

Dimensions

1600AF Draw-out type (200~1600A : AV/AW-06~16D)

(Unit : mm)

Front view

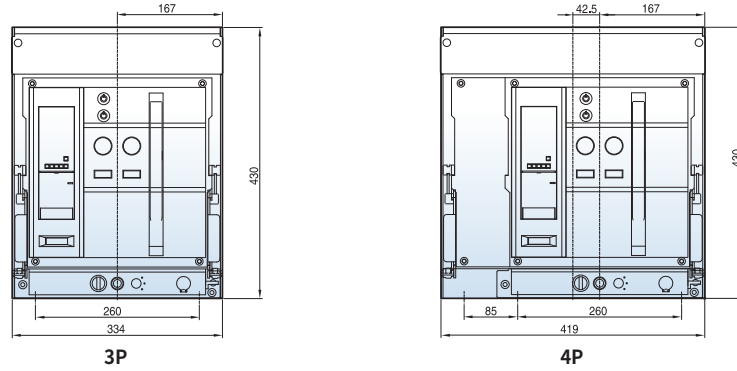

Vertical type

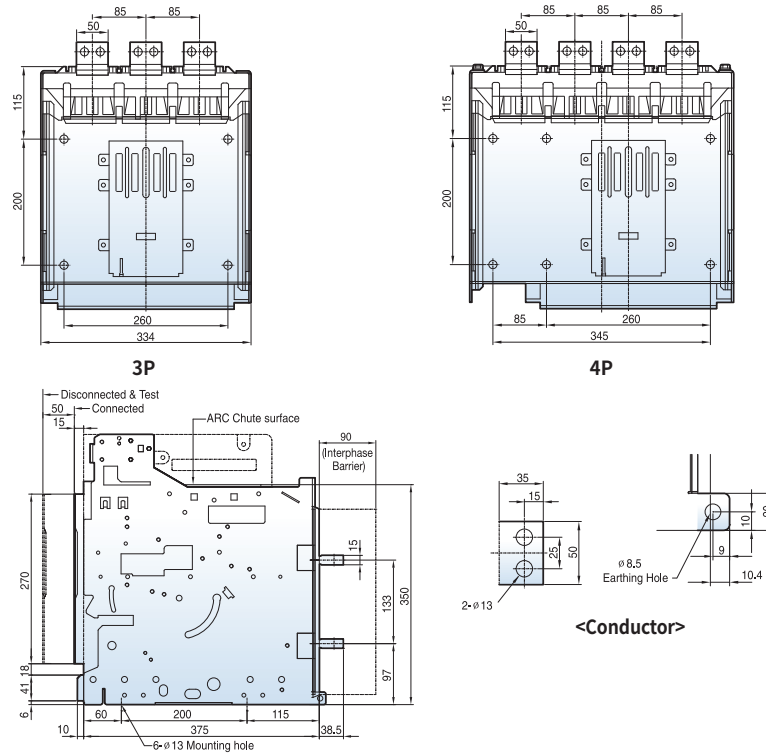

Door Frame: DF (AV-D/E)

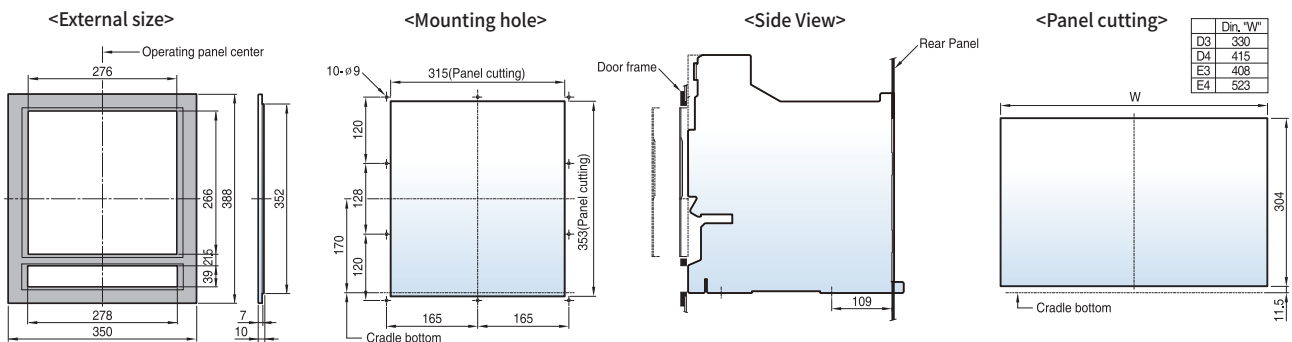

Note) The dimensions are for drawout type.

1600AF Draw-out type (200~1600A : AV/AW-06~16D)

(Unit : mm)

Horizontal type

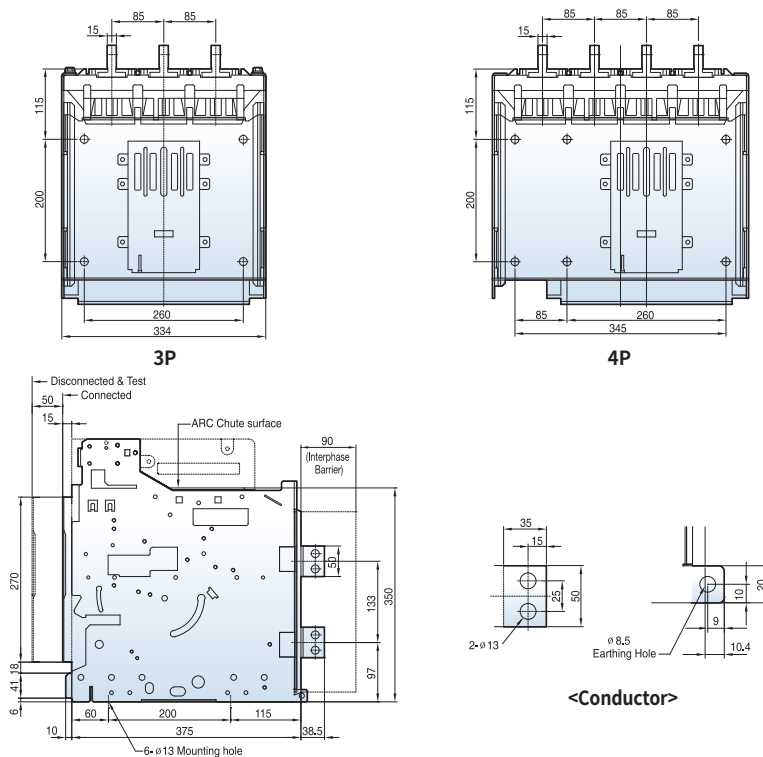

Front connection type

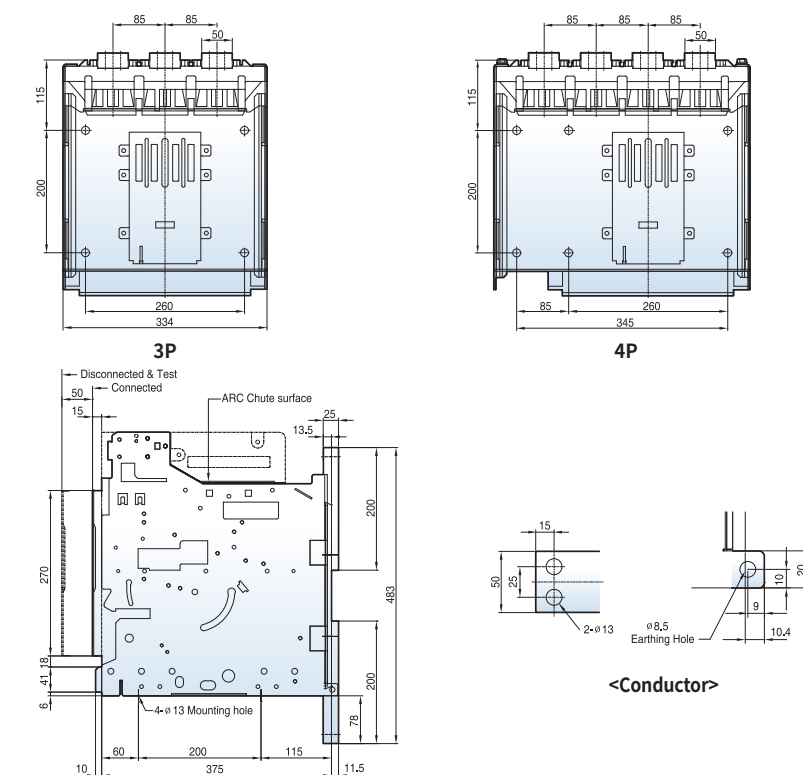

Dimensions

Fixed type 2000AF (2000A: AV/AW-20D)

(Unit : mm)

Front view

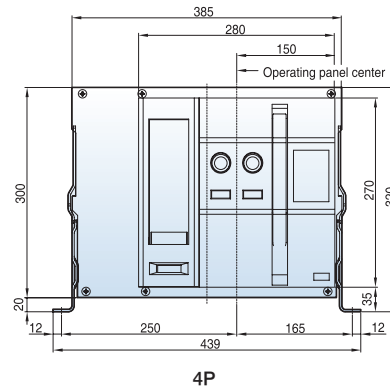
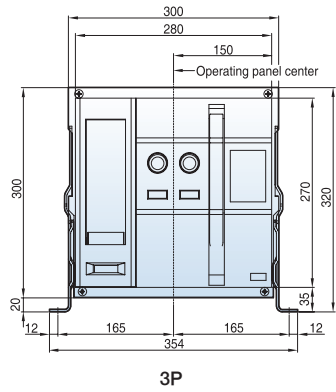

Vertical type

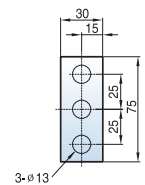
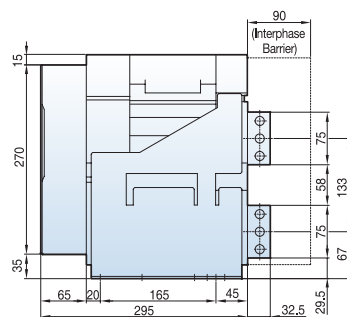
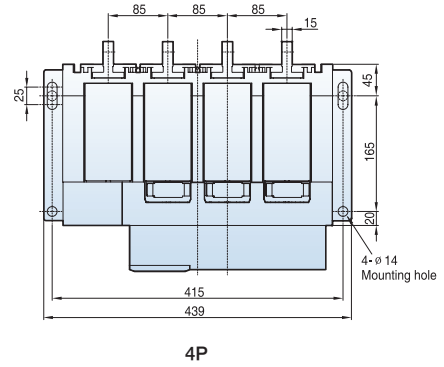
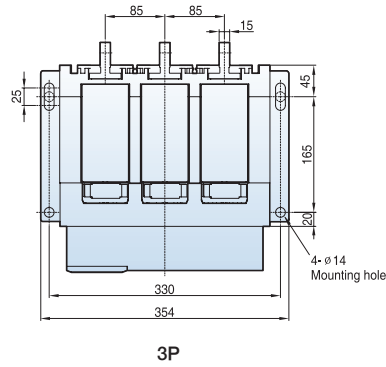

<Conductor>

Draw-out type 2000AF (2000A: AV/AW-20D)

(Unit : mm)

Front view

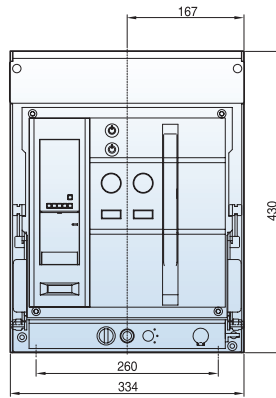

3P

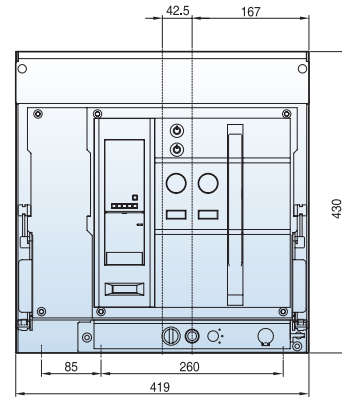

4P

Vertical type

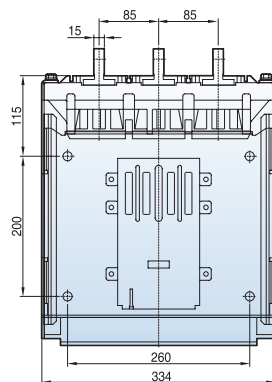

3P

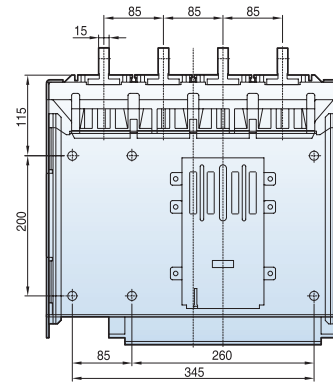

4P

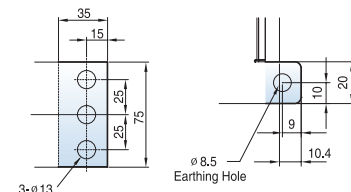
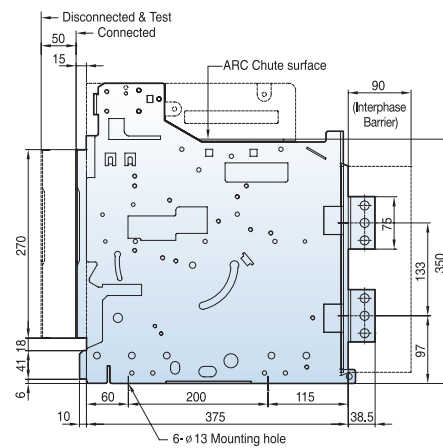

<Conductor>

Dimensions

3200AF Fixed type (400~3200A : AV/AW-06~32E)

(Unit : mm)

Front view

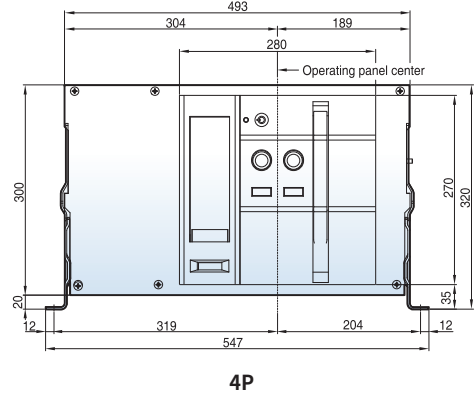
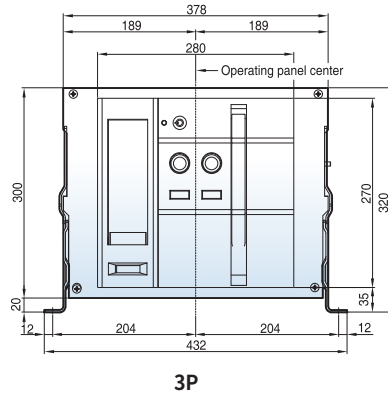

Vertical type

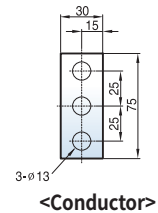
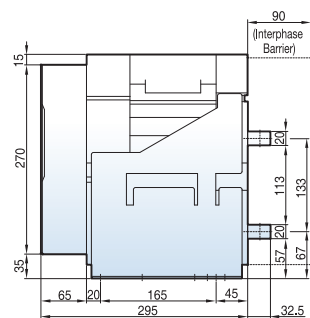
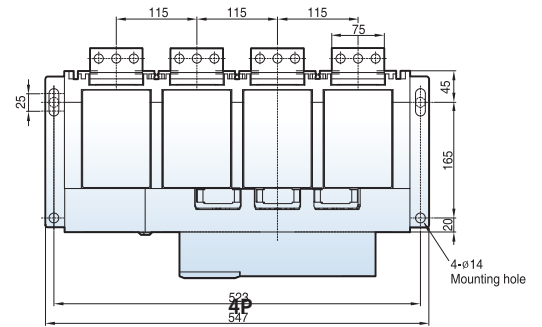
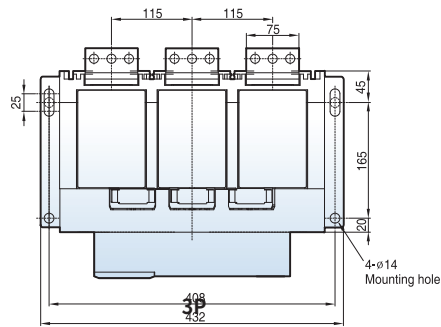

3200AF Fixed type (400~3200A : AV/AW-06~32E)

(Unit : mm)

Horizontal type

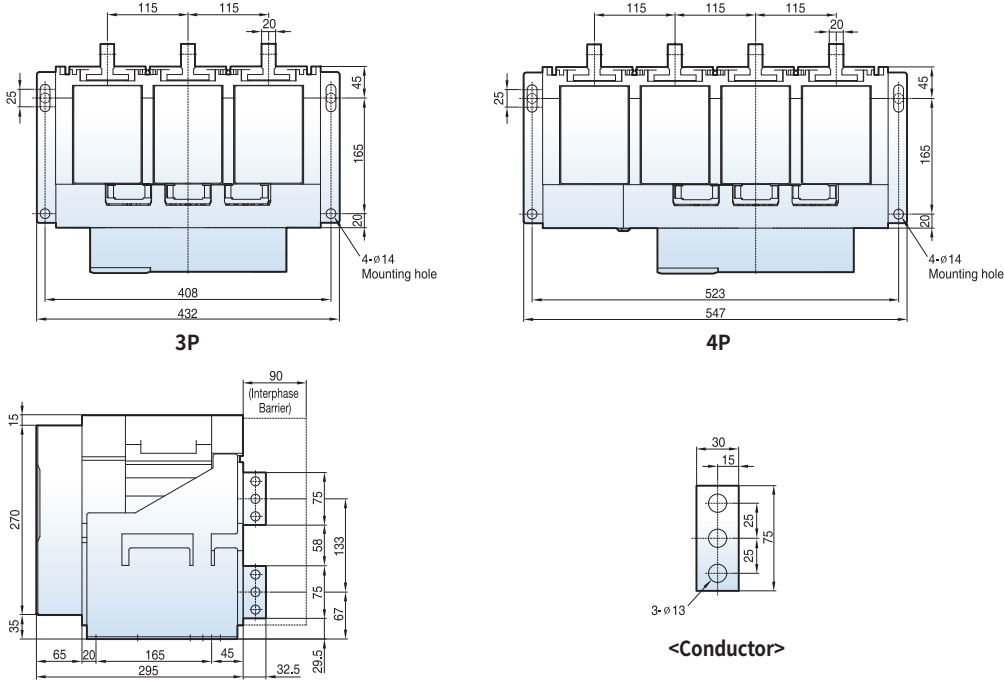

Front connection type

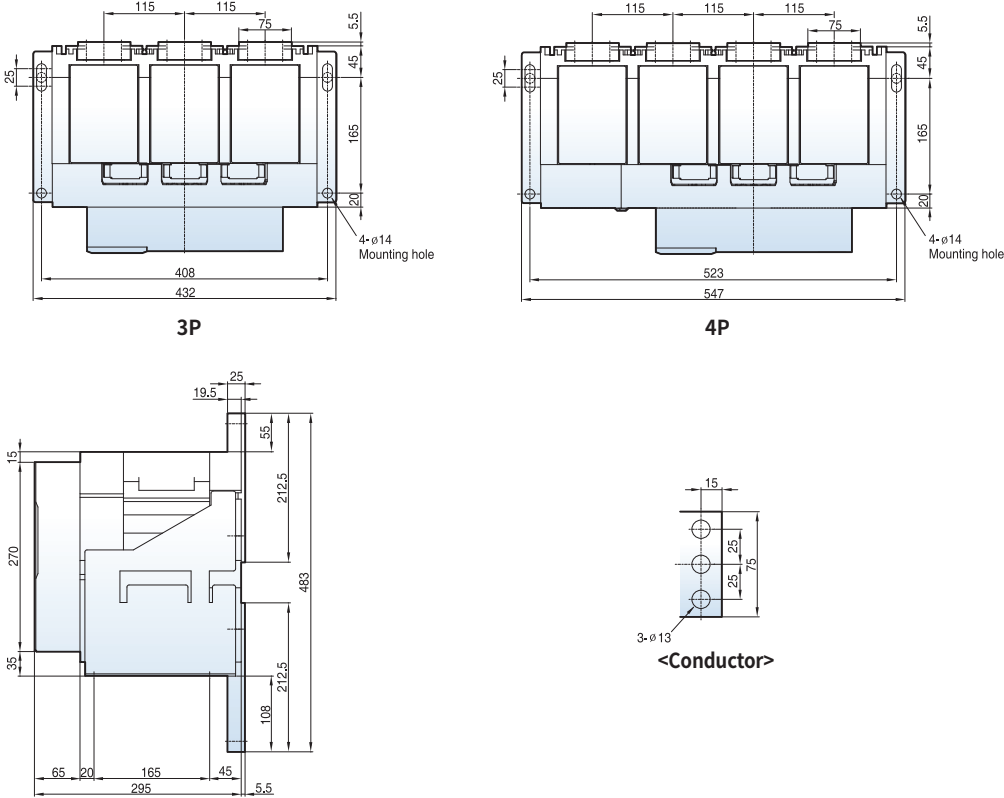

Dimensions

3200AF Draw-out type (400~3200A : AV/AW-06~32E)

(Unit : mm)

Front view

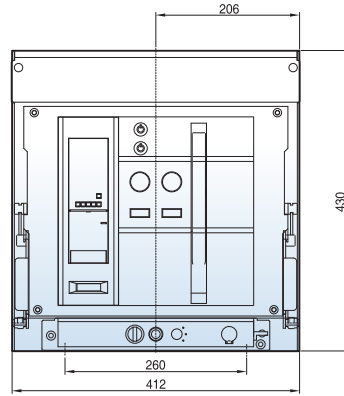

3P

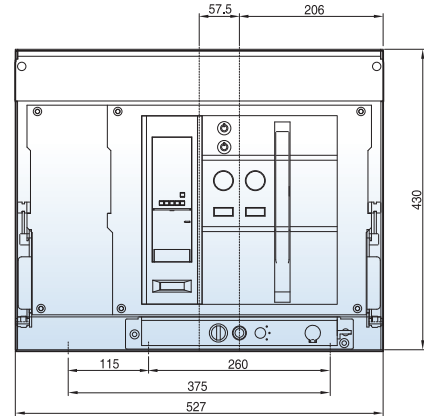

4P

Vertical type

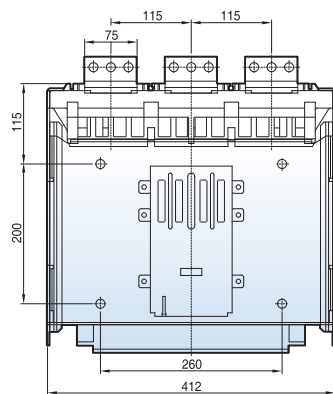

3P

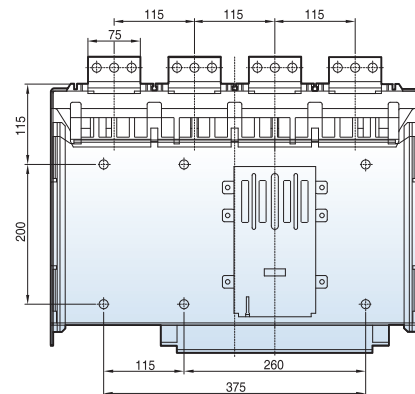

4P

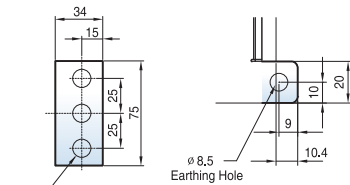
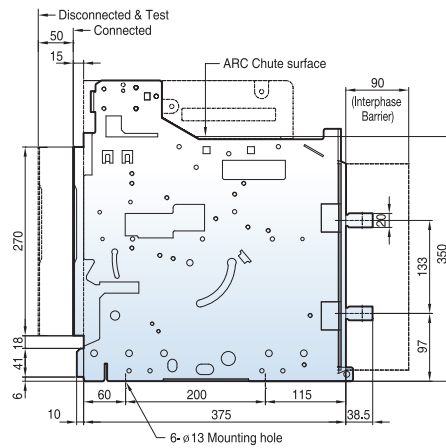

<Conductor>

3200AF Draw-out type (400~3200A : AV/AW-06~32E)

(Unit : mm)

Horizontal type

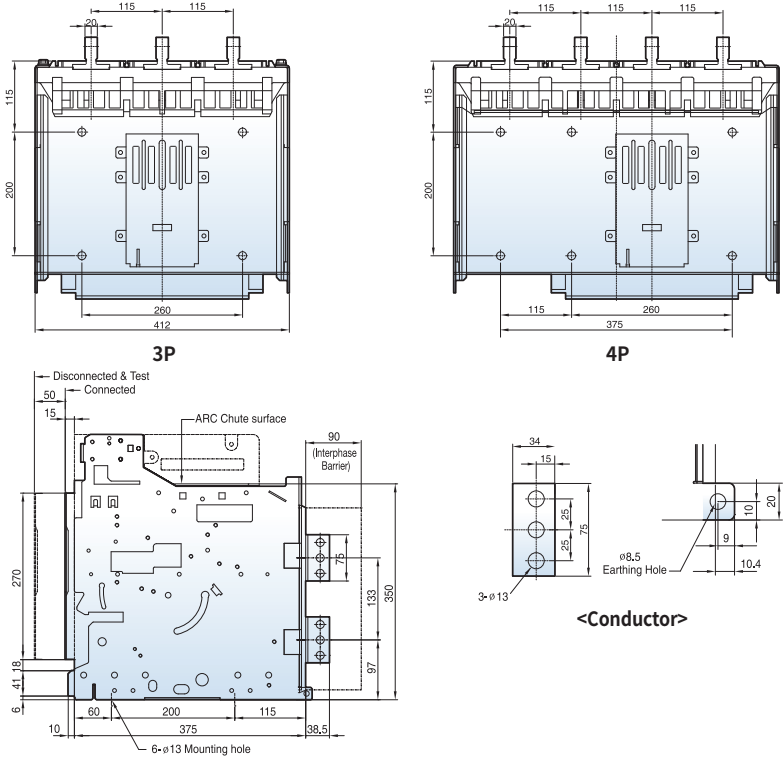

Front connection type

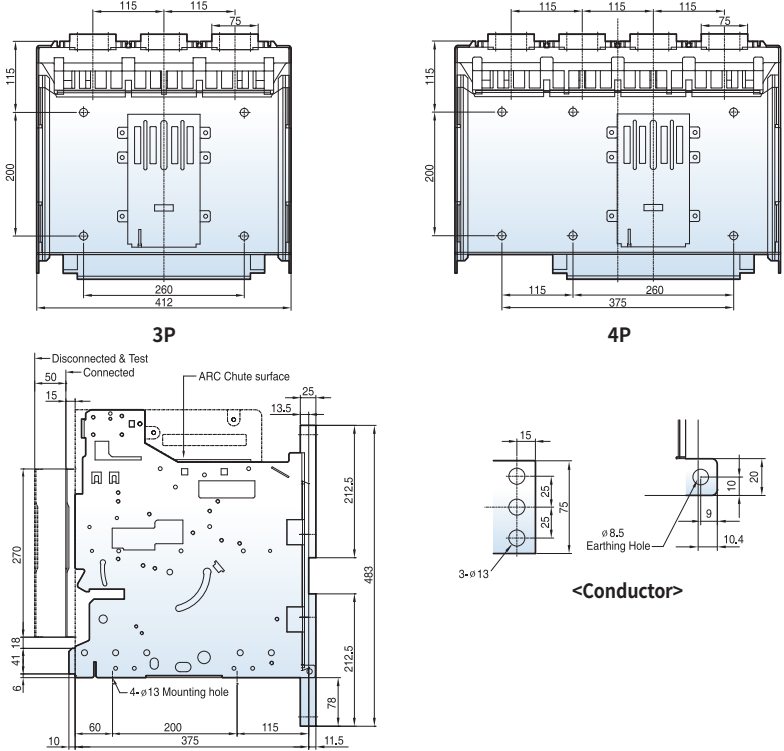

Dimensions

Fixed type 4000AF (4000A: AV/AW-40E)

(Unit : mm)

Front view

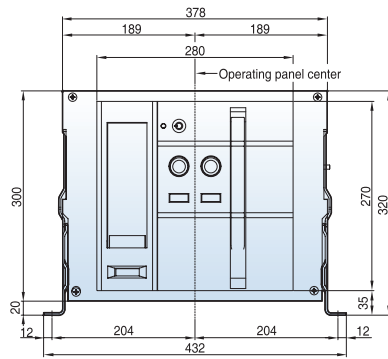

3P

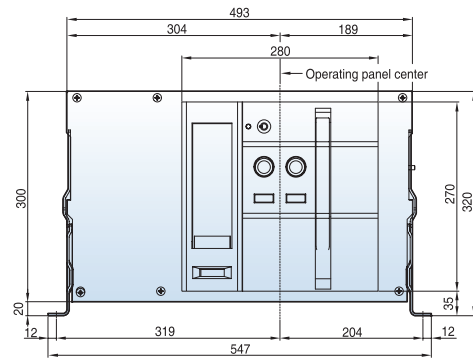

4P

Vertical type

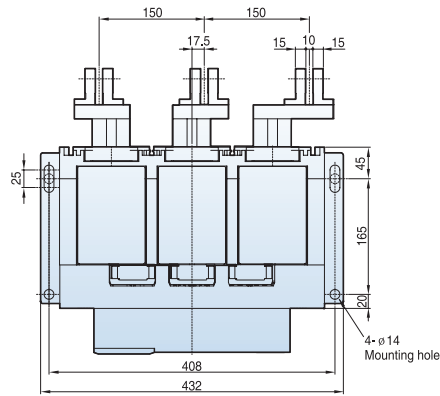

3P

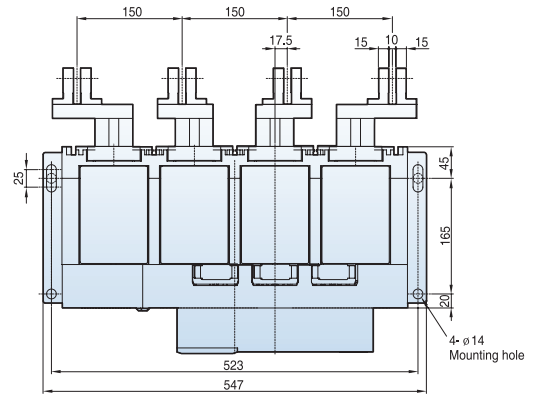

4P

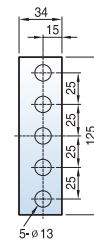
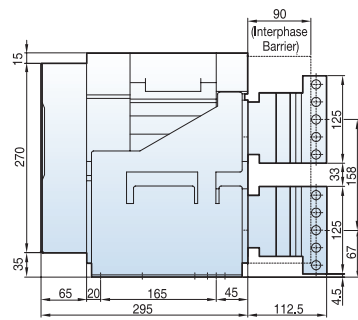

<Conductor>

Draw-out type 4000AF (4000A: AV/AW-40E)

(Unit : mm)

Front view

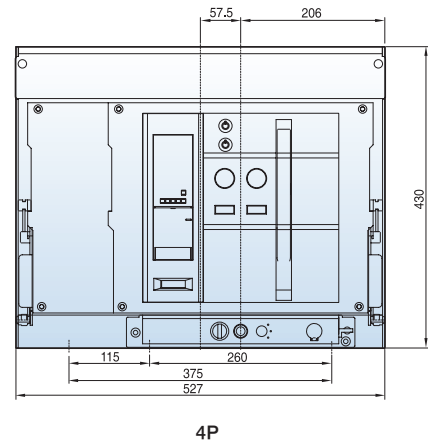
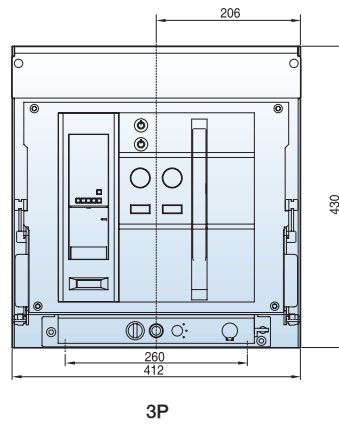

Vertical type

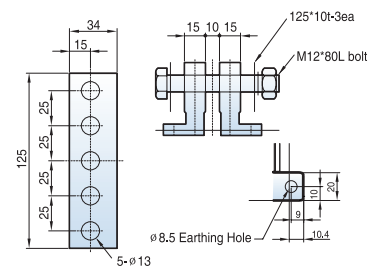
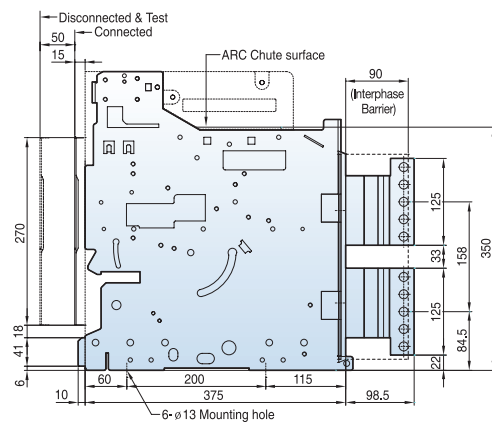
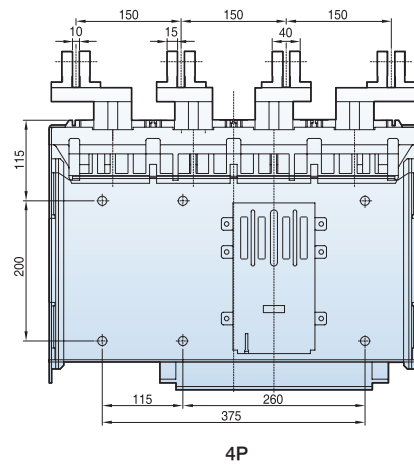
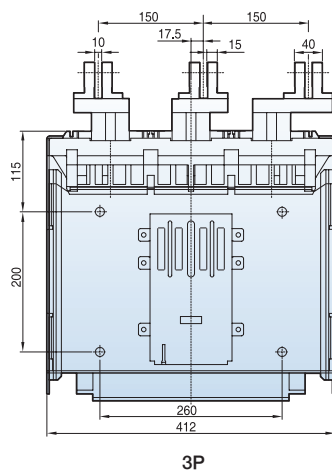

<Conductor>

Technical information

ACB Derating

■ Temperature derating (D-frame)

Type	Drawout														
Connection type	Horizontal or plane							Vertical							
Ambient temperature	40	45	50	55	60	65	70	40	45	50	55	60	65	70	
AV-08D	800	→						800	→						
AV-10D	1000	→						1000	→						
AV-13D	1250	→	1220	1180	1130	1080	1030	1250	→	1235	1190	1150	1090		
AV-16D	1600	1580	1530	1470	1420	1360	1300	1600	→	1550	1490	1430	1360		
AV-20D	2000	1950	1880	1810	1740	1670	1590	2000	→	1910	1840	1760	1680		

Type	Fixed														
Connection type	Horizontal or plane							Vertical							
Ambient temperature	40	45	50	55	60	65	70	40	45	50	55	60	65	70	
AV-08D	800	→						800	→						
AV-10D	1000	→						1000	→						
AV-13D	1250	→			1230	1180	1120	1250	→			1240	1180		
AV-16D	1600	→		1580	1520	1450	1390	1600	→		1530	1460			
AV-20D	2000	→	1990	1920	1840	1760	1680	2000	→		1940	1860	1770		

* Ambient temperature is greater than 60 C, consult us.

■ Temperature derating (E-frame)

Type	Drawout													
Connection type	Horizontal or plane							Vertical						
Ambient temperature	40	45	50	55	60	65	70	40	45	50	55	60	65	70
AV-20E	2000	→	1930	1860	1790	1710	1630	2000	→	1960	1880	1800	1720	
AV-25E	2500	2460	2370	2290	2200	2100	2000	2500	→	2410	2310	2220	2110	
AV-32E	3200	3100	3000	2890	2770	2660	2530	3200	→	3150	3040	2920	2800	2670
AV-40E	4000	3800	3660	3530	3390	3240	3090	4000	→	3850	3710	3570	3410	3260

Type	Fixed														
Connection type	Horizontal or plane							Vertical							
Ambient temperature	40	45	50	55	60	65	70	40	45	50	55	60	65	70	
AV-20E	2000	→			1960	1890	1810	1720	2000	→			1900	1810	
AV-25E	2500	→			2390	2300	2200	2100	2500	→			2420	2320	2210
AV-32E	3200	→	3100	2990	2870	2750	2620	3200	→	3150	3020	2900	2760		
AV-40E	4000	3950	3810	3470	3530	3380	3220	4000	→	3870	3710	3560	3390		

* Ambient temperature is greater than 60 C, consult us.

■ Altitude derating

	2000m	3000m	4000m
Withstand voltage [V]	3500	3150	2800
Insulation voltage [V]	1250	1125	1000
Operational voltage [V]	900	810	720
	1000	900	800
	1150	1035	920
Current compensation constant	1×In	0.98×In	0.96×In



Memo

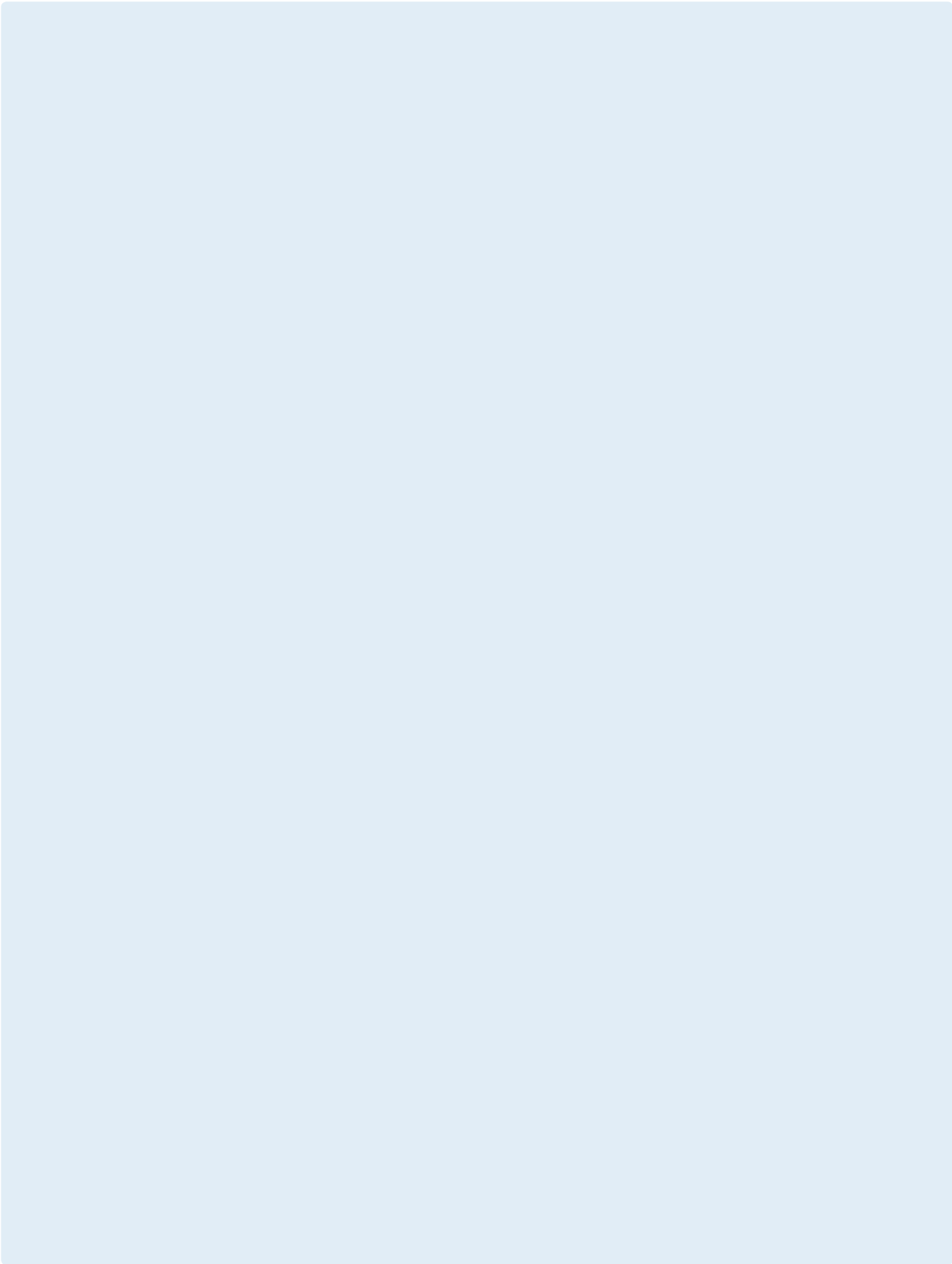

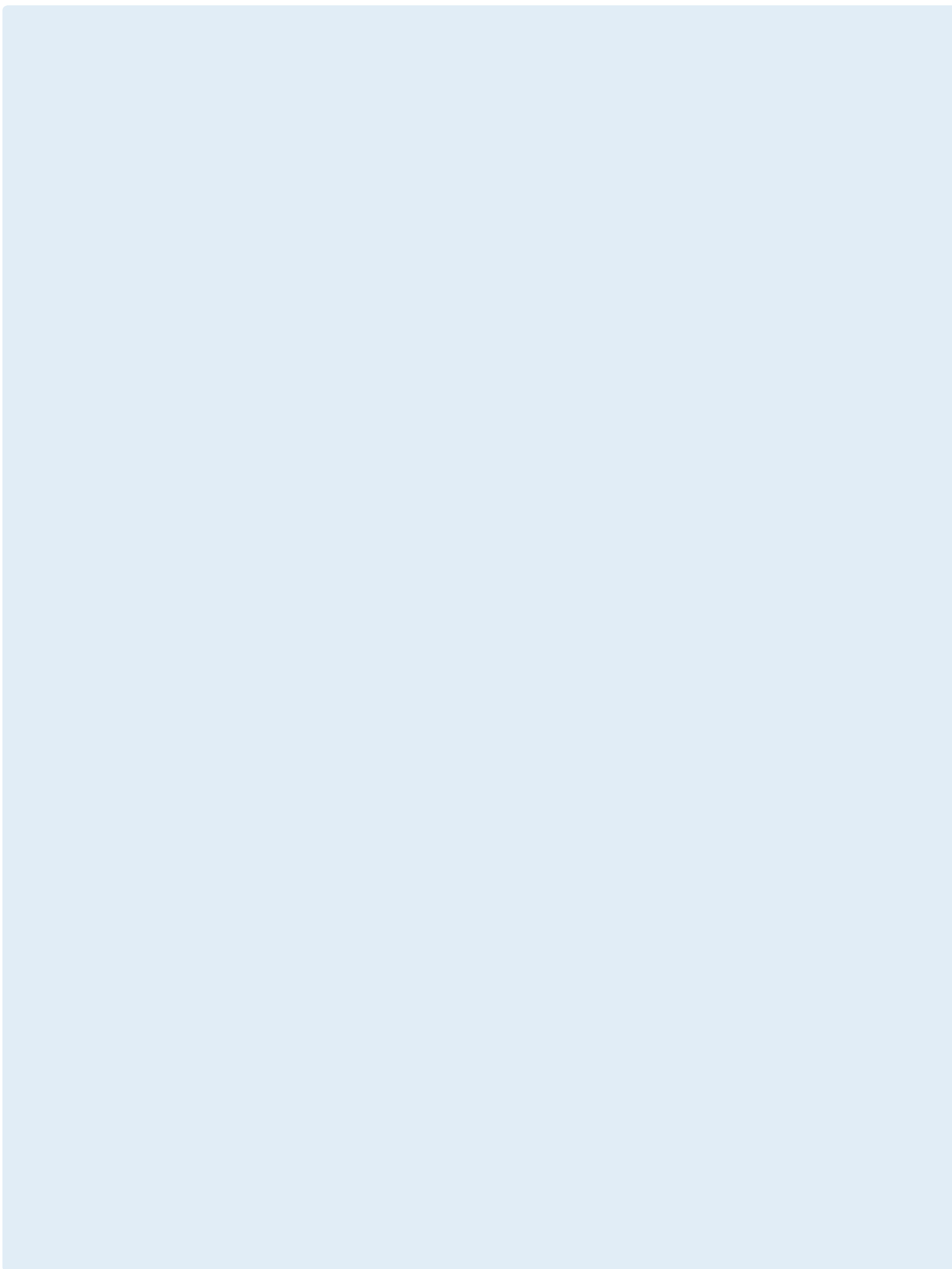



Safety Instructions

- For your safety, please read user's manual thoroughly before operating.
- Contact the nearest authorized service facility for examination, repair, or adjustment.
- Please contact qualified service technician when you need maintenance. Do not disassemble or repair by yourself!
- Any maintenance and inspection shall be performed by the personnel having expertise concerned.



- According to The WEEE Directive, please do not discard the device with your household waste.



www.ls-electric.com

■ **Headquarter**

127 LS-ro (Hogye-dong) Dongan-gu, Anyang-si, Gyeonggi-Do, 14119, Korea

■ **Seoul Office**

LS Yongsan Tower, 92, Hangang-daero, Yongsan-gu, Seoul, 04386, Korea
Tel. 82-2-2034-4916, 4684, 4429

■ **Overseas Subsidiaries**

- **LS ELECTRIC Japan Co., Ltd. (Tokyo, Japan)**
Tel: 81-3-6268-8241 E-Mail: japan@ls-electric.com
- **LS ELECTRIC (Dalian) Co., Ltd. (Dalian, China)**
Tel: 86-411-8730-5872 E-Mail: china.dalian@lselectric.com.cn
- **LS ELECTRIC (Wuxi) Co., Ltd. (Wuxi, China)**
Tel: 86-510-6851-6666 E-Mail: china.wuxi@lselectric.com.cn
- **LS ELECTRIC Vietnam Co., Ltd. (Hanoi, Vietnam)**
Tel: 84-93-631-4099 E-Mail: vietnam@ls-electric.com
- **LS ELECTRIC Middle East FZE (Dubai, U.A.E.)**
Tel: 971-4-886-5360 E-Mail: middleeast@ls-electric.com
- **LS ELECTRIC Europe B.V. (Hoofddorp, Netherlands)**
Tel: 31-20-654-1424 E-Mail: europartner@ls-electric.com
- **LS ELECTRIC America Inc. (Chicago, USA)**
Tel: 1-800-891-2941 E-Mail: sales.us@lselectricamerica.com
- **LS ENERGY SOLUTIONS LLC (Charlotte, USA)**
Tel: 1-704-587-4051 E-Mail: cmfeldman@ls-es.com
- **LS ELECTRIC Turkey Co., Ltd. (Istanbul, Turkey)**
Tel: 90-212-806-1252 E-Mail: turkey@ls-electric.com

■ **Overseas Branches**

- **LS ELECTRIC Tokyo Office (Japan)**
Tel: 81-3-6268-8241 E-Mail: tokyo@ls-electric.com
- **LS ELECTRIC Beijing Office (China)**
Tel: 86-10-5095-1631 E-Mail: china@lselectric.com.cn
- **LS ELECTRIC Shanghai Office (China)**
Tel: 86-21-5237-9977 E-Mail: china@lselectric.com.cn
- **LS ELECTRIC Guangzhou Office (China)**
Tel: 86-20-3818-2883 E-Mail: china@lselectric.com.cn
- **LS ELECTRIC Chengdu Office (China)**
Tel: 86-28-8670-3201 E-Mail: china@lselectric.com.cn
- **LS ELECTRIC Qingdao Office (China)**
Tel: 86-532-8501-2065 E-Mail: china@lselectric.com.cn
- **LS ELECTRIC Nanjing Office (China)**
Tel: 86-25-8467-0005 E-Mail: china@lselectric.com.cn
- **LS ELECTRIC Bangkok Office (Thailand)**
Tel: 66-90-950-9683 E-Mail: thailand@ls-electric.com
- **LS ELECTRIC Jakarta Office (Indonesia)**
Tel: 62-21-2933-7614 E-Mail: indonesia@ls-electric.com
- **LS ELECTRIC Moscow Office (Russia)**
Tel: 7-499-682-6130 E-Mail: info@lselectric-ru.com
- **LS ELECTRIC America Western Office (Irvine, USA)**
Tel: 1-949-333-3140 E-Mail: america@ls-electric.com
- **LS ELECTRIC India Office (India)**
Tel: 91-80-6142-9108 E-Mail: info_india@ls-electric.com
- **LS ELECTRIC Singapore Office (Singapore)**
Tel: 65-6958-8162 E-Mail: singapore@ls-electric.com



Technical Question or After-sales Service

Customer Center-Quick Responsive Service, Excellent technical support | **82-1644-5481**