

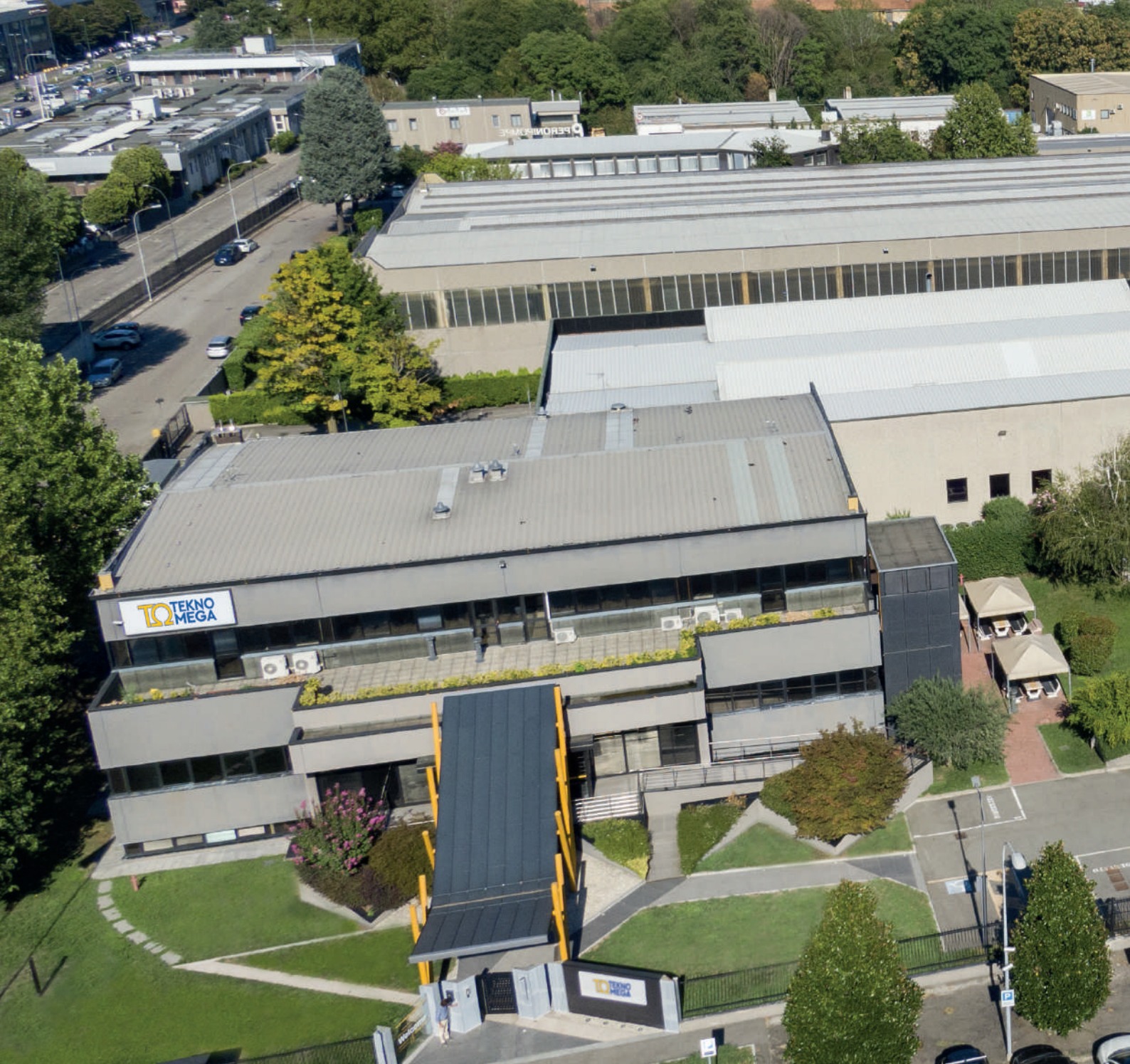

ELECTRICAL POWER SOLUTIONS

TK **TEKNO**
MEGA

Evolving together



We help the electrical and industrial market to deliver innovative projects providing all-round reliable solutions and a competent, timely, and professional service.



OUR HISTORY

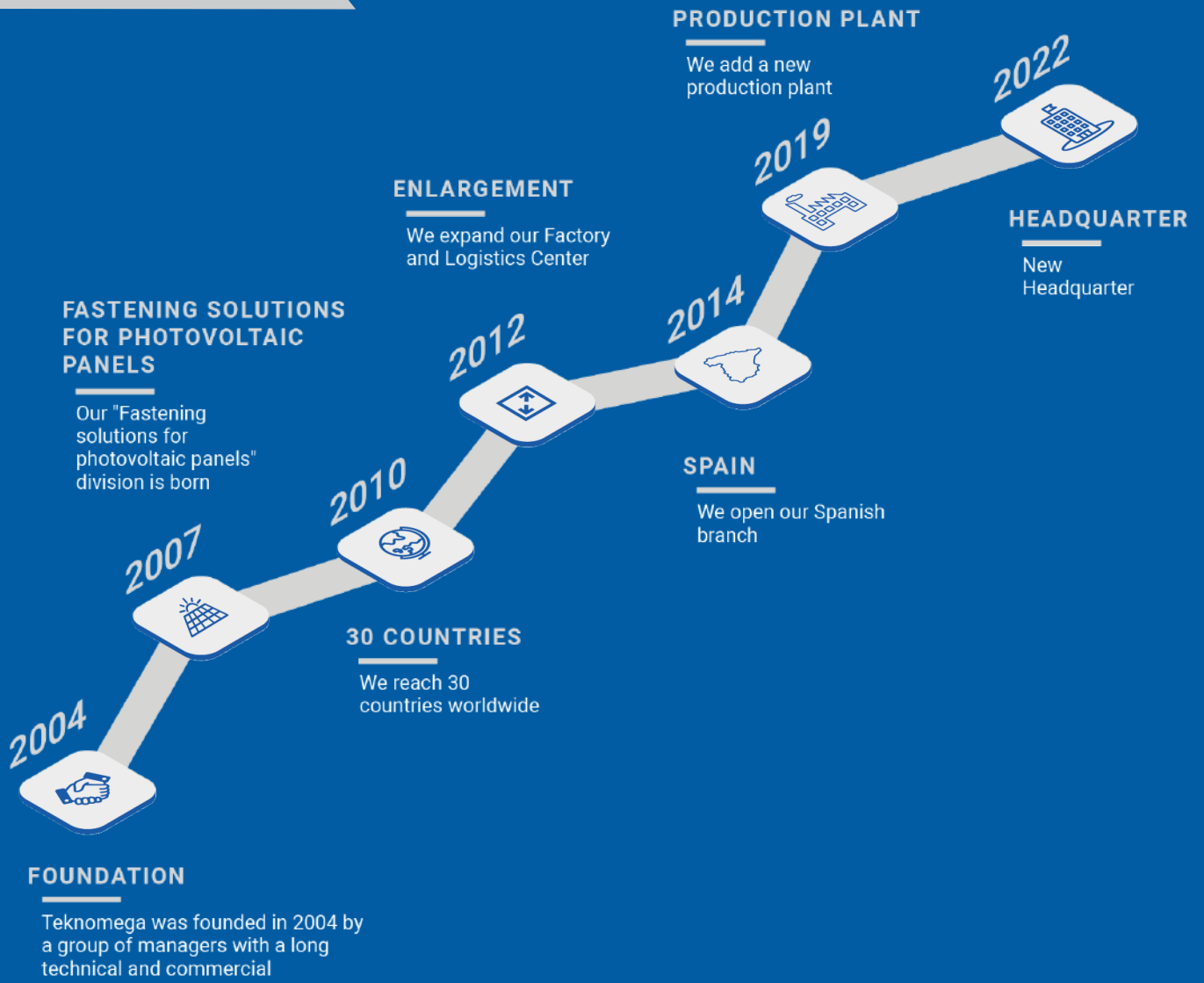

WE ARE PRESENT IN OVER 65 COUNTRIES



We are committed to improving every day to reach increasingly more challenging targets. We are defined by our tenacity, reactivity, and determination. We are building a successful path and we intend to continue to follow it with ambition and audacity.



VISION

Our positive impact on the electrical and industrial market, being one of the most relevant companies, consists in providing innovative solutions and great reliability. In the community, it consists in being an example of care, inclusion, and transparency.

MISSION

Our Road Map includes:

- the reliability of a rigorous but flexible organization, oriented towards excellent customer services.
 - solidity as a tool for investments, to grow in volume and culture, and to comply with norms and regulations.
- the consolidation of the workplace as a positive environment in which people can recognise themselves, increase their uniqueness while being part of a team, and feel a sense of belonging.



PURPOSE

TEKNOMEGA exists to leave a mark: being able to generate trust in the market and in the community and through this attract clients and talent.



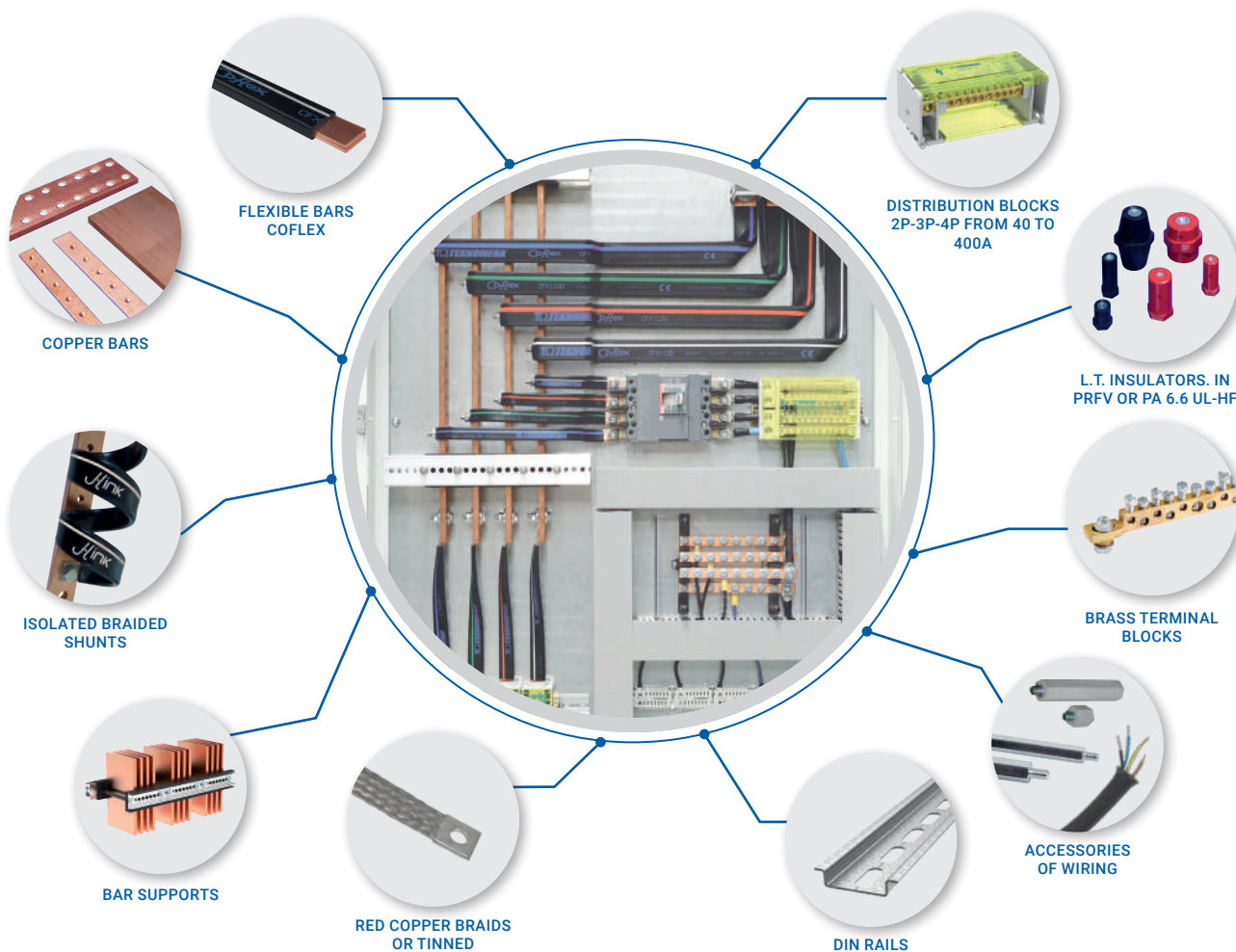

TEKNOMEGA offers a complete and synergic range of **ELECTRICAL POWER SOLUTIONS** and components for panel builders, machine builders, OEMs, with the great advantage of being assisted by a qualified partner with great field experience.

What TEKNOMEGA proposes complies with reference standards as well as with the requirements of the latest guidelines relevant to the safety and materials used. In addition to specific product regulations, compliance with REACH and RoHS directives when applicable is ensured.

Most products of this catalogue have been electrically and mechanically **TESTED** and **PROVEN**. The catalog products are normally available at our warehouses; TEKNOMEGA can also meet requests of "special" or "customized" products with competence, flexibility and quickness.

NOTE

For values (e.g., Current Intensity) related to parameters not specified in the catalog tables (e.g., temperature values), refer to QWARE downloadable from our website www.teknomega.it.

FLEXIBLE BARS, ACCESSORIES AND TOOLS

• COFLEX - Insulated copper flexible bars	Page 12
• COFLEX PLUS Insulated copper flexible bars	Page 17
• COFLEX COLOR - COFLEX PACKAGING	Page 20
• Preformed flexible bars as per drawing	Page 21
• Fixing plates	Page 22
• Flexible bar support	Page 22
• Hand tools	Page 23

BRAIDED SHUNTS

• J-LINK - Insulated copper braided shunts	Page 24
• J-LINK PLUS	Page 25
• J-LINK COLOR	Page 27

SPECIAL CONNECTIONS

• Braided power shunts	Page 30
• Laminated power shunts	Page 30

BRAIDS

• Prefabricated earthing braids	Page 32
• Copper braids in coils	Page 34

BAR AND ACCESSORIES

• Threaded copper bars	Page 37
• Prepunched copper bars	Page 38
• Solid copper bars	Page 39
• Solid aluminium bars	Page 40
• Accessories for bars	Page 41

BAR SUPPORTS

• Ω TOP - Universal bar support	Page 45
• Ω TOP JUNIOR - Compact bar support	Page 52
• Ω FLAT - Bar support	Page 54

INSULATORS

• Ω COMPRHEX - Insulators in polyester	Page 58
• Ω COMPRHEX - Spacing columns in polyester	Page 59
• Ω ISO - Insulators in polyamide	Page 60
• Ω ISO - Spacing columns in polyamide	Page 61
• Profiles	Page 62

DISTRIBUTION BLOCKS

• Distribution Block supports	Page 63
• Distribution Block supports in Kit	Page 66
• Ω BLOCK - Distribution Blocks	Page 70
• Ω BLOCK - Compact distribution blocks	Page 76
• Ω BLOCK - Distribution Blocks Quick	Page 80
• Ω BLOCK - Power Terminal Blocks	Page 81
• Ω BLOCK - 1-pole terminal Blocks	Page 83

BRASS TERMINAL BLOCKS

• Earthing bars	Page 85
• Earthing terminals with cable collar	Page 85
• Earthing terminal	Page 86
• Earthing terminal with connections for housing	Page 86
• Double earthing terminal blocks	Page 87
• Double earthing terminal	Page 87
• Terminal block supports	Page 87

WIRING SLEEVES AND TOOLS

• Polyester braided sleeve	Page 89
• Fiberglass and silicone braided sleeve	Page 91
• Spiral sleeve	Page 92
• Tools for wiring sleeves	Page 93

DIN RAILS, TOOLS, HOLDERS AND ACCESSORIES

• DIN rails	Page 94
• Profiles	Page 96
• Tools for DIN rails	Page 97
• Supports for DIN rails	Page 98
• Accessories for DIN rails	Page 99

WIRING ACCESSORIES

• Plastic spacers	Page 100
• Plastic caps	Page 100
• Grommet inserts	Page 100
• Steel spacers	Page 101

LIST OF ALPHANUMERIC CODES	Page 102
-----------------------------------	----------

FLEXIBLE BARS, ACCESSORIES AND TOOLS

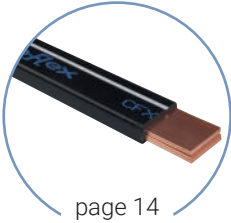

page 14



page 17

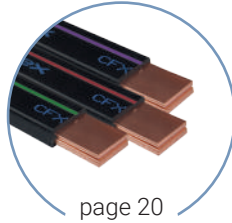

page 20



page 20



page 22



page 23

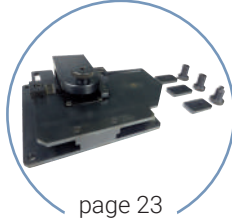

page 23

BRAIDED SHUNTS



page 24



page 25

SPECIAL CONNECTIONS

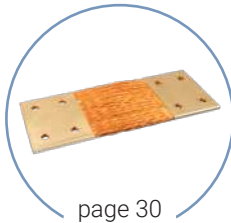

page 30

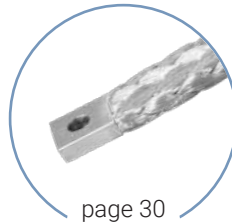

page 30



page 30



page 30

BRAIDS



page 33



page 33

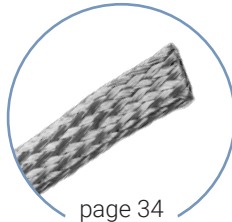

page 34

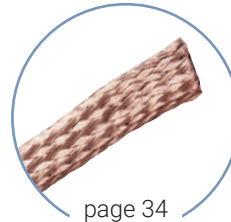

page 34



page 34



page 34



page 35



page 35

BARS AND ACCESSORIES

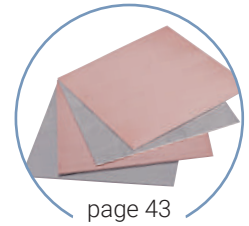
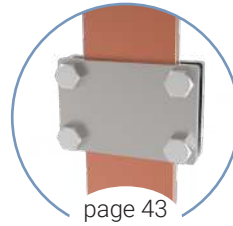
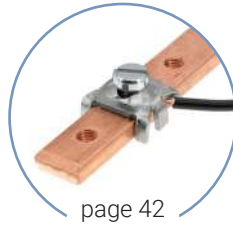
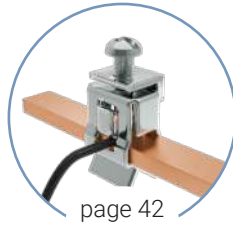
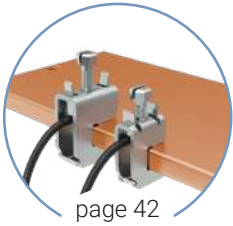
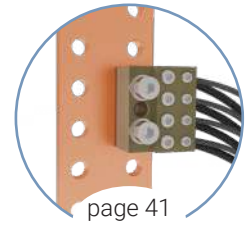
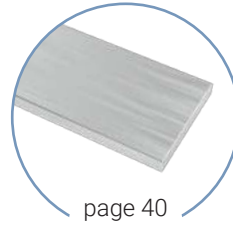
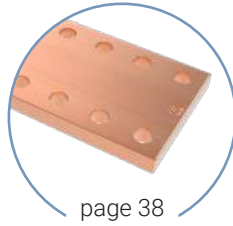

BAR SUPPORTS

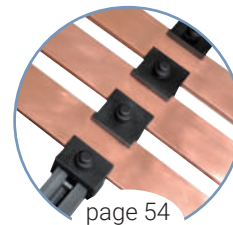
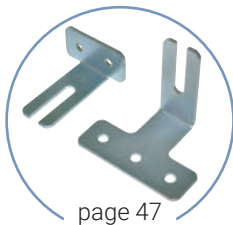
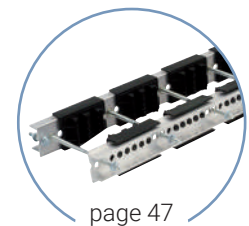
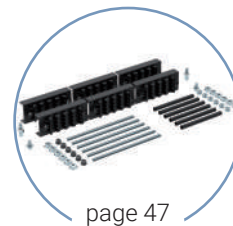
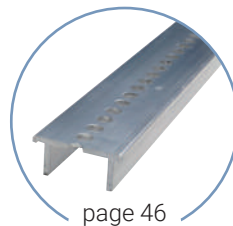
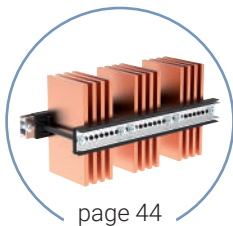

INSULATORS

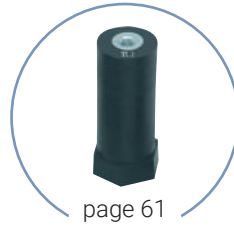

DISTRIBUTION BLOCKS AND ACCESSORIES

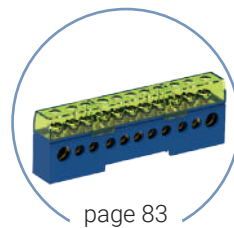
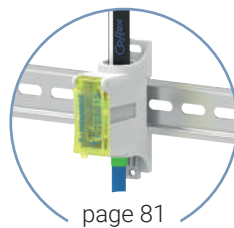
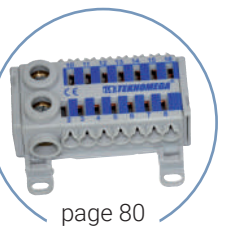
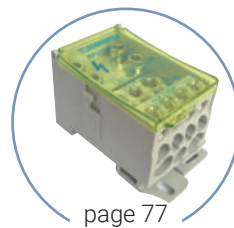
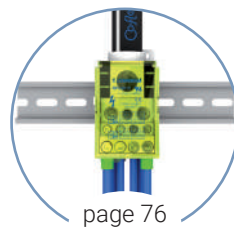
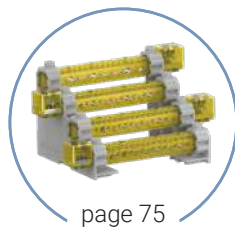
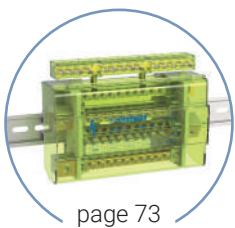
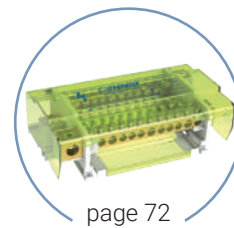
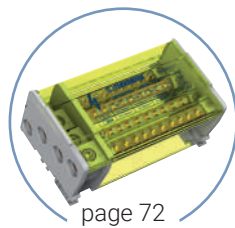
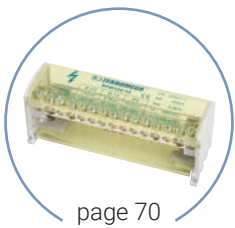
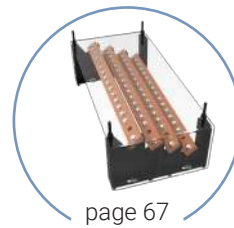
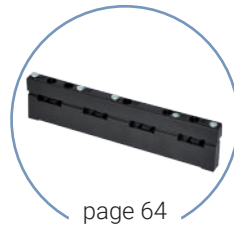
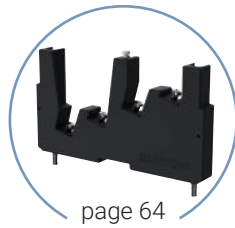

TERMINAL BLOCKS AND ACCESSORIES

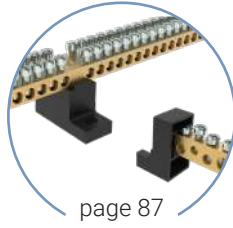
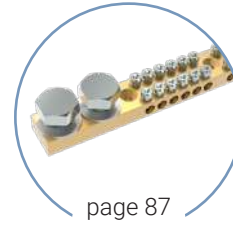
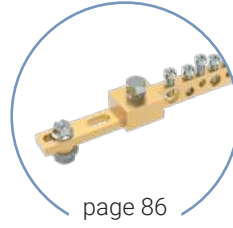
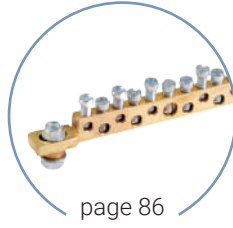
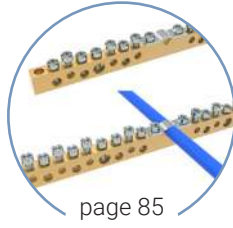
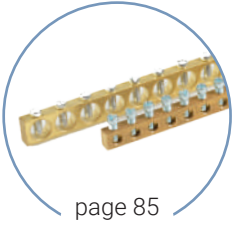

WIRING SLEEVES AND TOOLS



DIN RAILS, TOOLS, HOLDERS AND ACCESSORIES

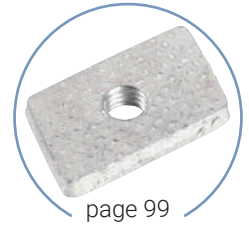
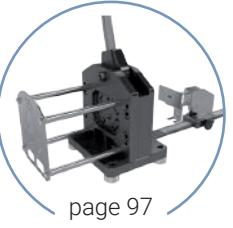
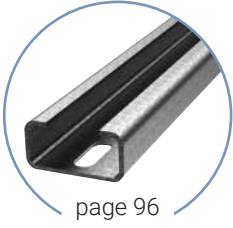
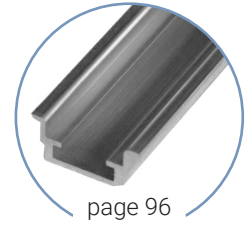
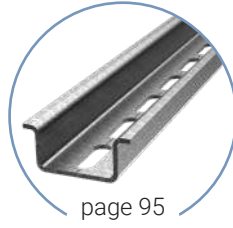
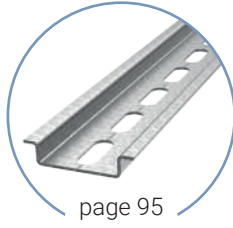
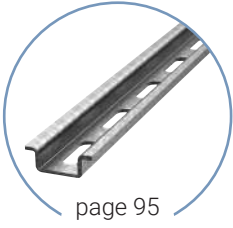

WIRING ACCESSORIES

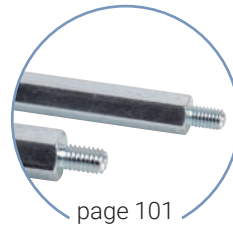
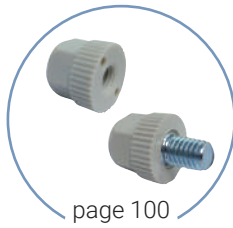
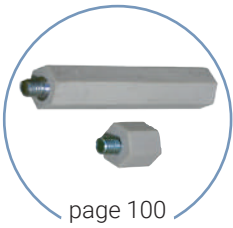

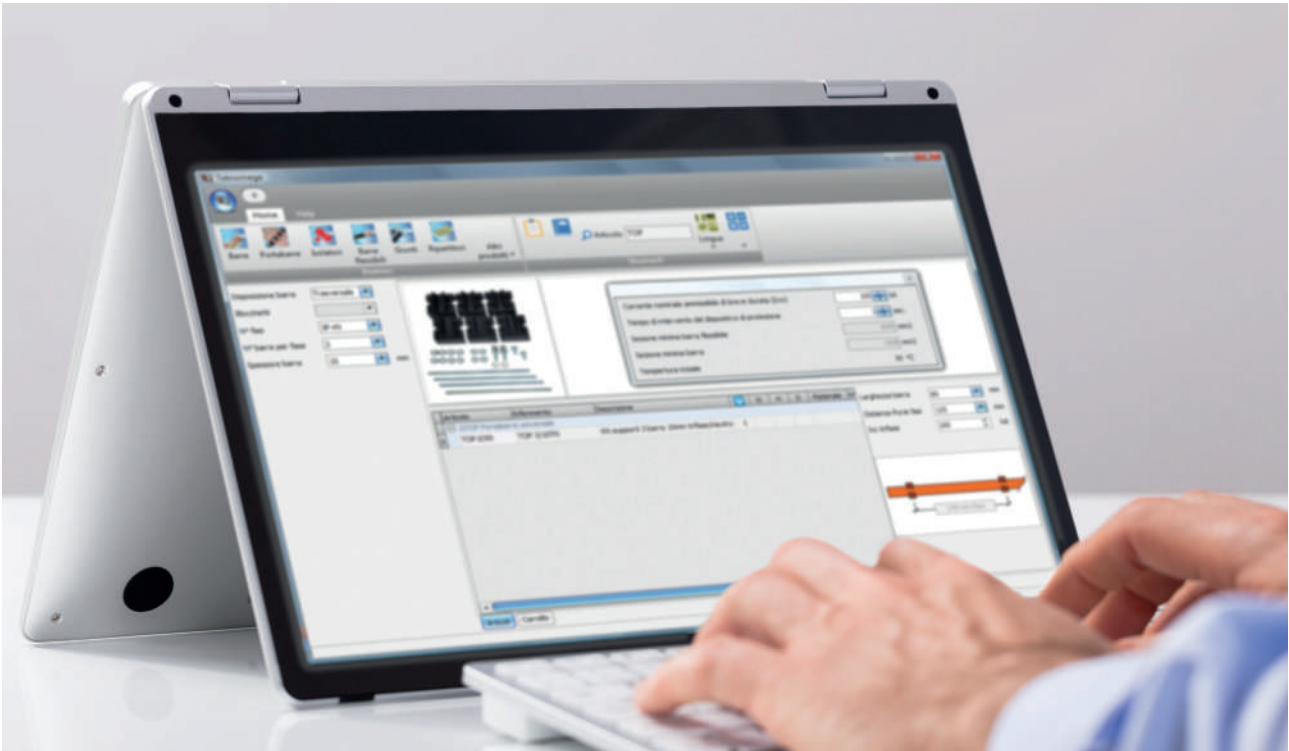

SOFTWARE FOR CALCULATIONS AND PRODUCTS SELECTION FOR PANEL BUILDERS

ΩWARE can calculate electrical parameters, select products for a specific project, calculate the right installation distances, list the chosen products, see the pricelist, the catalogue and the operating instructions, product datasheet and updated pricelists.

Quick and intuitive, ΩWARE will guide you in the selection of products, saving your time and avoiding possible mistakes. desiderata. Download it to our site: www.teknomega.com.

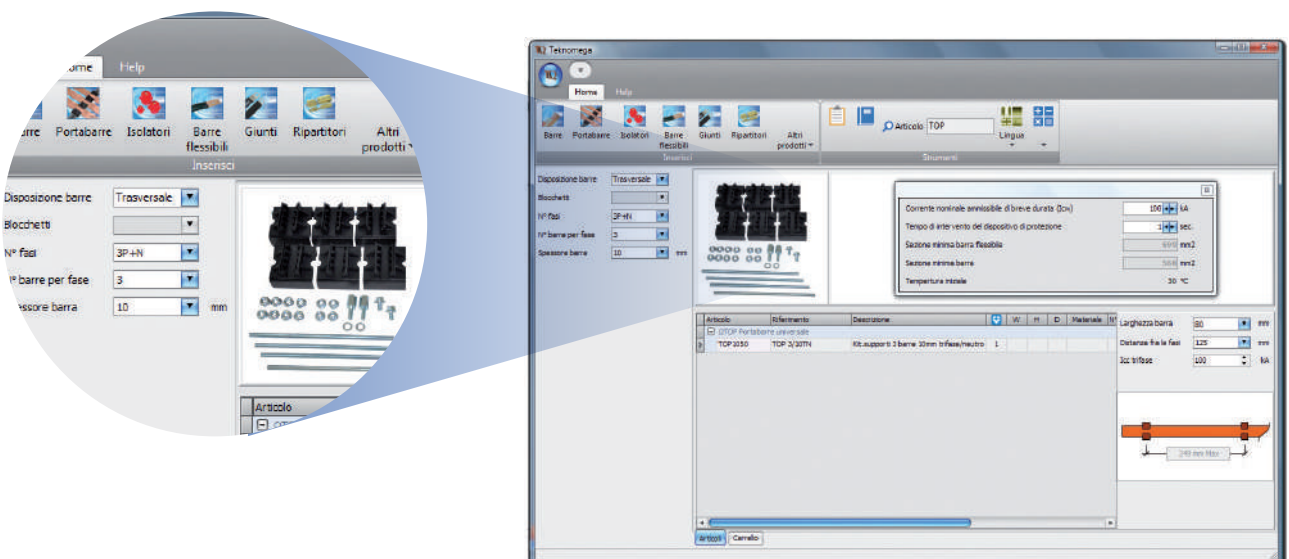



COFLEX, THE 4.0 FLEXIBLE BAR

From a **TEKNOMEGA** new and advanced manufacturing plant, COFLEX, the only “bi-color” flexible bar (patented), distinguishes itself for the high flexibility and excellent look.

COFLEX is the perfect conductor to connect:

- main power supply and electrical equipment (switches, disconnectors, etc.)
- busbar and cabinet / panel board
- transformer and busbar

COFLEX is designed with electrolytic copper laminates, covered with a highly resistant and self extinguishing insulation which guarantees an excellent electrical insulation, even with humid or aggressive environment, or high temperature.

Electrical connections using COFLEX are much easier than using standard methods such as cable or plain bar. Connections with COFLEX, making holes straight on the laminates, are safe and reliable and they make a panel board installation easier and faster.

ADVANTAGES COMPARED TO PLAIN BAR

- Easy shaping also for big sizes
- With same cross section, higher ampacity and safety improvement
- Reduction of material used and dimensions
- Savings in the cost and installation time of bar supports and/or insulators since the lessee is insulated

ADVANTAGES COMPARED TO CABLE

- Higher electrical ampacity with same cross section
- Reduction of dimensions for your installation
- Reduction of length and number of conductors
- Cost and time saving compared to the usage of cable terminals
- Zero electrical resistance without cable terminals



SAVING OF TIME

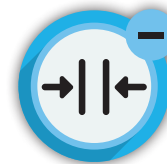

FOOTPRINT REDUCED



SAVING OF COPPER

NOTE

For values (e.g., Current Intensity) related to parameters not specified in the catalog tables (e.g., temperature values), refer to QWARE downloadable from our website www.teknomega.it.

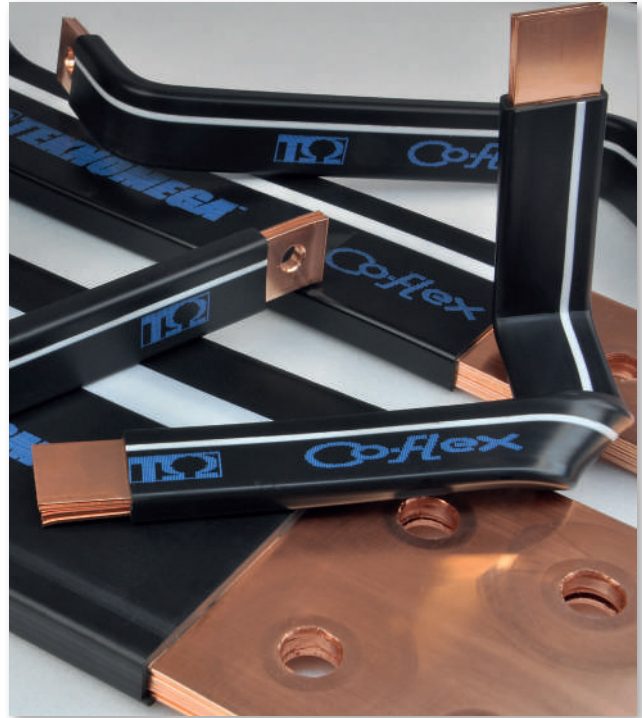
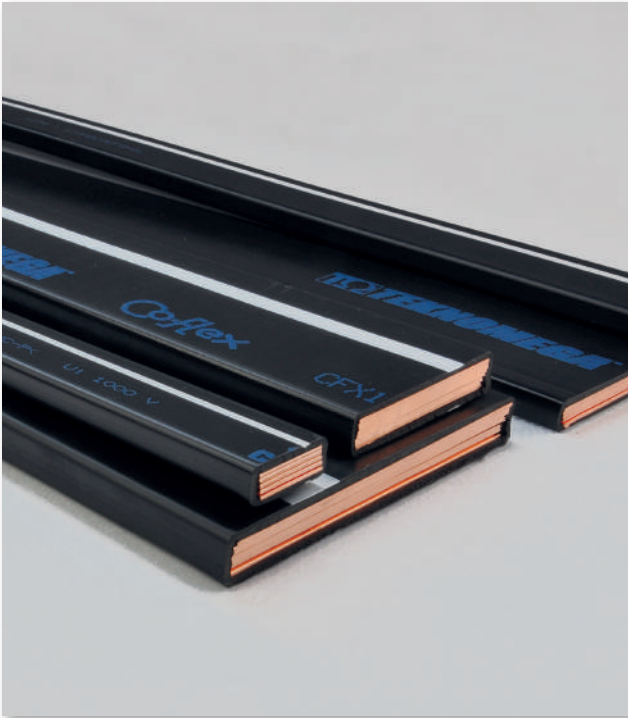

RANGE

Versions: COFLEX - COFLEX PLUS

Standard length: 2 - 3 m

Laminates width: 9 - 13 - 15,5 - 20 - 24 - 32 - 40 - 50 - 63 - 80 - 100 mm

Number of laminates: from 2 to 12, according to the bar's width

Cross section: from 20 to 1200 mm²

COFLEX ADDED VALUE

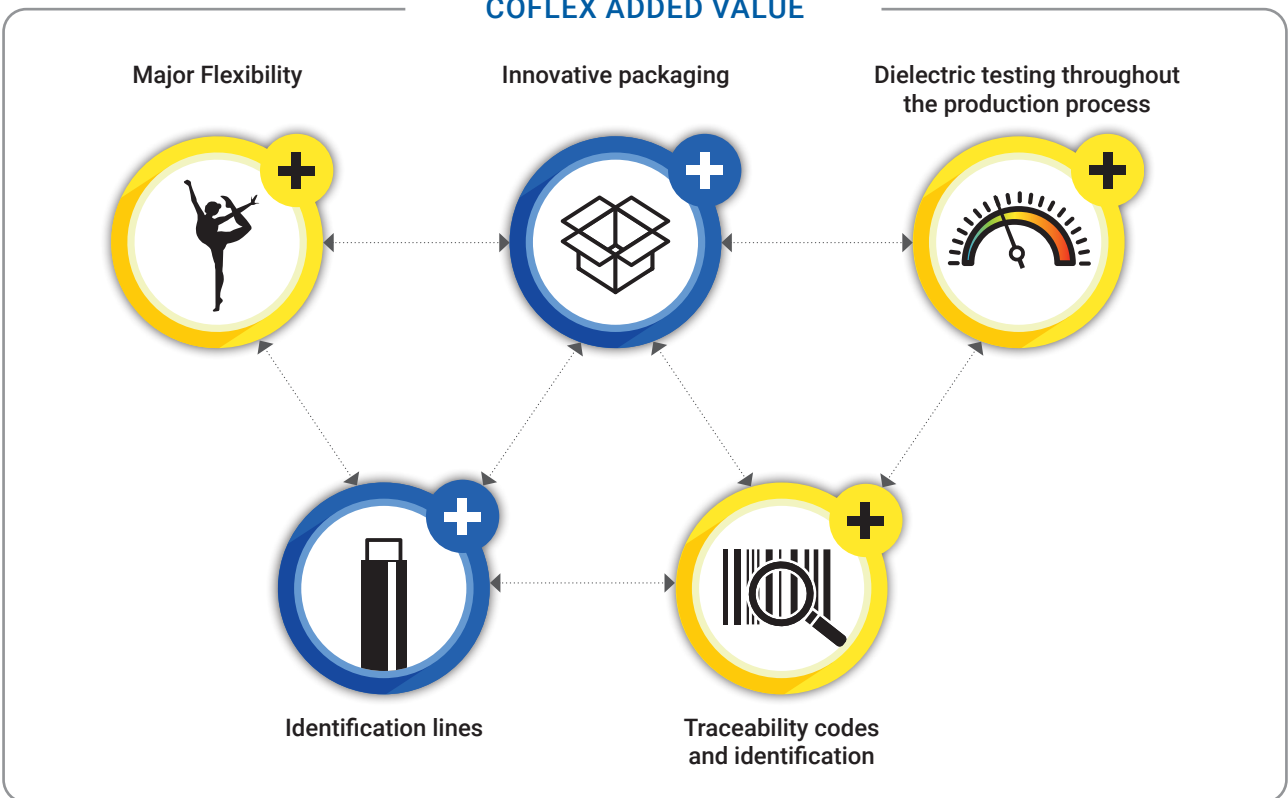



TECHNICAL CHARACTERISTICS

Conductor

Electrolytic copper:
Cu-ETP - EN 13599
Laminate thickness:
0.5 - 0.8 - 1 mm

Insulation

PVC compound
Black color with a white line
Self-extinguishing: UL 94-V0
Thickness: 2 mm
Dielectric rigidity: 20 kV / mm
Class II according to Par. 8.4.4 IEC 61439-1
Recyclable

Finished product

Rated voltage:
1000 V AC / 1500 V DC
Working temperature:
-40 °C ÷ +105 °C



CHOICE $I_n - \Delta T$

I_n = Rated current A
 ΔT = Temperature rise °C
 T_f = Working temperature °C
 T_a = Room temperature °C

EXAMPLE:

If the final operating temperature is 90 °C, consider the value corresponding to a thermal rise of 55 °C, as the following relationship applies: $T_f = T_a + \Delta T$
90 °C = 35 °C + 55 °C

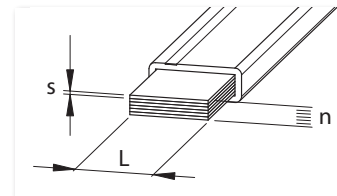

REFERENCE EXAMPLE

CFX 4X20X1
Laminate number: $n = 4$
Laminates width: $L = 20$ mm
Laminate thickness: $s = 1$ mm

DERATING COEFFICIENT FOR THE USE OF BARS IN PARALLEL

Bar width (L)	Number of bars in parallel		
	//	///	// //
L < 63 mm	1.72	2.25	2.93
63 mm ≤ L < 100 mm	1.65	2.12	2.7
L = 100 mm	1.6	2.02	2.4

UPON REQUEST: Tinned copper laminates.

2 METERS LENGTH

Table of ampacity (A) based on temperature rise ΔT as per IEC 61439-1
Reference room temperature 35°C

L	Code	Reference		Weight (kg)	Sect. (mm ²)	Temperature rise ΔT			
						35 °C	45 °C	55 °C	70 °C
						Rated Intensity In (A)			
9	CFX1005	CFX 3X9X0,8	6	0,5	21,6	134	154	172	196
	CFX1020	CFX 6X9X0,8	6	0,9	43,2	201	230	257	292
	CFX1021	CFX 9X9X0,8	4	1,3	64,8	258	296	330	375
13	CFX1022	CFX 3X13X0,5	6	0,45	19,5	134	154	172	195
	CFX1023	CFX 6X13X0,5	6	0,92	39	196	225	251	285
	CFX1024	CFX 10X13X0,5	4	1,41	65	263	302	337	383
15,5	CFX1025	CFX 2X15,5X0,8	6	0,68	24,8	158	181	202	230
	CFX1035	CFX 4X15,5X0,8	6	1,14	49,6	230	264	295	335
	CFX1045	CFX 6X15,5X0,8	6	1,6	74,4	290	333	371	422
20	CFX1050	CFX 10X15,5X0,8	4	2,52	124	394	452	504	573
	CFX1055	CFX 2X20X1	6	1	40	215	246	275	312
	CFX1060	CFX 3X20X1	6	1,37	60	267	307	342	389
24	CFX1065	CFX 4X20X1	6	1,74	80	314	360	402	457
	CFX1070	CFX 5X20X1	6	2,11	100	356	409	456	519
	CFX1075	CFX 6X20X1	6	2,47	120	396	454	506	576
28	CFX1076	CFX 8X20X1	4	3,21	160	469	538	600	683
	CFX1080	CFX 10X20X1	4	3,94	200	537	616	687	782
	CFX1085	CFX 2X24X1	4	1,19	48	247	283	315	359
32	CFX1090	CFX 3X24X1	4	1,63	72	307	352	392	446
	CFX1095	CFX 4X24X1	3	2,07	96	359	412	460	523
	CFX1100	CFX 5X24X1	3	2,51	120	407	467	521	592
36	CFX1105	CFX 6X24X1	3	2,94	144	451	518	578	657
	CFX1110	CFX 8X24X1	2	3,82	192	533	612	683	777
	CFX1115	CFX 10X24X1	2	4,7	240	609	699	779	887
40	CFX1120	CFX 2X32X1	4	1,56	64	309	354	395	449
	CFX1125	CFX 3X32X1	4	2,14	96	383	439	489	557
	CFX1130	CFX 4X32X1	3	2,72	128	447	513	572	650
44	CFX1135	CFX 5X32X1	3	3,3	160	505	579	646	735
	CFX1140	CFX 6X32X1	3	3,89	192	559	641	715	813
	CFX1145	CFX 8X32X1	2	5,05	256	657	754	841	957
48	CFX1150	CFX 10X32X1	2	6,21	320	746	857	955	1088
	CFX1155	CFX 2X40X1	4	1,93	80	369	423	471	536
	CFX1160	CFX 3X40X1	4	2,66	120	456	523	583	664
52	CFX1165	CFX 4X40X1	3	3,38	160	532	610	680	774
	CFX1170	CFX 5X40X1	3	4,1	200	599	688	767	873
	CFX1175	CFX 6X40X1	3	4,83	240	662	759	847	964
56	CFX1180	CFX 8X40X1	2	6,27	320	775	889	992	1129
	CFX1185	CFX 10X40X1	2	7,72	400	877	1007	1123	1278
	CFX1190	CFX 3X50X1	4	3,3	150	546	626	698	794
60	CFX1195	CFX 4X50X1	3	4,2	200	635	728	811	923
	CFX1200	CFX 5X50X1	3	5,1	250	714	819	913	1039
	CFX1205	CFX 6X50X1	3	6	300	786	902	1006	1145
64	CFX1210	CFX 8X50X1	2	7,8	400	916	1052	1173	1336
	CFX1215	CFX 10X50X1	2	9,61	500	1033	1186	1323	1507
	CFX1220	CFX 3X63X1	1	4,13	189	659	756	842	958
68	CFX1225	CFX 4X63X1	1	5,27	252	764	877	977	1112
	CFX1230	CFX 5X63X1	1	6,4	315	857	984	1097	1248
	CFX1235	CFX 6X63X1	1	7,53	378	942	1081	1205	1372
72	CFX1240	CFX 8X63X1	1	9,8	504	1093	1254	1399	1593
	CFX1245	CFX 10X63X1	1	12	630	1227	1409	1571	1790
	CFX1250	CFX 3X80X1	1	5,22	240	803	920	1026	1167
76	CFX1255	CFX 4X80X1	1	6,66	320	928	1064	1186	1350
	CFX1260	CFX 5X80X1	1	8,09	400	1038	1191	1328	1511
	CFX1265	CFX 6X80X1	1	9,53	480	1138	1305	1455	1657
80	CFX1270	CFX 8X80X1	1	12,4	640	1314	1508	1682	1916
	CFX1275	CFX 10X80X1	1	15,3	800	1468	1686	1881	2143
	CFX1280	CFX 4X100X1	1	8,3	400	1114	1277	1424	1620
84	CFX1285	CFX 5X100X1	1	10,1	500	1243	1426	1589	1809
	CFX1290	CFX 6X100X1	1	11,9	600	1358	1558	1738	1979
	CFX1295	CFX 8X100X1	1	15,5	800	1561	1792	1999	2277
88	CFX1300	CFX 10X100X1	1	19,1	1000	1739	1996	2227	2538
	CFX1305	CFX 12X100X1	1	22,6	1200	1899	2180	2433	2774

Items in stock. Other sizes available upon request.

3 METERS LENGTH

 Table of ampacity (A) based on temperature rise ΔT as per IEC 61439-1
 Reference room temperature 35°C

L	Code	Reference		Weight (kg)	Sect. (mm ²)	Temperature rise ΔT			
						35 °C	45 °C	55 °C	70 °C
						Rated Intensity In (A)			
9	CFX3005	CFX 3X9X0,8-3	1	0,75	21,6	134	154	172	196
	CFX3055	CFX 2X20X1-3	1	1,5	40	215	246	275	312
20	CFX3060	CFX 3X20X1-3	1	2,05	60	267	307	342	389
	CFX3065	CFX 4X20X1-3	1	2,61	80	314	360	402	457
	CFX3070	CFX 5X20X1-3	1	3,16	100	356	409	456	519
	CFX3085	CFX 2X24X1-3	1	1,78	48	247	283	315	359
24	CFX3090	CFX 3X24X1-3	1	2,44	72	307	352	392	446
	CFX3095	CFX 4X24X1-3	1	3,1	96	359	412	460	523
	CFX3100	CFX 5X24X1-3	1	3,76	120	407	467	521	592
	CFX3120	CFX 2X32X1-3	1	2,34	64	309	354	395	449
32	CFX3125	CFX 3X32X1-3	1	3,21	96	383	439	489	557
	CFX3135	CFX 5X32X1-3	1	4,95	160	505	579	646	735
	CFX3145	CFX 8X32X1-3	1	7,57	256	657	754	841	957
	CFX3170	CFX 5X40X1-3	1	6,15	200	599	688	767	873
40	CFX3185	CFX 10X40X1-3	1	11,58	400	877	1007	1123	1278
50	CFX3200	CFX 5X50X1-3	1	7,65	250	714	819	913	1039

Items in stock. Other sizes available upon request.



COFLEX is designed to be manufactured as well in a high performance version, COFLEX PLUS. COFLEX PLUS is made from tin-plated electrolytic copper laminates and insulated with a new high-performance technopolymer. COFLEX PLUS is halogen free, flame resistant and grants low smoke emission. A unique solution to increase the reliability of your electrical connection, and the safety of electrical equipment at the same time.

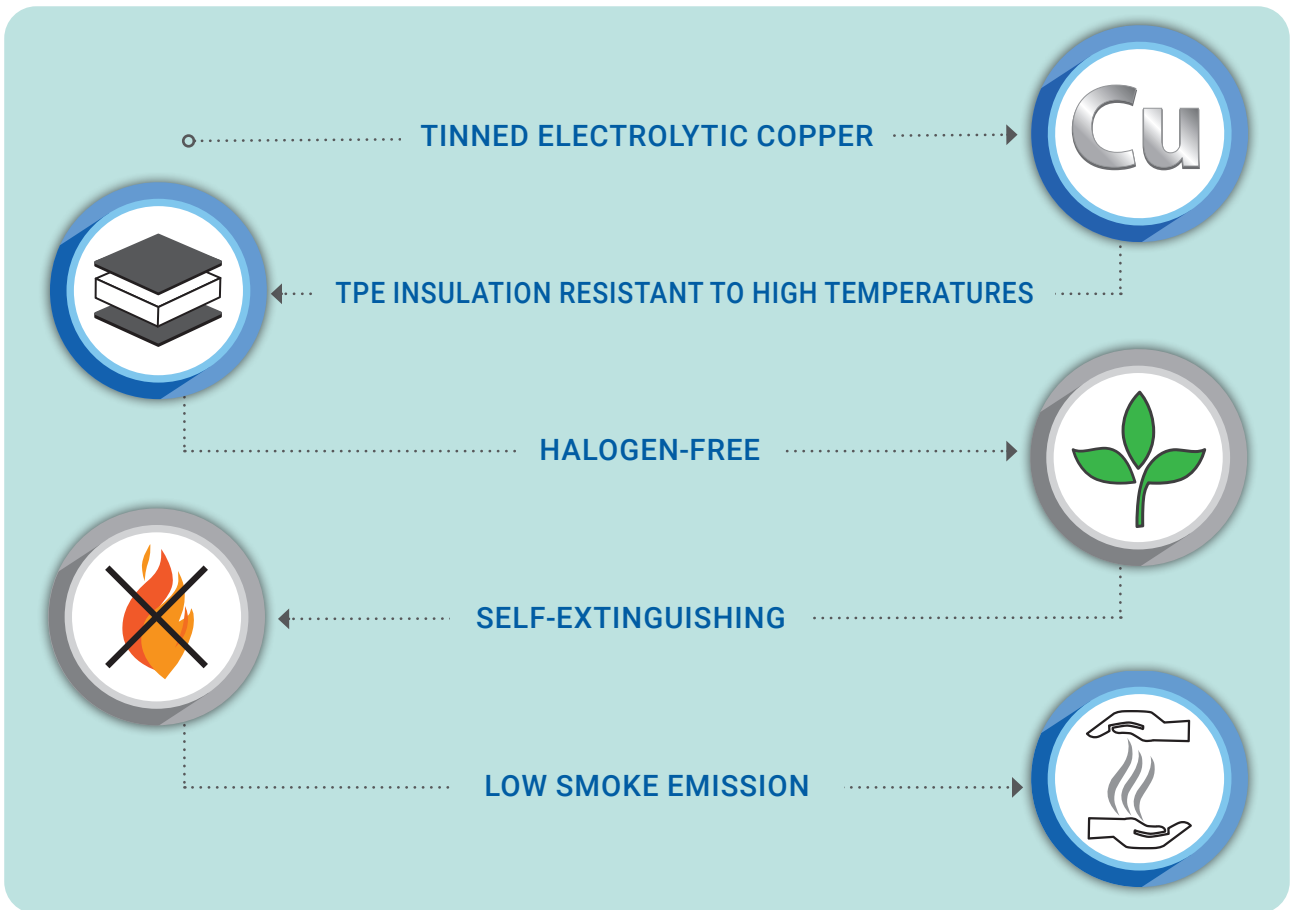



TECHNICAL CHARACTERISTICS

Conductor

Tinned electrolytic copper:
Cu-ETP - EN 13599
Laminate thickness:
0.5 - 0.8 - 1 mm



Insulation

TPE compound
Black color with a light blue line
Low smoke emission
Self-extinguishing: UL 94-V0
Halogen free
Thickness: 1.9 mm
Dielectric rigidity: 20 kV / mm
Class II according to Par. 8.4.4 IEC 61439-1
Recyclable

Finished product

Rated voltage:
1000 V AC / 1500 V DC
Working temperature:

-40 °C ÷ +140 °C

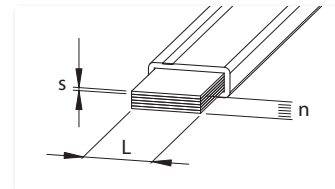

CHOICE $I_n - \Delta T$

I_n = Rated current A
 ΔT = Temperature rise °C
 T_f = Working temperature °C
 T_a = Room temperature °C

EXAMPLE:

If the final operating temperature is 90 °C, consider the value corresponding to a thermal rise of 55 °C, as the following relationship applies: $T_f = T_a + \Delta T$
90 °C = 35 °C + 55 °C

REFERENCE EXAMPLE

CFP 4X20X1
Laminate number: $n = 4$
Laminates width: $L = 20$ mm
Laminate thickness: $s = 1$ mm

DERATING COEFFICIENT FOR THE USE OF BARS IN PARALLEL

Bar width (L)	Number of bars in parallel		
	//	///	// //
L < 63 mm	1.72	2.25	2.93
63 mm ≤ L < 100 mm	1.65	2.12	2.7
L = 100 mm	1.6	2.02	2.4

UPON REQUEST: Red copper laminates.

2 METERS LENGTH

Table of ampacity (A) based on temperature rise ΔT as per IEC 61439-1
Reference room temperature 35°C

L	Code	Reference		Weight (kg)	Sect. (mm ²)	Temperature rise ΔT			
						35 °C	55 °C	70 °C	105 °C
						Rated Intensity In (A)			
9	CFX5005	CFP 3X9X0,8	6	0,44	21,6	134	172	196	242
	CFX5020	CFP 6X9X0,8	6	0,83	43,2	201	257	292	361
	CFX5021	CFP 9X9X0,8	4	1,22	64,8	258	330	375	464
13	CFX5022	CFP 3X13X0,5	6	0,39	19,5	134	172	195	241
	CFX5023	CFP 6X13X0,5	6	0,84	39	196	251	285	353
	CFX5024	CFP 10X13X0,5	4	1,32	65	263	337	383	473
15,5	CFX5025	CFP 2X15,5X0,8	6	0,6	24,8	158	202	230	284
	CFX5035	CFP 4X15,5X0,8	6	1,05	49,6	230	295	335	414
	CFX5045	CFP 6X15,5X0,8	6	1,5	74,4	290	371	422	522
20	CFX5050	CFP 10X15,5X0,8	4	2,41	124	394	504	573	709
	CFX5055	CFP 2X20X1	6	0,9	40	215	275	312	386
	CFX5060	CFP 3X20X1	6	1,26	60	267	342	389	482
24	CFX5065	CFP 4X20X1	6	1,63	80	314	402	457	565
	CFX5070	CFP 5X20X1	6	2	100	356	456	519	641
	CFX5075	CFP 6X20X1	6	2,35	120	396	506	576	713
24	CFX5076	CFP 8X20X1	4	3,08	160	469	600	683	845
	CFX5080	CFP 10X20X1	4	3,81	200	537	687	782	968
	CFX5085	CFP 2X24X1	4	1,07	48	247	315	359	444
32	CFX5090	CFP 3X24X1	4	1,51	72	307	392	446	552
	CFX5095	CFP 4X24X1	3	1,95	96	359	460	523	647
	CFX5100	CFP 5X24X1	3	2,38	120	407	521	592	733
32	CFX5105	CFP 6X24X1	3	2,81	144	451	578	657	813
	CFX5110	CFP 8X24X1	2	3,68	192	533	683	777	961
	CFX5115	CFP 10X24X1	2	4,55	240	609	779	887	1098
40	CFX5120	CFP 2X32X1	4	1,42	64	309	395	449	555
	CFX5125	CFP 3X32X1	4	1,99	96	383	489	557	689
	CFX5130	CFP 4X32X1	3	2,57	128	447	572	650	805
40	CFX5135	CFP 5X32X1	3	3,14	160	505	646	735	910
	CFX5140	CFP 6X32X1	3	3,73	192	559	715	813	1007
	CFX5145	CFP 8X32X1	2	4,88	256	657	841	957	1185
50	CFX5150	CFP 10X32X1	2	6,03	320	746	955	1088	1347
	CFX5155	CFP 2X40X1	4	1,76	80	369	471	536	664
	CFX5160	CFP 3X40X1	4	2,48	120	456	583	664	821
50	CFX5165	CFP 4X40X1	3	3,2	160	532	680	774	958
	CFX5170	CFP 5X40X1	3	3,91	200	599	767	873	1080
	CFX5175	CFP 6X40X1	3	4,64	240	662	847	964	1193
63	CFX5180	CFP 8X40X1	2	6,07	320	775	992	1129	1399
	CFX5185	CFP 10X40X1	2	7,51	400	877	1123	1278	1585
	CFX5190	CFP 3X50X1	4	3,09	150	546	698	794	983
63	CFX5195	CFP 4X50X1	3	3,98	200	635	811	923	1143
	CFX5200	CFP 5X50X1	3	4,88	250	714	913	1039	1287
	CFX5205	CFP 6X50X1	3	5,77	300	786	1006	1145	1418
80	CFX5210	CFP 8X50X1	2	7,57	400	916	1173	1336	1656
	CFX5215	CFP 10X50X1	2	9,37	500	1033	1323	1507	1869
	CFX5220	CFP 3X63X1	1	3,87	189	659	842	958	1187
80	CFX5225	CFP 4X63X1	1	5,01	252	764	977	1112	1377
	CFX5230	CFP 5X63X1	1	6,13	315	857	1097	1248	1547
	CFX5235	CFP 6X63X1	1	7,26	378	942	1205	1372	1701
100	CFX5240	CFP 8X63X1	1	9,52	504	1093	1399	1593	1977
	CFX5245	CFP 10X63X1	1	11,7	630	1227	1571	1790	2223
	CFX5250	CFP 3X80X1	1	4,9	240	803	1026	1167	1445
100	CFX5255	CFP 4X80X1	1	6,34	320	928	1186	1350	1673
	CFX5260	CFP 5X80X1	1	7,76	400	1038	1328	1511	1874
	CFX5265	CFP 6X80X1	1	9,2	480	1138	1455	1657	2056
100	CFX5270	CFP 8X80X1	1	12,1	640	1314	1682	1916	2378
	CFX5275	CFP 10X80X1	1	14,9	800	1468	1881	2143	2663
	CFX5280	CFP 4X100X1	1	7,9	400	1114	1424	1620	2009
100	CFX5285	CFP 5X100X1	1	9,7	500	1243	1589	1809	2244
	CFX5290	CFP 6X100X1	1	11,5	600	1358	1738	1979	2456
	CFX5295	CFP 8X100X1	1	15,1	800	1561	1999	2277	2829
100	CFX5300	CFP 10X100X1	1	18,7	1000	1739	2227	2538	3156
	CFX5305	CFP 12X100X1	1	22,2	1200	1899	2433	2774	3450

Items in stock. Other sizes available upon request.

Co-flex Color

The exclusive bi-color insulation finish (patented) improves connections aesthetics, making their identification easier.

The colored lines (standard white for COFLEX and light blue for COFLEX PLUS) on request might be realized with different colors in order to identify phases, or following the company color, or simply matching a desired aesthetic.

The lines can be customized in color as per customer request.



Co-flex Packaging

A bespoke packaging that overcomes the fragility of traditional packaging with elegance and care (patented).

Made in pressed carton with high rigidity, prevents the bars from their typical flexing and supports them in any leaning position, making easier any handling to the working table.

It can be stored both horizontally and vertically even in a small space, thanks to its rectangular shape.



PREFORMED FLEXIBLE BARS AS PER DRAWING

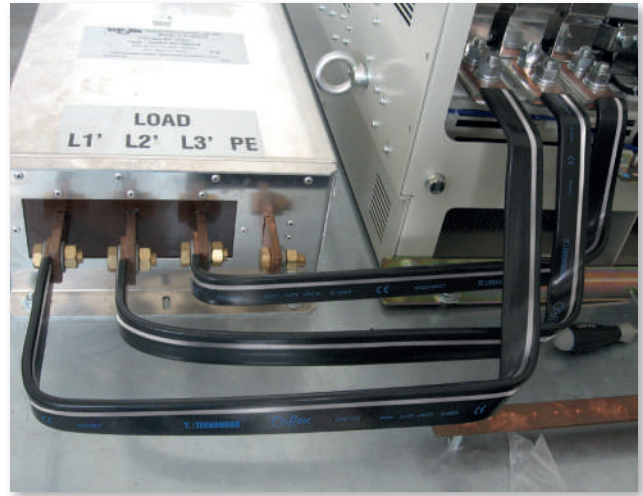
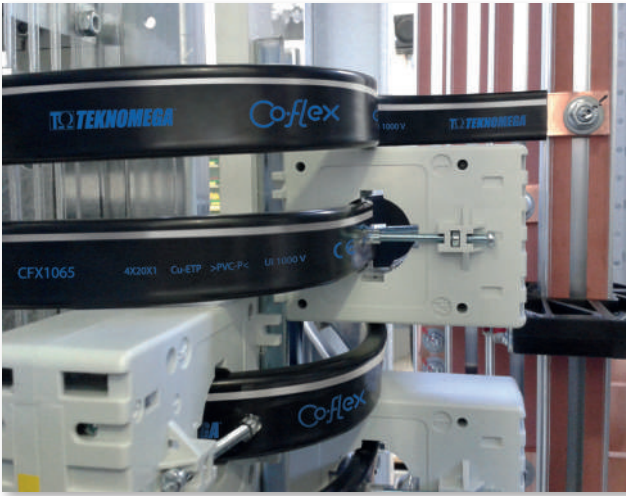

TEKNO MEGA have the capabilities to manufacture COFLEX INSULATED FLEXIBLE BARS bent and punched as per the customer's specific requirements. This is convenient in the event of a "series" of production of "standard" electric panel boards and/or equipment.

The use of CUSTOM PREFORMED INSULATED FLEXIBLE BARS makes it possible to optimize the wiring time and to eliminate excessive waste material.

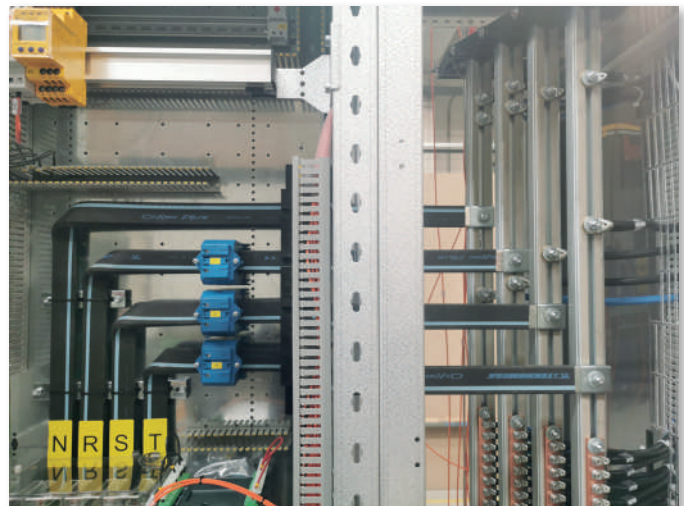
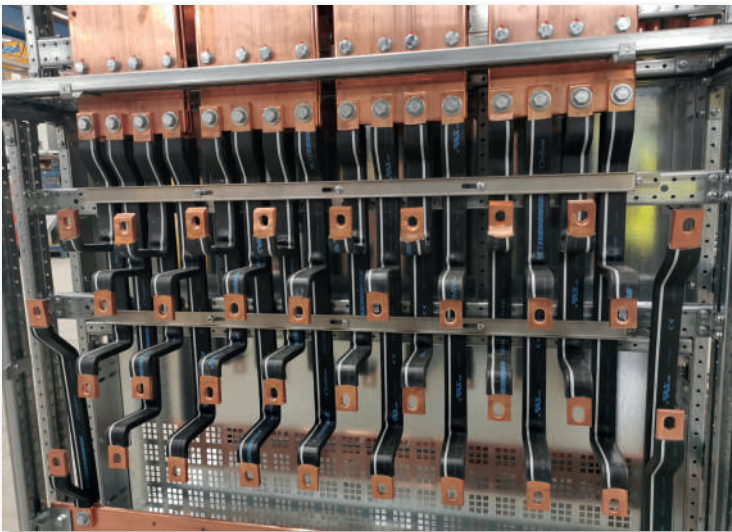

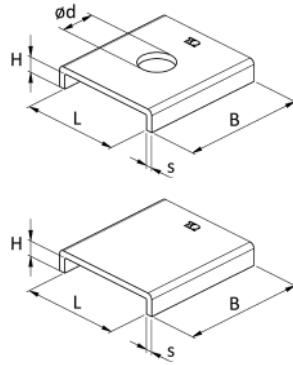

TECHNICAL CHARACTERISTICS

Material: S235JR steel
Finishing: Electrogalvanized steel

L = see laminates width

ADVANTAGES

Constraint of laminate
 Surface of connection with uniform pressure
 Increased mechanical strength of the fastener

FIXING PLATES FOR FLEXIBLE BARS

Code	Reference		L (mm)	H (mm)	B (mm)	s (mm)	ød (mm)	No. of laminate equal to:
PBF1060	PBF 3X20-M6	10	20	2,8	25	1,6	7	3
PBF1065	PBF 4X20-M8	10	20	3,8	25	1,6	9	4, 5, 6, 8, 10
PBF1090	PBF 3X24-M8	10	24	2,8	32	1,6	9	3, 4
PBF1100	BF 5X24-M10	10	24	4,8	32	2	11	5, 6, 8, 10
PBF1125	BF 3X32-M10	10	32	2,8	40	2	11	3, 4, 5
PBF1140	BF 6X32-M12	10	32	5,8	40	2	13	6, 8, 10
PBF1165	BF 4X40-M12	10	40	3,8	40	2	13	4, 5, 6
PBF1180	BF 8X40-80	4	40	7,8	80	2,5	without hole	8, 10
PBF1195	BF 4X50-40	4	50	3,8	40	2	without hole	4, 5, 6
PBF1210	BF 8X50-80	4	50	7,8	80	2,5	without hole	8, 10
PBF1225	BF 4X63-40	4	63	3,8	40	2,5	without hole	4, 5, 6
PBF1240	BF 8X63-80	4	63	7,8	80	3	without hole	8, 10
PBF1255	BF 4X80-50	4	80	3,8	50	2,5	without hole	4, 5, 6
PBF1270	BF 8X80-100	4	80	7,8	100	3	without hole	8, 10

Universal support with Ω FLAT FOR COFLEX FLEXIBLE BARS, see p. 54

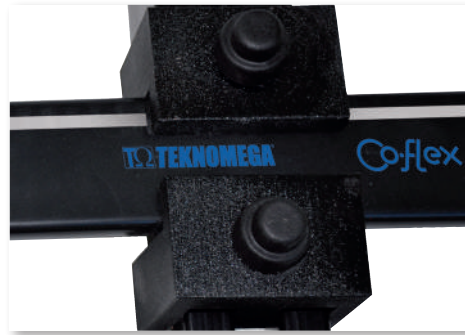
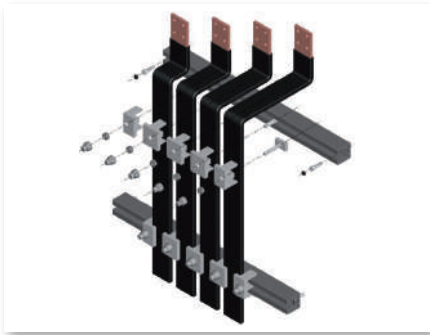

Simple support with spacer

APPLICATIONS and ADVANTAGES

- for use with insulated flexible bars up to 32x10x1.
- possibility to fit up to 4 flexible bars.
- fixing to the panel board structure by means of screw (not supplied) to be inserted at the base of the spacer
- Accurate and ordered fitting inside the panel board.
- Optimal heat dissipation thanks to the correct spacing between bar and bar

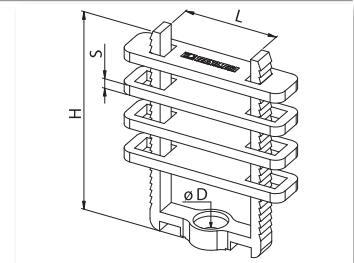
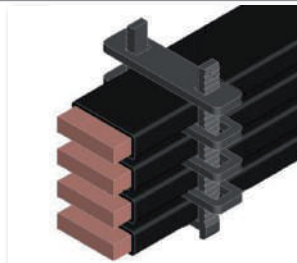

TECHNICAL CHARACTERISTICS

Material: Polyamide 6.6 reinforced with 30% fiberglass

Color: black

Self-extinguishing: UL 94-V0

Working temperature: -40 °C ÷ +140 °C

SPACER AND OVERLAPPING SUPPORT

Code	Reference		Sect. max COFLEX	H (mm)	L (mm)	S (mm)	øD (mm)
DZP3000	DZP BFX32	10	32 x 10 x 1	83	38	4	7

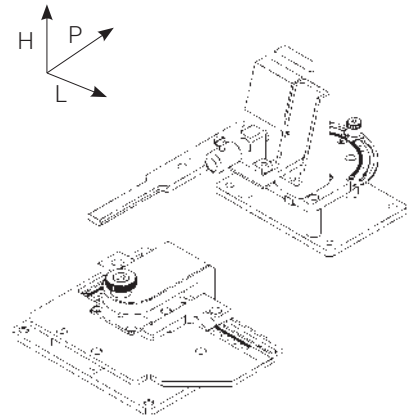

Simple and intuitive in their utilisation, they enable easy bending and drilling operations. Equipped with adjustment devices that ensure dimensional consistency of standard parts.

APPLICATION ADVANTAGES

The simplicity of the tools ensures they are safe and easy to use.

- fast and accurate processing
- no need for an external power supply
- easy to carry out work "on site"
- easy to fit on a workbench

Hand tool to drill insulated flexible bars

It allows optimal drilling of the terminal intended to the connection, without burrs or deformation of the individual copper laminates.

- for holes Ø 6.5 – Ø 8.5 - Ø 10.5 - Ø 12.5
- used to drill one or more holes on the bar
- Can be used on laminate ranging from 20mm to 120mm width
- Quick dies change for the various hole diameters
- Can be used with column or hand drilling tool.

Hand tool for bending and twisting insulated flexible bars

Allows bars to be machined into the appropriate shapes to optimize the lengths and overall dimensions of the connections.

Bending:

- Can be used on flexible bars up to 120x10x1 cross-sections
- Quick flexible bar tightening
- Goniometer to set the bending angle
- Blocking for repeated work on the same bending angle
- No damage to the insulation
- Little effort required thanks to the lever

Twisting:

- Can be used on flexible bars up to 120x10x1 cross-sections
- allows for a change of plan of the connection without damage to the insulation

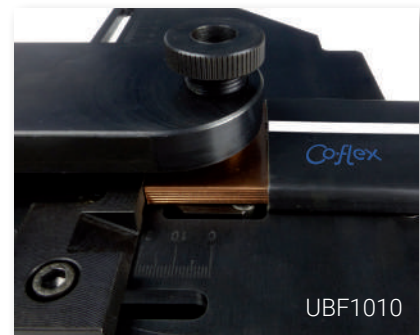
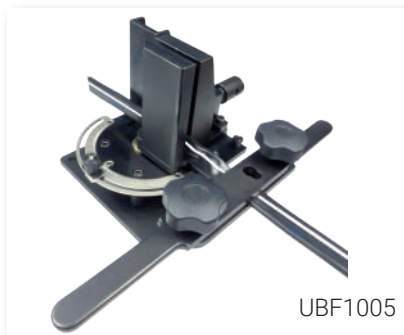
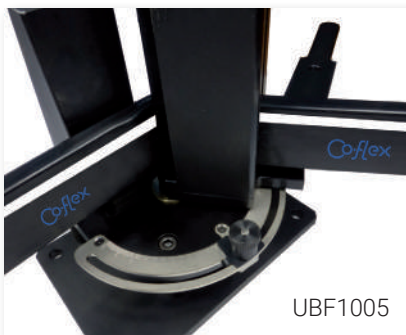

Code	Reference	Description		Weight (kg)	H (mm)	P (mm)	L (mm)
UBF1005	UPB-T-BFX	Bending + twisting	1	14.4	220	407	220
UBF1010	UFB-BFX	Hand tool to drill	1	7.1	65	175	240

The indicated dimensions refer to the machine block without lever

Video instructions: www.teknomega.com



J-LINK is a ready-to-use flexible prefabricated shunt made of tinned copper braid, coated with PVC insulation, which is highly resistant and self-extinguishing. J-LINK is the quickest and most convenient solution to create electrical connections from 125 to 630 A.

The connection terminals are made from pressed tinned copper tube, and their dimensions are designed because of the most popular box switches on the market.

The range includes the standard, PVC-insulated solution with white line and a maximum operating temperature of 105 °C and the Plus version, TPE-insulated, with blue scale and a maximum operating temperature of 140 °C.

The best alternative to cable connections and flexible bars

ADVANTAGES

- Ready-to-use connections: no preventive operation is required
- Extreme flexibility compared to a cable with similar cross-section
- Volume reduction inside the panel board
- Weight reduction
- Great time saving
- No cable to cut to measure
- No stripping of cable heads
- No lug to buy
- No crimping needed

EXCELLENT ELECTRICAL PARAMETERS

- Excellent electrical insulation
- Improved contact surface
- Improved ampacity at equal cross-sections compared to a cable and/or reduced cross-sections at the same rated current
- Reduction in heat due to the lack of crimped connections and to higher ampacities
- Excellent short-circuit resistance



File n° E300607
Certification pending

SOLUTIONS FOR THE SUPPORT OF J-LINK (References on p. 54)

NOTE

For values (e.g., Current Intensity) related to parameters not specified in the catalog tables (e.g., temperature values), refer to QWARE downloadable from our website www.teknomega.it.





High performance with J-LINK, equipped with PVC insulation, flame retardant and hyper flexible.
 J-LINK PLUS is recognizable from the light white line.
 The maximum continuous operation temperature is 105 °C.

RANGE

Cross-sections: from 25 mm² to 240 mm²
 Lengths: from 230 mm to 1030 mm
 Rated ampacity: from 125 A to 630 A

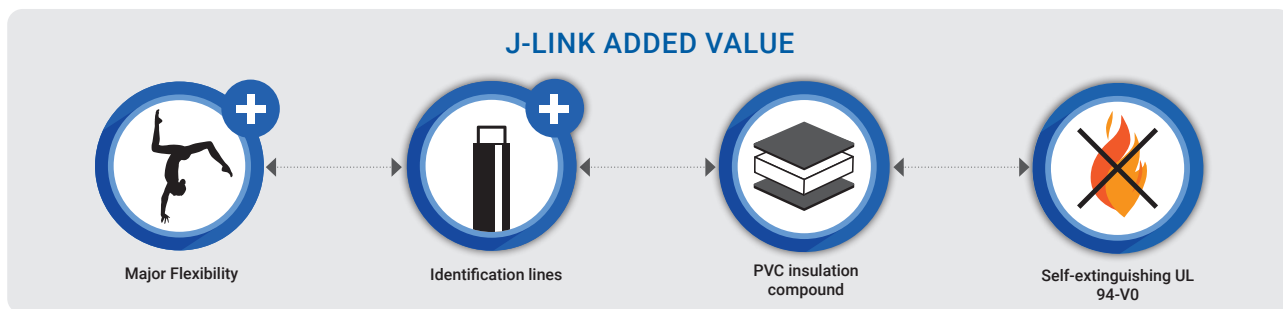

High performance with J-LINK PLUS, equipped with halogen-free, flame-retardant, low smoke-emitting and hyper flexible technopolymer insulation.
 J-LINK PLUS is recognizable from the light blue line.
 The maximum continuous operation temperature is 140 °C.

RANGE

Cross-sections: from 25 mm² to 240 mm²
 Lengths: from 230 mm to 1030 mm
 Rated ampacity: from 125 A to 630 A

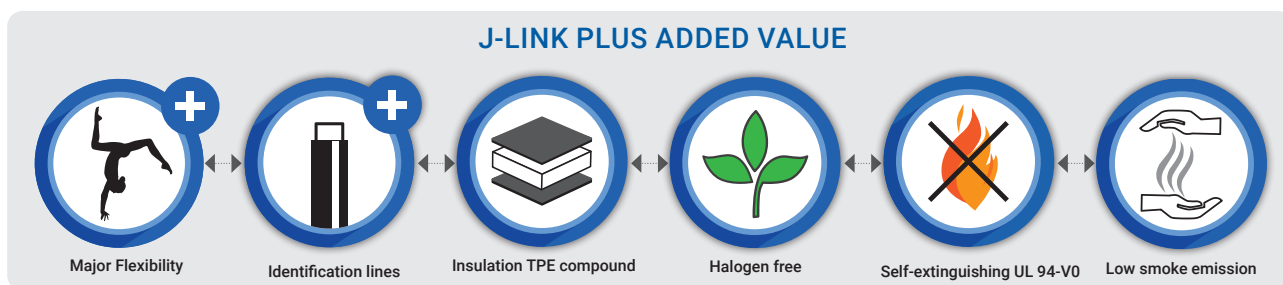

TECHNICAL CHARACTERISTICS

Insulation

PVC compound
 Black color with a white line
 Self-extinguishing: UL 94-V0
 Thickness: 1.9 mm
 Class II according to Par.
 8.4.4 IEC 61439-1
 Recyclable

Finished product

Dielectric rigidity: 20 kV/mm
 Rated voltage: 1000 V AC / 1500 V DC
 Working temperature:
 -40 °C ÷ + 105 °C

Conductor

Tinned electrolytic copper braid Cu-ETP 99.90%
 Standard wire: 0.20 mm
 Terminal in tinned copper tube

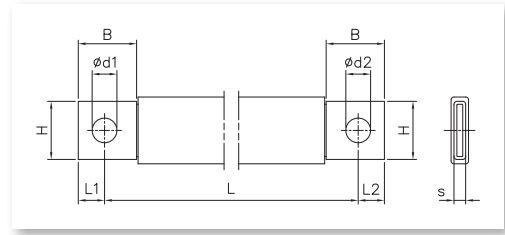

File n° E300607
 Certification pending

J-LINK Dimensional Table



Code	Reference		Weight (kg)	Sect. (mm ²)	Use with switch with	Dimensions (mm)								
						L	B	H	L1	L2	d1	d2	s	
JLK1000	JLK 25-230	10	0.08	25		230	20	20	7.5	8	8.5	10.5	4.3	
JLK1005	JLK 25-330	10	0.13	25		330	20	20	7.5	8	8.5	10.5	4.3	
JLK1010	JLK 25-430	10	0.17	25		430	20	20	7.5	8	8.5	10.5	4.3	
JLK1015	JLK 25-530	10	0.20	25		530	20	20	7.5	8	8.5	10.5	4.3	
JLK1020	JLK 25-630	10	0.24	25		630	20	20	7.5	8	8.5	10.5	4.3	
JLK1021	JLK 25-730	10	0.26	25		730	20	20	7.5	8	8.5	10.5	4.3	
JLK1022	JLK 25-830	10	0.30	25		830	20	20	7.5	8	8.5	10.5	4.3	
JLK1023	JLK 25-930	10	0.34	25		930	20	20	7.5	8	8.5	10.5	4.3	
JLK1024	JLK 25-1030	10	0.38	25		1030	20	20	7.5	8	8.5	10.5	4.3	
JLK1025	JLK 35-230	10	0.13	35			230	20	20	9	9.5	8.5	10.5	4.9
JLK1030	JLK 35-330	10	0.17	35	330		20	20	9	9.5	8.5	10.5	4.9	
JLK1035	JLK 35-430	10	0.22	35	430		20	20	9	9.5	8.5	10.5	4.9	
JLK1040	JLK35-530	10	0.27	35	530		20	20	9	9.5	8.5	10.5	4.9	
JLK1045	JLK 35-630	10	0.28	35	630		20	20	9	9.5	8.5	10.5	4.9	
JLK1046	JLK 35-730	10	0.34	35	730		20	20	9	9.5	8.5	10.5	4.9	
JLK1047	JLK 35-830	10	0.34	35	830		20	20	9	9.5	8.5	10.5	4.9	
JLK1048	JLK 35-930	10	0.37	35	930		20	20	9	9.5	8.5	10.5	4.9	
JLK1049	JLK 35-1030	10	0.40	35	1030		20	20	9	9.5	8.5	10.5	4.9	
JLK1050	JLK 50-230	10	0.16	50			230	20	20	9	9.5	8.5	10.5	5
JLK1055	JLK 50-330	10	0.20	50		330	20	20	9	9.5	8.5	10.5	5	
JLK1060	JLK 50-430	10	0.28	50		430	20	20	9	9.5	8.5	10.5	5	
JLK1065	JLK 50-530	10	0.36	50		530	20	20	9	9.5	8.5	10.5	5	
JLK1070	JLK 50-630	10	0.41	50		630	20	20	9	9.5	8.5	10.5	5	
JLK1071	JLK 50-730	10	0.47	50		730	20	20	9	9.5	8.5	10.5	5	
JLK1072	JLK 50-830	10	0.46	50		830	20	20	9	9.5	8.5	10.5	5	
JLK1073	JLK 50-930	10	0.60	50		930	20	20	9	9.5	8.5	10.5	5	
JLK1074	JLK 50-1030	10	0.65	50		1030	20	20	9	9.5	8.5	10.5	5	
JLK1140	JLK 85-230	2	0.26	85			230	25	24	9.5	11	8.5	10.5	6.5
JLK1145	JLK 85-330	2	0.35	85	330		25	24	9.5	11	8.5	10.5	6.5	
JLK1150	JLK 85-430	2	0.44	85	430		25	24	9.5	11	8.5	10.5	6.5	
JLK1155	JLK 85-530	2	0.50	85	530		25	24	9.5	11	8.5	10.5	6.5	
JLK1160	JLK 85-630	2	0.60	85	630		25	24	9.5	11	8.5	10.5	6.5	
JLK1165	JLK 85-730	2	0.68	85	730		25	24	9.5	11	8.5	10.5	6.5	
JLK1170	JLK 85-830	2	0.76	85	830		25	24	9.5	11	8.5	10.5	6.5	
JLK1175	JLK 85-930	2	0.85	85	930		25	24	9.5	11	8.5	10.5	6.5	
JLK1180	JLK 85-1030	2	0.95	85	1030		25	24	9.5	11	8.5	10.5	6.5	
JLK1075	JLK 120-330	2	0.50	120			330	30	30	11	15	10.5	10.5	7.5
JLK1080	JLK 120-430	2	0.64	120		430	30	30	11	15	10.5	10.5	7.5	
JLK1085	JLK 120-530	2	0.72	120		530	30	30	11	15	10.5	10.5	7.5	
JLK1090	JLK 120-630	2	0.90	120		630	30	30	11	15	10.5	10.5	7.5	
JLK1095	JLK 120-730	2	1.06	120		730	30	30	11	15	10.5	10.5	7.5	
JLK1096	JLK 120-830	2	1.19	120		830	30	30	11	15	10.5	10.5	7.5	
JLK1097	JLK 120-930	2	1.33	120		930	30	30	11	15	10.5	10.5	7.5	
JLK1098	JLK 120-1030	2	1.47	120		1030	30	30	11	15	10.5	10.5	7.5	
JLK1100	JLK 240-330	2	0.94	240			330	35	32	16	16	12.5	10.5	12.5
JLK1105	JLK 240-430	2	1.16	240			430	35	32	16	16	12.5	10.5	12.5
JLK1110	JLK 240-530	2	1.40	240	530		35	32	16	16	12.5	10.5	12.5	
JLK1115	JLK 240-630	2	1.64	240	630		35	32	16	16	12.5	10.5	12.5	
JLK1120	JLK 240-730	2	1.97	240	730		35	32	16	16	12.5	10.5	12.5	
JLK1125	JLK 240-830	2	2.23	240	830		35	32	16	16	12.5	10.5	12.5	
JLK1130	JLK 240-930	2	2.48	240	930		35	32	16	16	12.5	10.5	12.5	
JLK1135	JLK 240-1030	2	2.72	240	1030		35	32	16	16	12.5	10.5	12.5	

Ampacity (A) table of Copper Bar based on the T temperature rise as per standard IEC 61439-1
Reference room temperature 35°C

J-LINK Ampacity Table

Sect. (mm ²)	Codes	Rated Intensity In (A) Temperature Rise ΔT			
		35 °C	45 °C	55 °C	70 °C
25	From JLK1000 to JLK1024	144	164	181	203
35	From JLK1025 to JLK1049	176	200	222	249
50	From JLK1050 to JLK1074	214	244	270	304
85	From JLK1140 to JLK1180	304	346	383	431
120	From JLK1075 to JLK1098	383	436	482	543
240	From JLK1100 to JLK1135	589	672	744	840

Derating coefficient for use of J-LINK in parallel

Sect. (mm ²)		
25	1.70	2.00
35	1.70	2.00
50	1.70	1.95
85	1.65	1.85
120	1.65	1.85
240	1.55	1.75

Comparison between the use of cable and J-LINK

In (A)	**Cable type N07-VK	J-LINK
	Section (mm ²)	
125	35	25
160	50 ÷ 70	25 ÷ 35
250	95 ÷ 120	50
350	150 ÷ 185	85
400	240	120
630	2 x 150	240

* Indicative data



Upon request J-LINK becomes J-LINK COLOR, to identify phases or to satisfy a personal or corporate aesthetic.

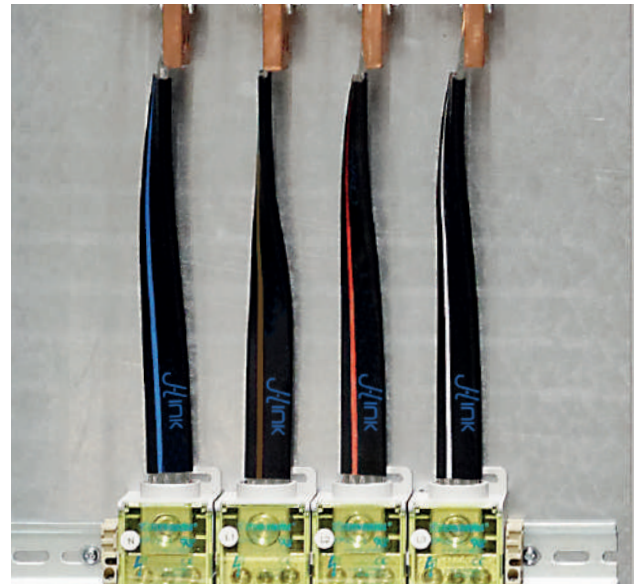

TECHNICAL CHARACTERISTICS

Insulation

TPE Compound
 Black color with a light blue
 Low smoke emission
 Self-extinguishing: UL 94-V0
 Halogen-free
 Thickness: 1.9 mm
 Class II according to Par.
 8.4.4 IEC 61439-1
 Recyclable

Finished product

Dielectric rigidity: 20 kV/mm
 Rated voltage: 1000 V AC / 1500 V DC
 Working temperature:

 -40 °C ÷ +140 °C

Conductor

Tinned electrolytic copper braid Cu-ETP 99.90%
 Standard wire: 0.20 mm
 Terminal in tinned copper tube

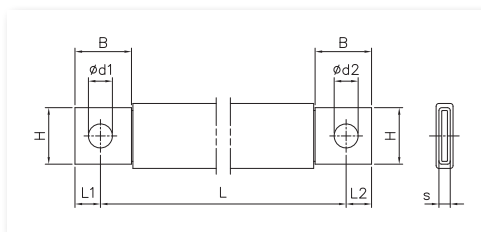

 File n° E300607
 Certification pending

J-LINK PLUS Dimensional Table

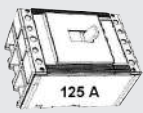
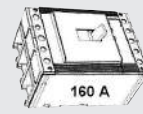
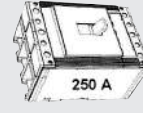
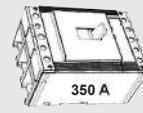
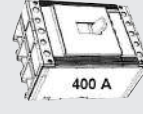
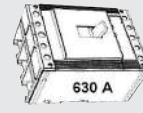

Code	Reference		Weight (kg)	Sect. (mm ²)	Use with switch with	Dimensions (mm)								
						L	B	H	L1	L2	d1	d2	s	
JLK5000	JLP 25-230	10	0.08	25		230	20	20	7.5	8	8.5	10.5	4.3	
JLK5005	JLP 25-330	10	0.13	25		330	20	20	7.5	8	8.5	10.5	4.3	
JLK5010	JLP 25-430	10	0.17	25		430	20	20	7.5	8	8.5	10.5	4.3	
JLK5015	JLP 25-530	10	0.20	25		530	20	20	7.5	8	8.5	10.5	4.3	
JLK5020	JLP 25-630	10	0.24	25		630	20	20	7.5	8	8.5	10.5	4.3	
JLK5021	JLP 25-730	10	0.26	25		730	20	20	7.5	8	8.5	10.5	4.3	
JLK5022	JLP 25-830	10	0.30	25		830	20	20	7.5	8	8.5	10.5	4.3	
JLK5023	JLP 25-930	10	0.34	25		930	20	20	7.5	8	8.5	10.5	4.3	
JLK5024	JLP 25-1030	10	0.38	25		1030	20	20	7.5	8	8.5	10.5	4.3	
JLK5025	JLP 35-230	10	0.13	35			230	20	20	9	9.5	8.5	10.5	4.9
JLK5030	JLP 35-330	10	0.17	35	330		20	20	9	9.5	8.5	10.5	4.9	
JLK5035	JLP 35-430	10	0.22	35	430		20	20	9	9.5	8.5	10.5	4.9	
JLK5040	JLP 35-530	10	0.26	35	530		20	20	9	9.5	8.5	10.5	4.9	
JLK5045	JLP 35-630	10	0.28	35	630		20	20	9	9.5	8.5	10.5	4.9	
JLK5046	JLP 35-730	10	0.30	35	730		20	20	9	9.5	8.5	10.5	4.9	
JLK5047	JLP 35-830	10	0.34	35	830		20	20	9	9.5	8.5	10.5	4.9	
JLK5048	JLP 35-930	10	0.37	35	930		20	20	9	9.5	8.5	10.5	4.9	
JLK5049	JLP 35-1030	10	0.40	35	1030		20	20	9	9.5	8.5	10.5	4.9	
JLK5050	JLP 50-230	10	0.16	50			230	20	20	9	9.5	8.5	10.5	5
JLK5055	JLP 50-330	10	0.22	50		330	20	20	9	9.5	8.5	10.5	5	
JLK5060	JLP 50-430	10	0.24	50		430	20	20	9	9.5	8.5	10.5	5	
JLK5065	JLP 50-530	10	0.34	50		530	20	20	9	9.5	8.5	10.5	5	
JLK5070	JLP 50-630	10	0.40	50		630	20	20	9	9.5	8.5	10.5	5	
JLK5071	JLP 50-730	10	0.43	50		730	20	20	9	9.5	8.5	10.5	5	
JLK5072	JLP 50-830	10	0.46	50		830	20	20	9	9.5	8.5	10.5	5	
JLK5073	JLP 50-930	10	0.48	50		930	20	20	9	9.5	8.5	10.5	5	
JLK5074	JLP 50-1030	10	0.50	50		1030	20	20	9	9.5	8.5	10.5	5	
JLK5140	JLP 85-230	2	0.26	85			230	25	24	9.5	11	8.5	10.5	6.5
JLK5145	JLP 85-330	2	0.35	85	330		25	24	9.5	11	8.5	10.5	6.5	
JLK5150	JLP 85-430	2	0.44	85	430		25	24	9.5	11	8.5	10.5	6.5	
JLK5155	JLP 85-530	2	0.50	85	530		25	24	9.5	11	8.5	10.5	6.5	
JLK5160	JLP 85-630	2	0.60	85	630		25	24	9.5	11	8.5	10.5	6.5	
JLK5165	JLP 85-730	2	0.68	85	730		25	24	9.5	11	8.5	10.5	6.5	
JLK5170	JLP 85-830	2	0.76	85	830		25	24	9.5	11	8.5	10.5	6.5	
JLK5175	JLP 85-930	2	0.85	85	930		25	24	9.5	11	8.5	10.5	6.5	
JLK5180	JLP 85-1030	2	0.95	85	1030		25	24	9.5	11	8.5	10.5	6.5	
JLK5075	JLP 120-330	2	0.53	120			330	30	30	11	15	10.5	10.5	7.5
JLK5080	JLP 120-430	2	0.65	120		430	30	30	11	15	10.5	10.5	7.5	
JLK5085	JLP 120-530	2	0.80	120		530	30	30	11	15	10.5	10.5	7.5	
JLK5090	JLP 120-630	2	0.95	120		630	30	30	11	15	10.5	10.5	7.5	
JLK5095	JLP 120-730	2	1.10	120		730	30	30	11	15	10.5	10.5	7.5	
JLK5096	JLP 120-830	2	1.25	120		830	30	30	11	15	10.5	10.5	7.5	
JLK5097	JLP 120-930	2	1.40	120		930	30	30	11	15	10.5	10.5	7.5	
JLK5098	JLP 120-1030	2	1.55	120		1030	30	30	11	15	10.5	10.5	7.5	
JLK5100	JLP 240-330	2	0.97	240			330	35	32	16	16	12.5	10.5	12.5
JLK5105	JLP 240-430	2	1.20	240			430	35	32	16	16	12.5	10.5	12.5
JLK5110	JLP 240-530	2	1.45	240	530		35	32	16	16	12.5	10.5	12.5	
JLK5115	JLP 240-630	2	1.74	240	630		35	32	16	16	12.5	10.5	12.5	
JLK5120	JLP 240-730	2	2.05	240	730		35	32	16	16	12.5	10.5	12.5	
JLK5125	JLP 240-830	2	2.25	240	830		35	32	16	16	12.5	10.5	12.5	
JLK5130	JLP 240-930	2	2.50	240	930		35	32	16	16	12.5	10.5	12.5	
JLK5135	JLP 240-1030	2	2.75	240	1030		35	32	16	16	12.5	10.5	12.5	

Ampacity (A) table of Copper Bar based on the T temperature rise as per standard IEC 61439-1
Reference room temperature 35°C

J-LINK PLUS Ampacity Table

Sect. (mm ²)	Codes	Rated Intensity In (A) Temperature Rise ΔT			
		35 °C	55 °C	70 °C	105 °C
25	From JLK5000 to JLK5024	144	181	203	245
35	From JLK5025 to JLK5049	176	222	249	301
50	From JLK5050 to JLK5074	214	270	304	367
85	From JLK5140 to JLK5180	304	383	431	522
120	From JLK5075 to JLK5098	383	482	543	658
240	From JLK5100 to JLK5135	589	744	840	1020

Derating coefficient for use of J-LINK PLUS in parallel

Sect. (mm ²)		
25	1.70	2.00
35	1.70	2.00
50	1.70	1.95
85	1.65	1.85
120	1.65	1.85
240	1.55	1.75

Comparison between the use of cable and J-LINK PLUS

In (A)	**Cable Type N07-VK	J-LINK
	Section (mm ²)	
125	35	25
160	50 ÷ 70	25 ÷ 35
250	95 ÷ 120	50
350	150 ÷ 185	85
400	240	120
630	2 x 150	240

** Indicative data

J-link Color

Upon request J- LINK PLUS becomes J-LINK COLOR, to identify phases or to satisfy a personal or corporate aesthetic.

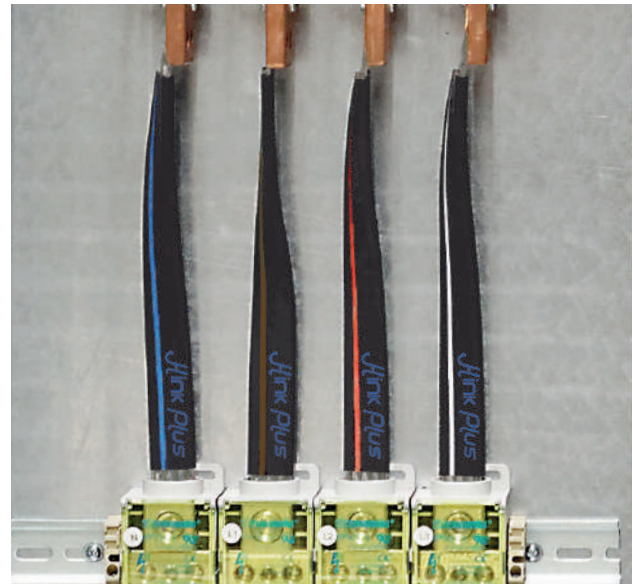

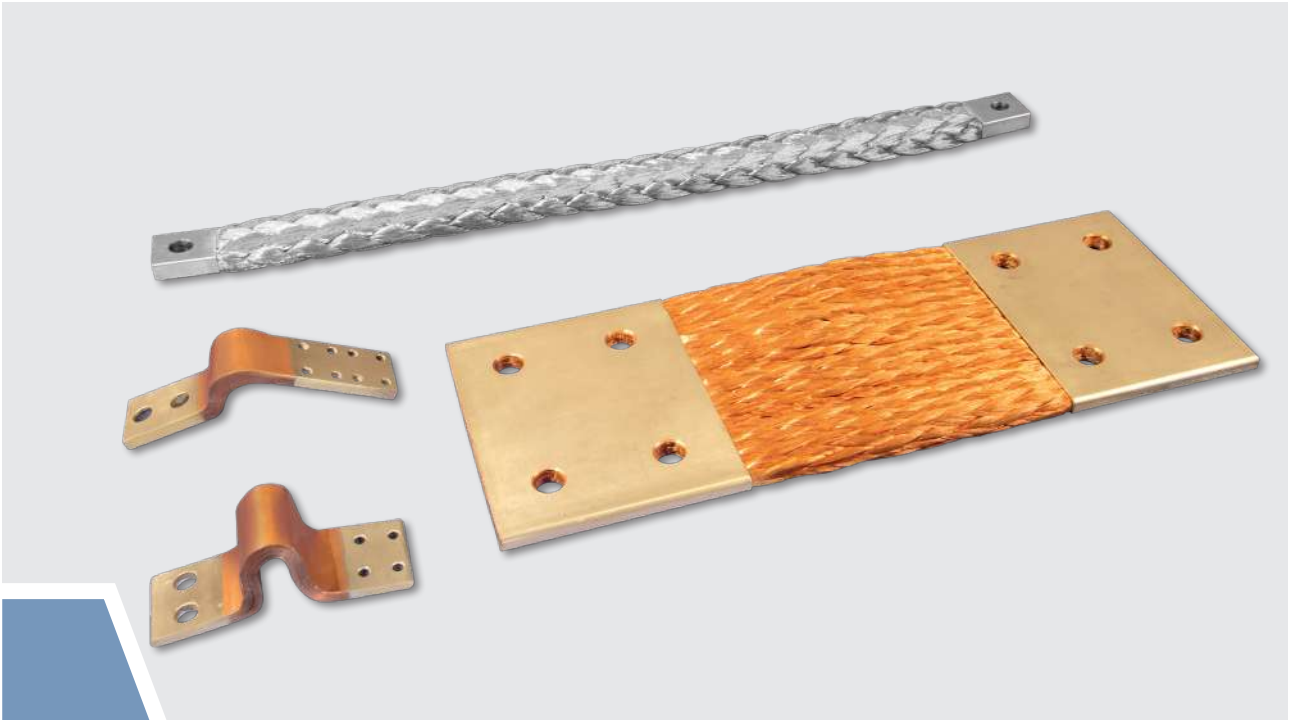

Braided power shunts

Braided power shunts

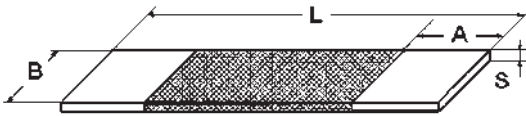

TECHNICAL CHARACTERISTICS

Material: red copper or tinned, Cu-ETP UNI EN 13602, or other material upon request

Standard wire: 0.05mm to 0.20mm or other sizes upon request
Terminals made in tinned copper tube, pressed at high density.

Punching upon request.
Make to order production
Insulation on demand

Laminated power shunts

Braided power shunts

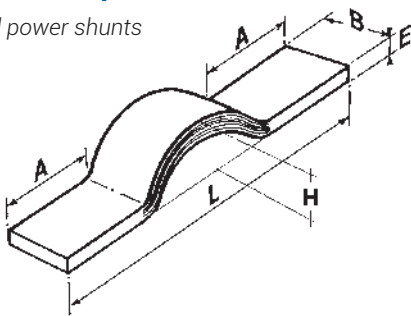

TECHNICAL CHARACTERISTICS

Terminal material: red or tinned copper, or other material upon request

Laminate thickness: starting from 0.1mm

Make to order production
Width from 20 to 200 mm
Terminal thickness from 3 to 20 mm
Section from 60 to 4000 mm²

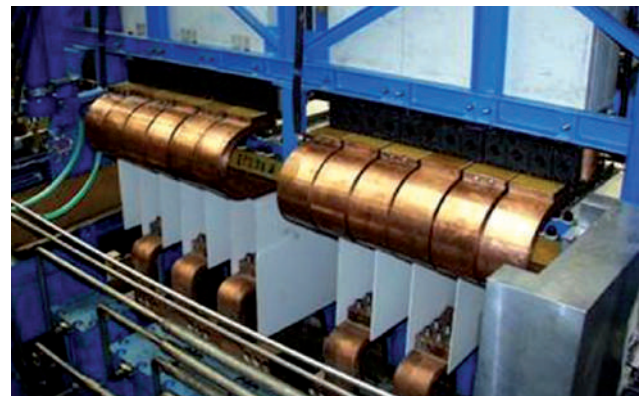

CONSTRUCTION CHARACTERISTICS AND DIMENSIONS

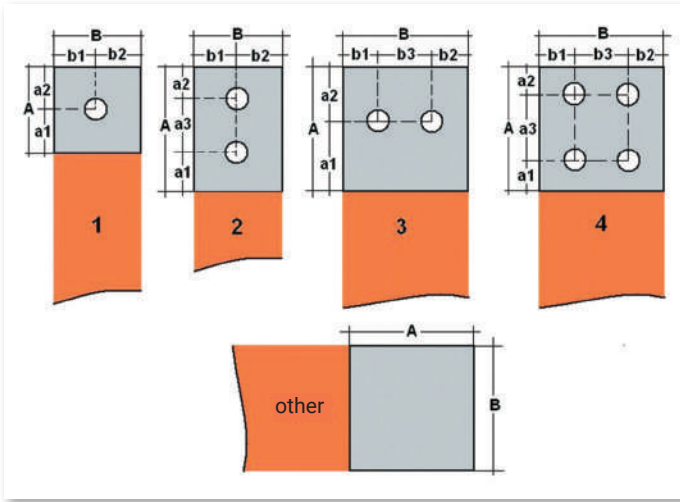

TERMINAL TYPE: _____

A = _____ mm

a1 = _____ mm

a2 = _____ mm

a3 = _____ mm

B = _____ mm

b1 = _____ mm

b2 = _____ mm

b3 = _____ mm

∅ holes = _____ mm No. _____ holes

Terminal thickness _____ mm

SHUNT IN

• Conductor type: Copper

red tinned

• Insulation yes no

Insulation type: _____

COPPER BRAID

Standard Wire dimension:

_____ mm

LAMINATE

Laminate number: _____

Laminate thickness: _____ mm

Nominal intensity: _____ A AC DC

Reference room temperature: _____ °C

Section: _____ mm²

Operating temperature: _____ °C

Total length: _____ mm

Note: This information is required to receive a quote.
Please, enclose drawing or sketch of the detail to produce.

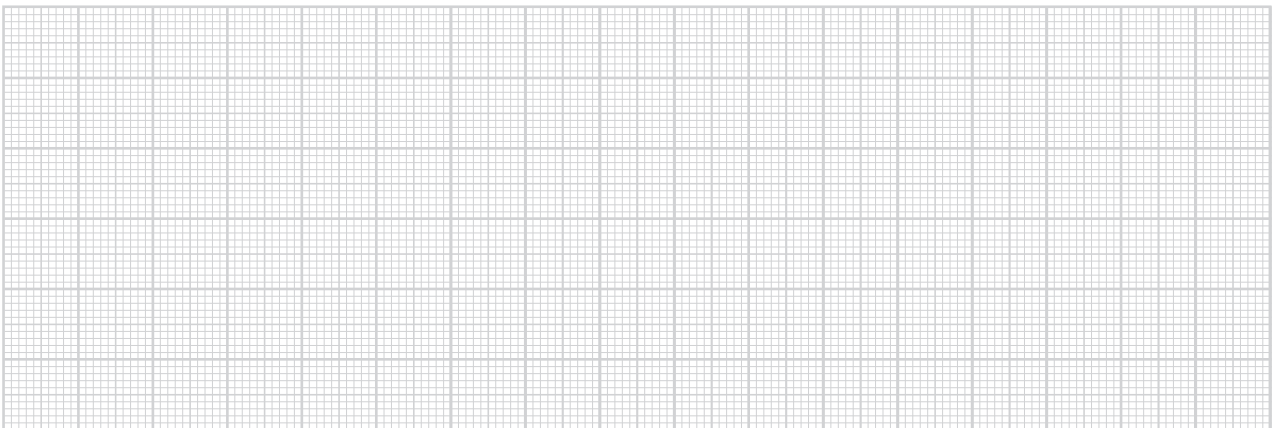

Other, specify: _____

Requested by:

Company: _____

Referent Mr. _____

Address: _____

City _____

Prov.: _____

Tel.: _____

Fax: _____

e-mail: _____

@ _____

Send by e-mail to info@teknomega.it
website: www.teknomega.it



The copper braid is used as a super flexible conductor for all electric connection requirements, including power, earthing and equipotential connections.

It results from the use of a number of standard wires with diameter of 0.20 mm, twined together to form a cord. More cords twined together can produce a small cross-sectioned braid or further secondary cords which, twined again, make it possible to get the desired cross-section.

Three typologies of copper braid:

- **FLAT**, made using the same process as in tubular braids, but flattening it between rollers to the desired dimensions. It is used for power, earthing and equipotential connections. In power applications, it makes flexible connections which easily compensate offsets between elements to be interconnected, and also provides excellent buffering of vibrations induced by, i.e., connection to a transformer. With the same cross-section, it can take a higher current density than cables or copper bars.

- **ROUND**, made from tightly interwoven cords until they become a solid round section. It is used for power and mass connections, and, when suitably insulated, as an alternative to the cables. In that case, compared to insulated cables, with the same cross-section, it allows more current density and, most of all, extraordinary flexibility.

- **TUBULAR**, made from small interwoven cords until they form a tubular structure, hollow inside. It is used as a protection sleeve for electric cables inserted inside of the braid, thus producing screens and protections against interferences and/or disturbances.



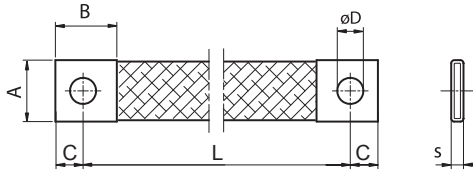

TECHNICAL CHARACTERISTICS

Material: tinned copper CU-ETP EN 13602
 Standard wire: \varnothing 0.20 mm
Resistivity: 0.0172 Ω mm²/m

FLAT TINNED COPPER EARTHING BRAIDS

Code	Reference		Weight (kg)	Intensity* (A)	Sect. (mm ²)	S (mm)	L (mm)	A (mm)	B (mm)	C (mm)	øD (mm)
TMS1000	TMS 6-150-6	10	0,010	57	6	2	150	10,5	10	6	6,5
TMS1005	TMS 6-200-6	10	0,013	57	6	2	200	10,5	10	6	6,5
TMS1010	TMS 10-150-8	10	0,021	86	10	2,1	150	17	22	9	8,5
TMS1015	TMS 10-200-8	10	0,025	86	10	2,1	200	17	22	9	8,5
TMS1020	TMS 10-250-8	10	0,029	86	10	2,1	250	17	22	9	8,5
TMS1025	TMS 10-300-8	10	0,033	86	10	2,1	300	17	22	9	8,5
TMS1030	TMS 16-100-8	10	0,023	115	16	2,6	100	17	22	9	8,5
TMS1035	TMS 16-150-8	10	0,030	115	16	2,6	150	17	22	9	8,5
TMS1040	TMS 16-200-8	10	0,037	115	16	2,6	200	17	22	9	8,5
TMS1045	TMS 16-250-8	10	0,046	115	16	2,6	250	17	22	9	8,5
TMS1050	TMS 16-300-8	10	0,054	115	16	2,6	300	17	22	9	8,5
TMS1055	TMS 25-150-10	10	0,048	152	25	2,8	150	21	22	11	10,5
TMS1060	TMS 25-200-10	10	0,059	152	25	2,8	200	21	22	11	10,5
TMS1065	TMS 25-250-10	10	0,072	152	25	2,8	250	21	22	11	10,5
TMS1070	TMS 25-300-10	10	0,084	152	25	2,8	300	21	22	11	10,5
TMS1075	TMS 35-150-10	10	0,061	192	35	3,6	150	21	22	11	10,5
TMS1080	TMS 35-200-10	10	0,077	192	35	3,6	200	21	22	11	10,5
TMS1085	TMS 35-250-10	10	0,097	192	35	3,6	250	21	22	11	10,5
TMS1090	TMS 35-300-10	10	0,110	192	35	3,6	300	21	22	11	10,5
TMS1095	TMS 50-100-10	10	0,080	244	50	4,8	100	25,5	25	12,5	10,5
TMS1100	TMS 50-150-10	10	0,095	244	50	4,8	150	25,5	25	12,5	10,5
TMS1105	TMS 50-200-10	10	0,129	244	50	4,8	200	25,5	25	12,5	10,5
TMS1110	TMS 50-250-10	10	0,143	244	50	4,8	250	25,5	25	12,5	10,5
TMS1115	TMS 50-300-10	10	0,179	244	50	4,8	300	25,5	25	12,5	10,5
TMS1120	TMS 75-200-10	10	0,185	323	75	5,5	200	30	30	15	10,5
TMS1125	TMS 75-250-10	10	0,225	323	75	5,5	250	30	30	15	10,5
TMS1130	TMS 75-300-10	10	0,265	323	75	5,5	300	30	30	15	10,5
TMS1135	TMS 100-200-12	10	0,250	365	100	6,5	200	30	30	15	12,5
TMS1140	TMS 100-250-12	10	0,300	365	100	6,5	250	30	30	15	12,5
TMS1145	TMS 100-300-12	10	0,375	365	100	6,5	300	30	30	15	12,5

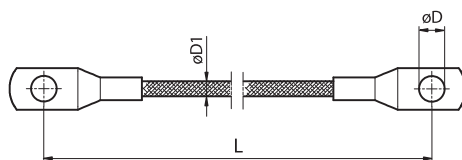

TECHNICAL CHARACTERISTICS

Material: tinned copper CU-ETP EN 13602
 Standard wire: \varnothing 0.20 mm
Resistivity: 0.0172 Ω mm²/m

ROUND TINNED COPPER EARTHING BRAIDS

Ring lugs as per DIN 46234

Code	Reference		Weight (kg)	Intensity* (A)	Sect. (mm ²)	øD1 (mm)	L (mm)	øD (mm)
TMT1200	TMT 6-150-6	10	0.0125	57	6	4	150	6.5
TMT1205	TMT 6-200-6	10	0.0154	57	6	4	200	6.5
TMT1210	TMT 10-300-6	10	0.0312	86	10	5	300	6.5

*Intensity calculated with a temperature rise of 35 °C and an ambient temperature of 35 °C.

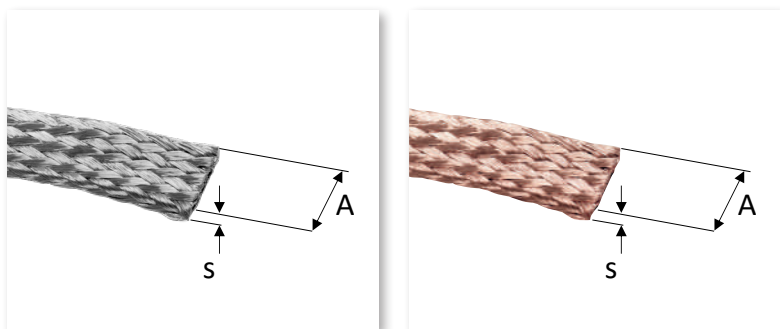

TECHNICAL CHARACTERISTICS

Material: red copper Cu-ETP UNI 5649-13602
 tinned copper Cu-ETP UNI 5649-13602
 Standard wire: \varnothing 0.20mm
Resistivity: 0.0172 $\Omega\text{mm}^2/\text{m}$

FLAT BRAIDS

Code	Reference	Code	Reference		Weight (kg/m)	Intensity* (A)	Sect. (mm ²)	S (mm)	A (mm)
TINNED COPPER		RED COPPER							
TPS1000	TPS 10-4	TPR1000	TPR 10-4	25 m	0.04	40	4	1.0	8.0
TPS1005	TPS 10-6	TPR1005	TPR 10-6	25 m	0.06	57	6	1.0	10.0
TPS1010	TPS 20-10	TPR1010	TPR 20-10	25 m	0.10	86	10	1.5	10.0
TPS1015	TPS 20-16	TPR1015	TPR 20-16	25 m	0.16	115	16	2.0	16.0
TPS1020	TPS 20-25	TPR1020	TPR 20-25	20 m	0.25	152	25	2.0	25.0
TPS1025	TPS 20-30	TPR1021	TPR 20-30	20 m	0.30	170	30	2.4	25.0
TPS1030	TPS 20-35	TPR1025	TPR 20-35	20 m	0.35	192	35	2.8	25.0
TPS1035	TPS 20-40	TPR1026	TPR 20-40	20 m	0.40	210	40	3.2	25.0
TPS1040	TPS 20-50	TPR1030	TPR 20-50	20 m	0.50	244	50	4.0	25.0
TPS1045	TPS 20-75	TPR1035	TPR 20-75	20 m	0.75	323	75	5.0	30.0
TPS1050	TPS 20-100	TPR1040	TPR 20-100	15 m	1.00	365	100	5.0	40.0
TPS1055	TPS 20-120	TPR1045	TPR 20-120	15 m	1.20	420	120	6.0	40.0

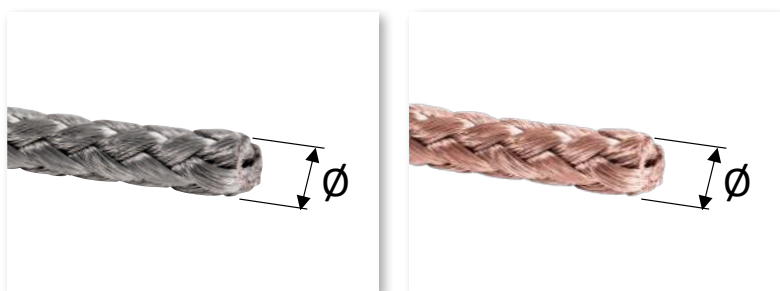

TECHNICAL CHARACTERISTICS

Material: red copper Cu-ETP UNI 5649-13602
 tinned copper Cu-ETP UNI 5649-13602
 Standard wire: \varnothing 0.20mm
Resistivity: 0.0172 $\Omega\text{mm}^2/\text{m}$

ROUND BRAIDS

Code	Reference	Code	Reference		Weight (kg/m)	Intensity* (A)	Sect. (mm ²)	\varnothing (mm)
TINNED COPPER		RED COPPER						
TTS1000	TTS 10-6	TTR1000	TTR 10-6	50 m	0.06	57	6	4.0
TTS1005	TTS 20-10	TTR1005	TTR 20-10	50 m	0.10	86	10	5.0
TTS1010	TTS 20-16	TTR1010	TTR 20-16	50 m	0.16	115	16	6.4
TTS1015	TTS 20-25	TTR1015	TTR 20-25	25 m	0.25	152	25	8.0
TTS1020	TTS 20-35	TTR1020	TTR 20-35	25 m	0.35	192	35	9.5
TTS1025	TTS 20-50	TTR1025	TTR 20-50	25 m	0.50	244	50	11.0
TTS1030	TTS 20-100	TTR1030	TTR 20-100	10 m	1.00	365	100	15.0

*Intensity calculated with a temperature rise of 35 °C and an ambient temperature of 35 °C.

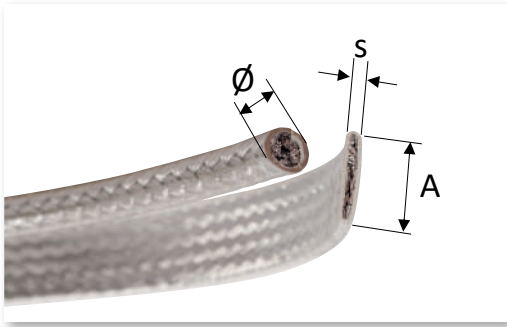

TECHNICAL CHARACTERISTICS

Material: Tinned copper Cu-ETP UNI EN 13602

Standard wire: Ø 0.20mm

Resistivity: 0.0172 Ωmm²/m
transparent PVC, thickness 1.5 mm

Electric insulation: 450V

Max. working temperature: -40 °C ÷ +80 °C

INSULATED BRAIDS IN TINNED COPPER - Flat

Code	Reference		Weight (kg/m)	Intensity* (A)	Section of conductor (mm ²)	S (mm)	A (mm)
TPI1000	TPI 20-16	20 m	0.20	115	16	4.5	19
TPI1005	TPI 20-25	20 m	0.30	152	25	5	28
TPI1010	TPI 20-35	20 m	0.40	192	35	6	28
TPI1015	TPI 20-50	20 m	0.55	244	50	6.3	33

INSULATED BRAIDS IN TINNED COPPER - Round

Code	Reference		Weight (kg/m)	Intensity* (A)	Section of conductor (mm ²)	Ø (mm)
TTI1000	TTI 20-16	50 m	0.18	115	16	9.5
TTI1005	TTI 20-25	25 m	0.27	152	25	10
TTI1010	TTI 20-35	25 m	0.4	192	35	12

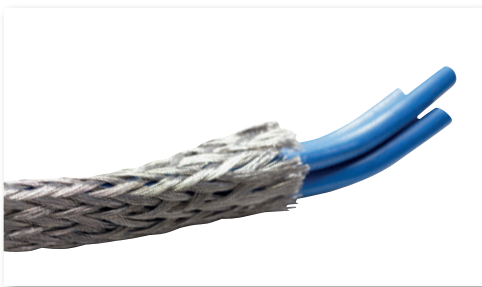

TECHNICAL CHARACTERISTICS

Material: Tinned copper Cu-ETP UNI EN 13602

Standard wire diameter: Ø 0.20 mm

Resistivity: 0.0172 Ωmm²/m

It is used as a protection sleeve for electric cables inserted inside of the braid, thus producing screens and protections against interferences and/or disturbances.

TUBULAR BRAIDS IN TINNED COPPER

Code	Reference		Weight (kg/m)	Ø nom. (mm)	Ø max (mm)
TSC1000	TSC 4	50 m	0.03	5	10
TSC1005	TSC 10	50 m	0.06	10	20
TSC1010	TSC 16	50 m	0.20	20	40
TSC1015	TSC 25	25 m	0.27	25	50
TSC1020	TSC 35	25 m	0.34	30	60
TSC1025	TSC 50	25 m	0.41	35	70

*Intensity calculated with a temperature rise of 35 °C and an ambient temperature of 35 °C.

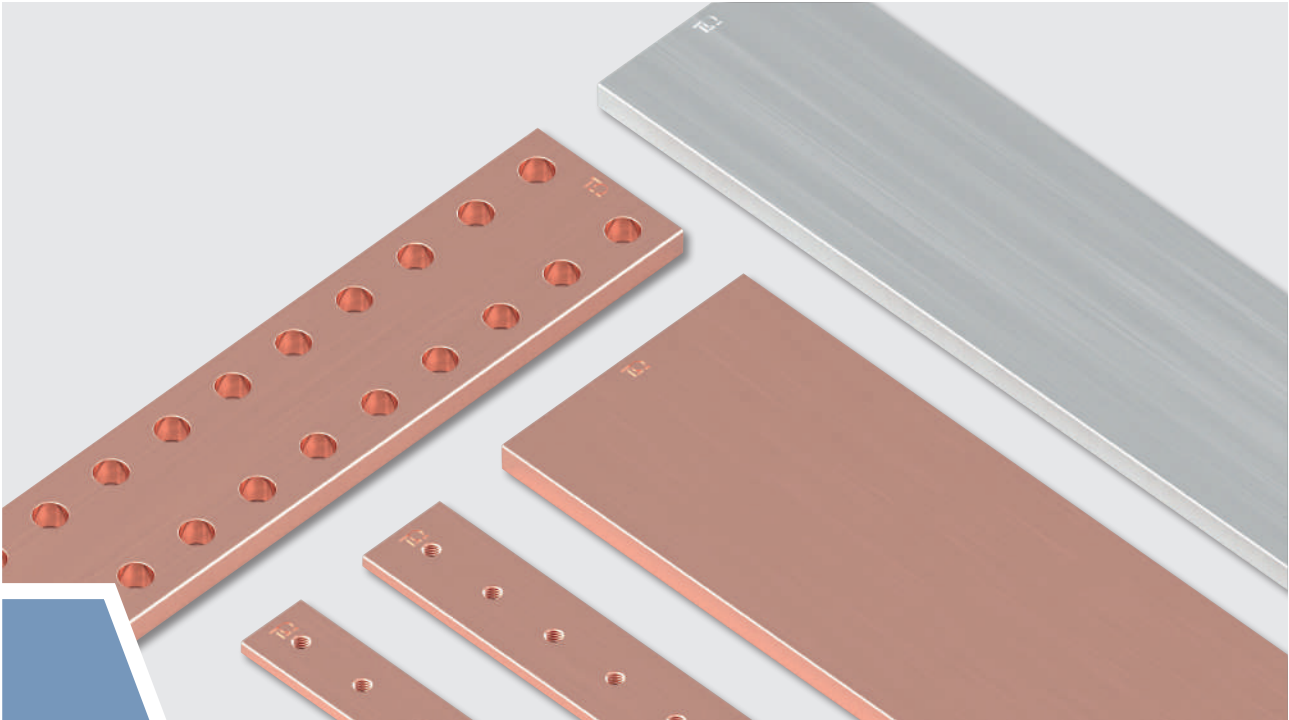

TEKNOMEGA supplies rigid bars, in copper and aluminum, to make distribution and power connections within electrical panels.

TEKNOMEGA can make custom bars, based on customer requirements, in red or tinned copper, aluminum, nickel-plated or galvanized, with specific lengths and drilling/threading pitches.

TECHNICAL CHARACTERISTICS

Copper bars

- Electrolytic copper Cu-ETP 99.90%
- Rounded corners
- Resistivity: 0.0172 $\Omega\text{mm}^2/\text{m}$
- Density: 8.9 kg/dm^3

Aluminium bars:

- Aluminium type EN-AW 1050 A
- Rounded corners
- Resistivity: 0.0265 $\Omega\text{mm}^2/\text{m}$
- Density: 2.7 kg/dm^3

ADVANTAGES

Prepunched and threaded copper bars

- Ready to use
- No need for punching tools
- Wiring time savings

Solid aluminium bars

- When compared to a copper bar with the same cross-section there is a significant weight saving, up to 70% less, with an ampacity reduction of about 30%.
- Significant cost saving advantages due to the different cost of the raw material and, especially, the great difference in the weight/volume ratio.

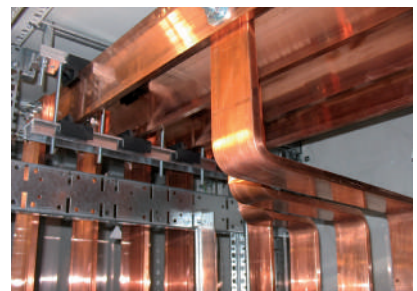
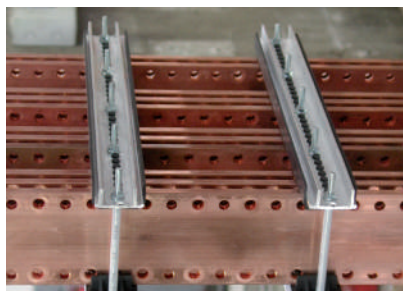

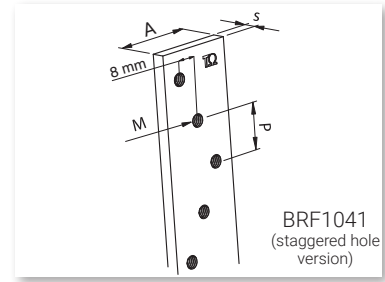
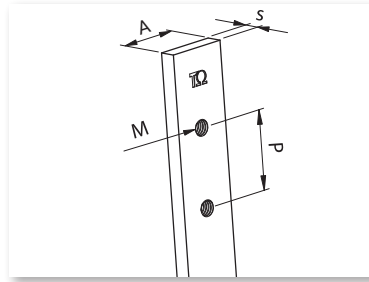

THREADED COPPER BARS

Code	Reference		Weight (kg)	A (mm)	s (mm)	P (mm)	(m)
Length 1000 mm							
BRF0990	BRF 12X2X1000	10	0.22	12	2	18	M5
BRF0995	BRF 12X3X1000	10	0.32	12	3	18	M5
BRF1000	BRF 12X4X1000	10	0.42	12	4	18	M5
BRF1005	BRF 12X5X1000	10	0.49	12	5	18	M5
BRF1010	BRF 15X5X1000	4	0.64	15	5	25	M6
BRF1015	BRF 20X5X1000	4	0.84	20	5	25	M6
BRF1016	BRF 25X4X1000	4	0.80	25	4	25	M6
BRF1017	BRF 25X5X1000	4	1.12	25	5	25	M6
BRF1020	BRF 32X5X1000	4	1.35	32	5	25	M6
BRF1045	BRF 30X10X1000	4	2.49	30	10	25	M8
Length 2000 mm							
BRF1025	BRF 12X4X2000	10	0.84	12	4	18	M5
BRF1030	BRF 15X5X2000	4	1.18	15	5	25	M6
BRF1031	BRF 15X5X2000 PC	4	1.16	15	5	18	M6
BRF1035	BRF 20X5X2000	4	1.66	20	5	25	M6
BRF1036	BRF 20X5X2000 PC	4	1.60	20	5	20	M6
BRF1040	BRF 30X5X2000	4	2.49	30	5	25	M6
BRF1041	BRF 32X5X2000-W	4	2.65	32	5	17.5	M6
BRF1042	BRF 32X5X2000	4	2.85	32	5	25	M6
BRF1047	BRF 30X10X2000	4	4.98	30	10	25	M8

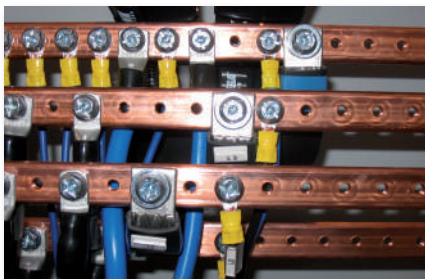

Ampacity table based on the ΔT temperature rise
Reference room temperature $T_a = 35^\circ C$

Code	Dimensions	Sect. (mm ²)	ΔT 35 °C	ΔT 55 °C	ΔT 70 °C	ΔT 105 °C
BRF0990	12 x 2	24	117	150	171	212
BRF0995	12 x 3	36	150	192	218	270
BRF1000 - BRF1025	12 x 4	48	179	229	261	323
BRF1005	12 x 5	60	206	265	301	373
BRF1010 - BRF1030 - BRF1031	15 x 5	75	245	314	357	442
BRF1015 - BRF1035 - BRF1036	20 x 5	100	307	393	448	554
BRF1016	25 x 4	100	322	412	469	581
BRF1017	25 x 5	125	367	470	535	663
BRF1040	30 x 5	150	425	545	621	769
BRF1020 - BRF1041 - BRF1042	32 x 5	160	448	575	655	811
BRF1045 - BRF1047	30 x 10	300	643	825	940	1166

NOTE

For the use of bars in parallel refer to the table on page 40.

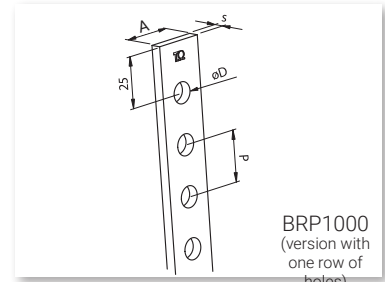
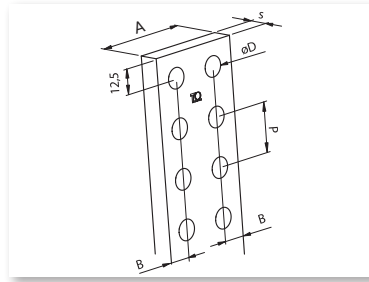
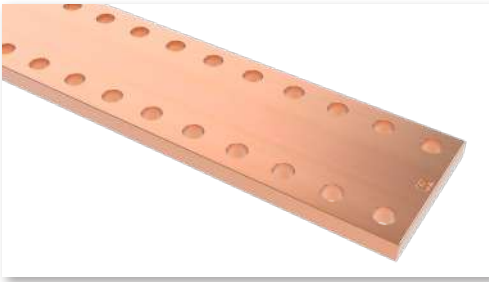

BRP1000
(version with one row of holes)

PREPUNCHED COPPER BARS

Code	Reference		Weight (kg)	A (mm)	s (mm)	P (mm)	øD (mm)	B (mm)
Length 1750 mm								
BRP1000	BRP 25X5	2	1.39	25	5	25	10.5	12.5
BRP1005	BRP 50X5	2	3.39	50	5	25	10.5	12.5
BRP1010	BRP 63X5	2	4.39	63	5	25	10.5	12.5
BRP1015	BRP 80X5	2	5.69	80	5	25	10.5	12.5
BRP1020	BRP 100X5	2	7.24	100	5	25	10.5	12.5
BRP1030	BRP 50X10	2	6.70	50	10	25	10.5	12.5
BRP1035	BRP 60X10	2	8.79	60	10	25	10.5	12.5
BRP1040	BRP 80X10	2	11.30	80	10	25	10.5	12.5
BRP1045	BRP 100X10	2	14.40	100	10	25	10.5	12.5
BRP1050	BRP 120X10	2	18.30	120	10	25	10.5	12.5

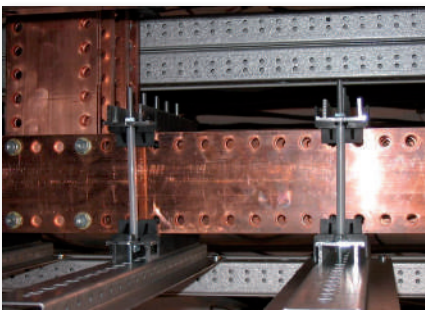

Ampacity Table (A) functional to thermal rise ΔT
Reference room temperature $T_a = 35^\circ\text{C}$

Code	Dimensions	Sect. (mm ²)	ΔT 35 °C	ΔT 55 °C	ΔT 70 °C	ΔT 105 °C
BRP1000	25x5	125	367	470	535	663
BRP1005	50x5	250	649	833	949	1178
BRP1010	63x5	315	788	1012	1153	1433
BRP1015	80x5	400	965	1238	1412	1757
BRP1020	100x5	500	1166	1496	1707	2126
BRP1030	50x10	500	950	1220	1392	1731
BRP1035	60x10	600	1094	1406	1605	1999
BRP1040	80x10	800	1370	1762	2013	2511
BRP1045	100x10	1000	1633	2102	2402	3001
BRP1050	120x10	1200	1887	2429	2777	3474

NOTE

For the use of bars in parallel refer to the table on page 40.

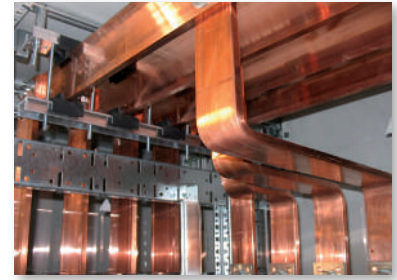
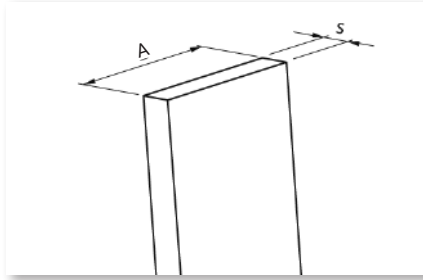

SOLID COPPER BARS

Code	Reference		Code	Reference		Weight (kg/m)	A (mm)	s (mm)
Length 1750 mm			* Length 4200 mm					
PRP2990	PRP 12x4x1750	2	PRP0990	PRP 12X4	1	0.43	12	4
PRP2000	PRP 20x5x1750	2	PRP1000	PRP 20x5	1	0.89	20	5
PRP2005	PRP 25x5x1750	2	PRP1005	PRP 25x5	1	1.11	25	5
PRP2010	PRP 30x5x1750	2	PRP1010	PRP 30x5	1	1.33	30	5
PRP2015	PRP 40x5x1750	2	PRP1015	PRP 40x5	1	1.78	40	5
PRP2020	PRP 50x5x1750	2	PRP1020	PRP 50x5	1	2.23	50	5
PRP2025	PRP 60x5x1750	2	PRP1025	PRP 60x5	1	2.67	60	5
PRP2030	PRP 80x5x1750	2	PRP1030	PRP 80x5	1	3.56	80	5
PRP2035	PRP 100x5x1750	2	PRP1035	PRP 100x5	1	4.45	100	5
PRP2040	PRP 125x5x1750	2	PRP1040	PRP 125x5	1	5.56	125	5
PRP2045	PRP 30x10x1750	2	PRP1045	PRP 30x10	1	2.67	30	10
PRP2050	PRP 40x10x1750	2	PRP1050	PRP 40x10	1	3.56	40	10
PRP2055	PRP 50x10x1750	2	PRP1055	PRP 50x10	1	4.45	50	10
PRP2060	PRP 60x10x1750	2	PRP1060	PRP 60x10	1	5.34	60	10
PRP2065	PRP 80x10x1750	2	PRP1065	PRP 80x10	1	7.12	80	10
PRP2070	PRP 100x10x1750	2	PRP1070	PRP 100x10	1	8.90	100	10
PRP2075	PRP 120x10x1750	2	PRP1075	PRP 120x10	1	10.70	120	10
			PRP1080	PRP 160x10	1	14.25	160	10
			PRP1085	PRP 200x10	1	17.80	200	10

* Length 4200 mm available on request.

Ampacity Table (A) functional to thermal rise ΔT
Reference room temperature $T_a = 35^\circ C$

Code	Dimensions	Sect. (mm ²)	ΔT 35 °C	ΔT 55 °C	ΔT 70 °C	ΔT 105 °C
PRP2990 - PRP0990	12x4	48	179	229	261	323
PRP2000 - PRP1000	20x5	100	307	393	448	554
PRP2005 - PRP1005	25x5	125	367	470	535	663
PRP2010 - PRP1010	30x5	150	425	545	621	769
PRP2015 - PRP1015	40x5	200	539	691	787	976
PRP2020 - PRP1020	50x5	250	649	833	949	1178
PRP2025 - PRP1025	60x5	300	757	971	1106	1375
PRP2030 - PRP1030	80x5	400	965	1238	1412	1757
PRP2035 - PRP1035	100x5	500	1166	1496	1707	2126
PRP2040 - PRP1040	125x5	625	1408	1808	2064	2574
PRP2045 - PRP1045	30x10	300	643	825	940	1166
PRP2050 - PRP1050	40x10	400	800	1027	1171	1455
PRP2055 - PRP1055	50x10	500	950	1220	1392	1731
PRP2060 - PRP1060	60x10	600	1094	1406	1605	1999
PRP2065 - PRP1065	80x10	800	1370	1762	2013	2511
PRP2070 - PRP1070	100x10	1000	1633	2102	2402	3001
PRP2075 - PRP1075	120x10	1200	1887	2429	2777	3474
PRP1080	160x10	1600	2374	3057	3496	4380
PRP1085	200x10	2000	2842	3659	4186	5249

NOTE

For the use of bars in parallel refer to the table on page 40.

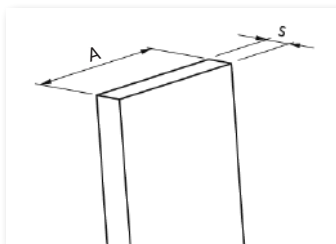

SOLID ALUMINIUM BARS

Code	Reference		Code	Reference		Weight (kg/m)	A (mm)	s (mm)
Length 2000 mm			* Length 4000 mm					
BAP2000	BAP 20x10x2000	2	BAP4000	BAP 20x10x4000	1	0.54	20	10
BAP2005	BAP 30x10x2000	2	BAP4005	BAP 30x10x4000	1	0.81	30	10
BAP2010	BAP 40x10x2000	2	BAP4010	BAP 40x10x4000	1	1.08	40	10
BAP2015	BAP 50x10x2000	2	BAP4015	BAP 50x10x4000	1	1.35	50	10
BAP2020	BAP 60x10x2000	2	BAP4020	BAP 60x10x4000	1	1.62	60	10
BAP2025	BAP 80x10x2000	2	BAP4025	BAP 80x10x4000	1	2.16	80	10
BAP2030	BAP 100x10x2000	2	BAP4030	BAP 100x10x4000	1	2.70	100	10
BAP2035	BAP 120x10x2000	2	BAP4035	BAP 120x10x4000	1	3.24	120	10

* Length 4000 mm available on request.

Ampacity table based on the ΔT temperature rise
Reference room temperature $T_a = 35^\circ\text{C}$

Code	Dimensions	Sect. (mm ²)	ΔT 35 °C	ΔT 55 °C	ΔT 70 °C	ΔT 105 °C
BAP2000 - BAP4000	20 X 10	200	381	487	554	683
BAP2005 - BAP4005	30 X 10	300	517	662	753	929
BAP2010 - BAP4010	40 X 10	400	647	827	941	1164
BAP2015 - BAP4015	50 X 10	500	771	987	1123	1390
BAP2020 - BAP4020	60 X 10	600	891	1141	1299	1609
BAP2025 - BAP4025	80 X 10	800	1123	1438	1638	2033
BAP2030 - BAP4030	100 X 10	1000	1344	1724	1964	2441
BAP2035 - BAP4035	120 X 10	1200	1559	1999	2279	2836

DERATING COEFFICIENT FOR THE USE OF BARS IN PARALLEL

Bar width (A)	Number of bars in parallel		
	//	///	// //
A < 63 mm	1.72	2.25	2.93
63 mm ≤ A < 100 mm	1.65	2.12	2.7
A = 100 mm	1.6	2.02	2.4
A > 100 mm	1.49	1.95	2.4

Table valid for threaded, prepunched and solid bars in both copper and aluminium.

Example of bar choice: for $I_n = 800$ A, for $T_{max} = 90^\circ\text{C}$, with 1 bar per phase.

Cf. tables with $\Delta T = T_{max} - T_a = (90-35) = \Delta 55^\circ\text{C}$ with $I_n \geq 800$ A:

- **copper prepunched bar** 50x5 ($I_n = 833$ A)
- **solid copper bar:** 50x5 ($I_n = 833$ A), 30x10 ($I_n = 825$ A)
- **solid aluminium bar** 50x10 ($I_n = 827$ A)

BOC - Direct hook-up distribution block on copper bars

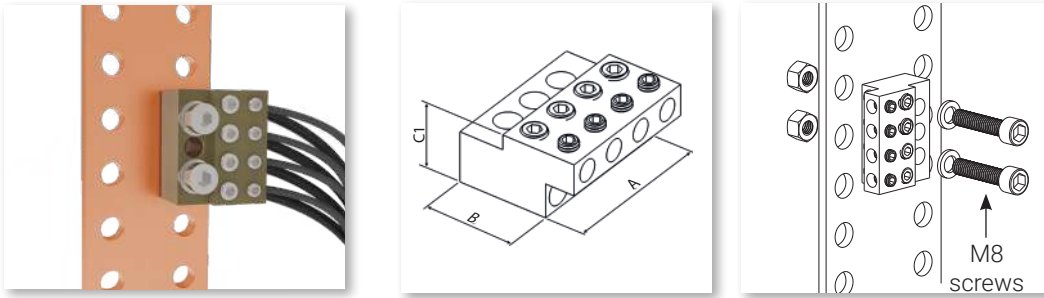

BOC1000 allows direct connection on prepunched bars with 25 mm pitch. The distribution block allows attachment to bars of any thickness.

NOTE

M8 screws are to be tightened with a torque of 6 Nm. Screws not included.

Code	Reference		Weight (kg)	A (mm)	B (mm)	C1 (mm)
BOC1000	BOC RIP 8 *	12	0.22	50	30	22

* 8 output distribution block

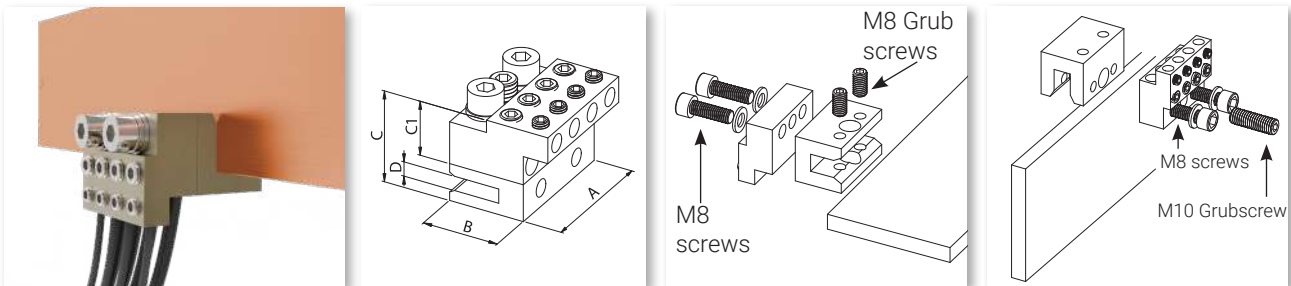

BOC1005 and BOC1010 allow direct connection on prepunched, threaded or solid bars with two different installation configurations.

These distribution blocks can be attached to 5 or 10 mm thick bars.

NOTE

M8 screws are to be tightened with a torque of 6 Nm. M10 screws are to be tightened with a torque of 10 Nm. Hardware included.

Code	Reference		Weight (kg)	A (mm)	B (mm)	C (mm)	C1 (mm)	D (mm)
BOC1005	BOC KIT 8 - 5 **	12	0.39	50	30	37	22	5
BOC1010	BOC KIT 8 - 10 ***	12	0.51	50	30	52	22	10

** 8 output distribution block + connection on 5 mm thick bar 5 mm

*** 8 output distribution block + connection on 10 mm thick bar 10 mm

TECHNICAL FEATURES (valid for BOC1000, BOC1005, BOC1010)

The distribution blocks are made of brass.

Simple and quick derivations with cables up to 25 and/or 35 mm² that can be used up to 400 A.

The connection units allow spacing of drilled bars of the same phase.

Compliant with standard IEC 60947-1

Code	IN/OUT	Sect (mm ²)	Sect. (mm ²)	Nr	Ø (mm)	(Nm)
BOC1000 BOC1005 BOC1010	← OUT	2,5 ÷ 25	2,5 ÷ 16	4	7	3
	← OUT	4 ÷ 35	4 ÷ 25	4	9	6

Cables legend:

Stripped wire

Cable with ferrule

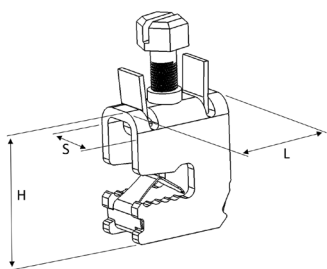



TECHNICAL CHARACTERISTICS

Material: Passivated galvanized steel
Connections on solid bars 5 and 10 mm thick
Suitable for cable cross-sections: from 1.5 to 185 mm²
Compliant with: EN 60998-1
Cable clamps can connect 1 cable each

ADVANTAGES

Easy and quick to use, without punching, even on already mounted bars
Positioning spring
Indirect clamping with plate to prevent damage to files

TERMINALS FOR CABLE

Code	Reference		H (mm)	L (mm)	S (mm)	Cable cross-section (mm ²)	 (Nm)
Terminals for 5 mm thick bars							
MCR1000	MCR 5x16	10	26	22	12	1.5 ÷ 16	3
MCR1005	MCR 5x35	10	31	29	16	16 ÷ 35	6
MCR1010	MCR 5x70	10	39	31	21	35 ÷ 70	10
MCR1015	MCR 5x120	10	44	34	24	70 ÷ 120	15
MCR1017	MCR 5x185	10	50	40	28	120 ÷ 185	30

Terminals for 10 mm thick bars

MCR1020	MCR 10x16	10	31	22	12	1.5 ÷ 16	3
MCR1025	MCR 10x35	10	37	29	16	16 ÷ 35	6
MCR1030	MCR 10x70	10	43	31	21	35 ÷ 70	10
MCR1035	MCR 10x120	10	48	34	24	70 ÷ 120	15
MCR1037	MCR 10x185	10	54	40	28	120 ÷ 185	30

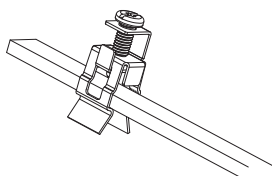



TECHNICAL CHARACTERISTICS

Material: Passivated galvanized steel
Connection on solid bars 12x4 mm
Suitable for cable cross-sections: from 1.5 to 185 mm²
Compliant with: EN 60998-1
Cable clamps can connect 1 cable each

ADVANTAGES

Easy and quick to use, without punching, even on already mounted bars
Mounting clip
Indirect clamping with plate to prevent damage to files

TERMINAL WITH CLIP

Code	Reference		Bar cross-section	No. cable	Cable cross-section (mm ²)	 (Nm)
MCR2000	MCR 4x12	10	12x4	1	1.5 ÷ 16	2

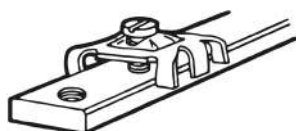
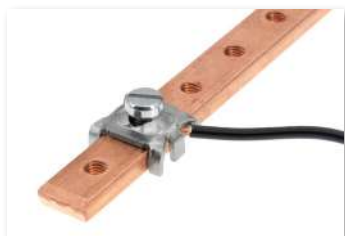

TECHNICAL CHARACTERISTICS

Material: Passivated galvanized steel
Spider connector for threaded bars can be used to connect up to 2 10 mm² cables
Complete with screw M5x12
Compliant with: EN 60998-1

ADVANTAGES

Easy and quick to use, even on already mounted bars
Self-locking
Indirect tightening thus preventing the wire from breaking

SPIDER CONNECTOR FOR THREADED BARS

Code	Reference		Bar cross-section	Cable cross-section (mm ²)	 (Nm)
MCR1100	MCR 4xM5	100	12x4 - 12x5	1.5 ÷ 10	2

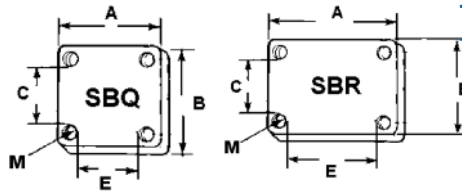

TECHNICAL CHARACTERISTICS

Material: Galvanized steel
 Max. tightening thickness 20 mm
 (with 8.8 screws of length 30 mm
 supplied)
 Compliant with: EN 60998-1
 Plates thickness 5 mm

ADVANTAGES

Connection without drilling and bolting
 Quick and easy use even on already mounted bar systems

BUSBAR CLAMPS FOR SOLID AND FLEXIBLE BARS

Code	Reference		E (mm)	C (mm)	A (mm)	B (mm)	(m) (mm)		(Nm)
SBR1000	SBR 50x24	4	52	26	77	51	M8	10	
SBR1005	SBR 50x32	4	52	34	77	59	M8	10	
SBR1010	SBR 50x40	4	52	42	77	67	M8	10	
SBR1015	SBR 80x24	4	82	26	107	51	M8	10	
SBR1020	SBR 80x32	4	82	34	107	59	M8	10	
SBR1025	SBR 80x50	4	82	52	107	77	M8	10	
SBQ1000	SBQ 30x30	4	32	32	53	53	M8	10	
SBQ1005	SBQ 40x40	4	42	42	63	63	M8	10	
SBQ1010	SBQ 50x50	4	52	52	77	77	M8	10	
SBQ1015	SBQ 63x63	4	65	65	90	90	M8	10	
SBQ1020	SBQ 80x80	4	82	82	115	115	M10	10	
SBQ1025	SBQ 100x100	4	102	102	135	135	M10	10	

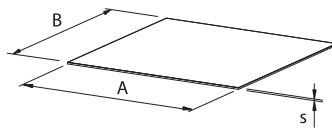

TECHNICAL CHARACTERISTICS

Material: Bimetallic elements consist of copper plated aluminium plates Cu-ETP Cu 99.976
 Copper: 30% of the total weight

ADVANTAGES

Al-Cu connections secure and protected from corrosion

BIMETALLIC (Cu-Al) SHEET

Code	Reference		A (mm)	B (mm)	s (mm)
PBM1000	PBM 100x100	10	100	100	1.0

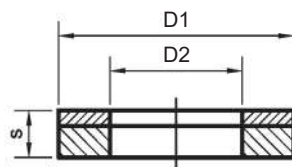

TECHNICAL CHARACTERISTICS

Material: Bimetallic elements consist of copper plated aluminium plates Cu-ETP Cu 99.976
 Copper: 30% of the total weight

ADVANTAGES

Al-Cu connections secure and protected from corrosion

Bimetallic (Cu-Al) Washers

Code	Reference		D1 (mm)	D2 (mm)	s (mm)
PBM2000	RBM M6	100	15	6.5	1.0
PBM2005	RBM M8	100	18	8.5	1.0
PBM2010	RBM M10	50	22	10.5	1.5
PBM2015	RBM M12	50	25	13	2.0

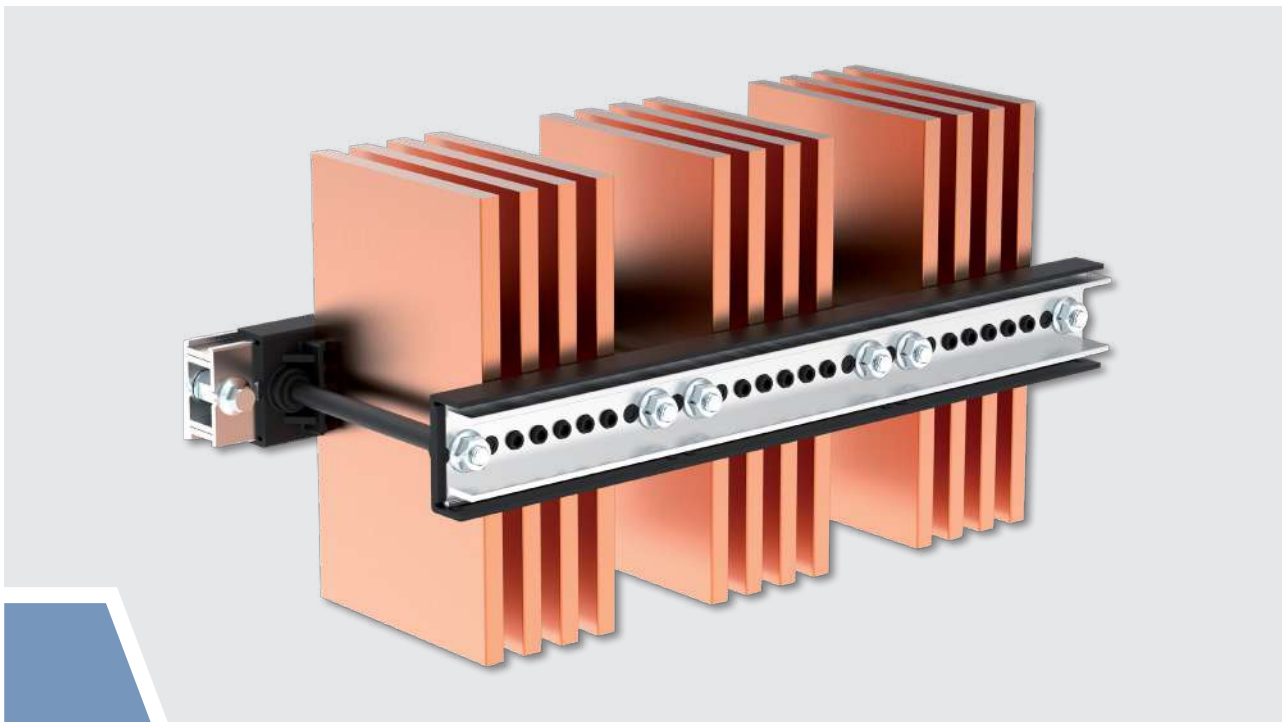

APPLICATIONS

TEKNOMEGA bar supports make it possible to efficiently and conveniently support all copper and/or aluminium bar systems inside an electrical cabinet

The versatility and universality of our bar supports allows the panel board fitter to easily handle the few references to make a wide range of configurations in any type of panel board metalwork.

TEKNOMEGA dedicated particular attention to the efficiency and safety of these products, carrying out TYPE TESTS on all the here indicated references as per the requirements of the reference standards at acknowledged laboratories.

ADVANTAGES

- Complete range to support side and flat bars
- For copper and aluminium bars
- Maximum versatility of use and application
- Quick and simplified universal fitting
- Universal

Can be used on the following thicknesses: 5 - 10 mm
Tested and certified in compliance with standard IEC 61439-2

Maximum continuous operation temperature is:

- TOP and TOP JUNIOR +125 °C 

- TOP FLAT +140 °C 

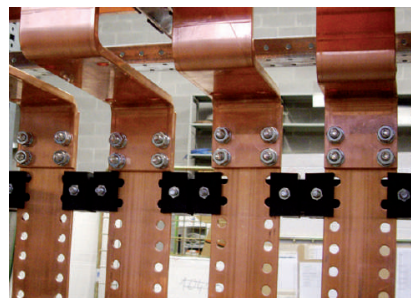
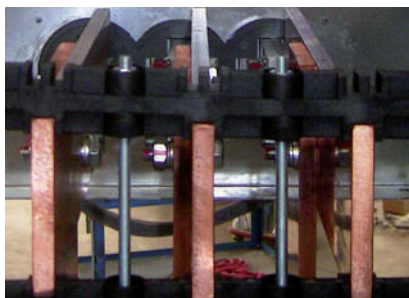
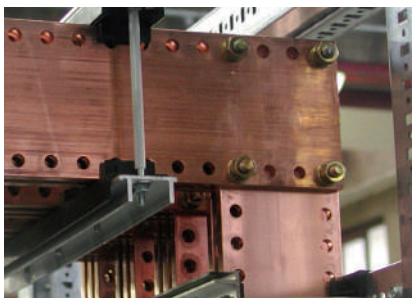

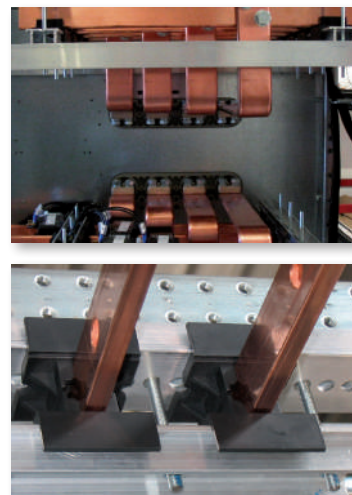

The Ω TOP bar support is built using two references only:

- 1) aluminium support and fitting profile.
- 2) set of blocks/screws with all that is needed to make a bar support.

There are also some pre-assembled bar supports for panel boards 400 and 600 mm depth, as well as accessories such as:

- rilsan tube advised for configurations with minimum spacing between phases
- brackets for horizontal omnibus and vertical busbar (to be used also to compensate the offset between different bar systems).

BLOCKS AND SCREWS SETS Ω TOP 4/10 have a full set of accessories such as PA12 tubes to isolate the threaded rods.

Other versions of **DISTRIBUTION SUPPORT KITS**, which include Alu profile, are available for the 400 and 600 mm depth panel boards.

TECHNICAL CHARACTERISTICS

- Adjustable distance between phases
- Exceptional resistance to short-circuits
- High versatility
- Sets of blocks with screws
- Prepunched support profile in non-magnetic aluminium
- Bar thickness 5 and 10 mm

Certifications:

Compliant with standard IEC 61439-2
CERTIFICATES ACAE-LOVAG

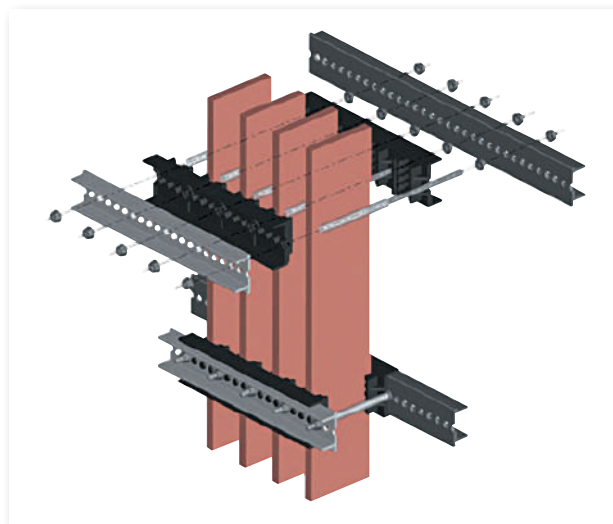

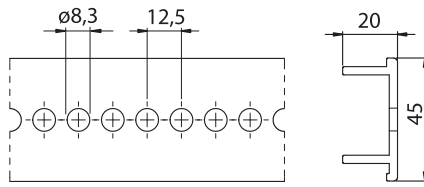

file n° E300607

TECHNICAL CHARACTERISTICS

Material: non-magnetic aluminum alloy
EN AW-6060 T5

SUPPORT PROFILE

Code	Reference		Weight (kg)
TOP1000	TOP PR2000	2	1.2

- One single code for all configurations
- Made of aluminum
- 2 meters long
- Used double, due to the asymmetrical shape, it enables the formation of a structure with high mechanical strength (for large horizontal loads)

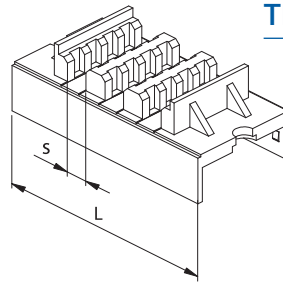
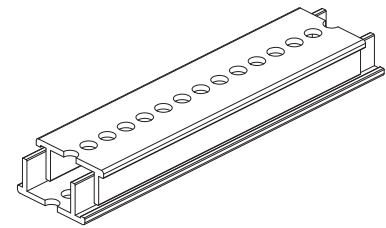

file n° E300607

TECHNICAL CHARACTERISTICS

Material: PA 6.6 reinforced
Color: black
35% fiberglass
Self-extinguishing: UL 94-V0

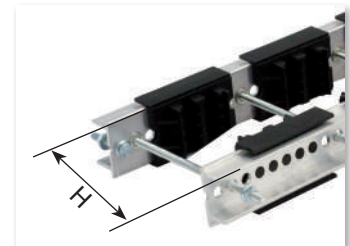

BLOCKS AND SCREW SET

Code	Reference		Type	Total No. blocks	No. Tie-rods	No. bars	s (mm)	H* min-max (mm)	L (mm)
TOP1005	TOP 2/5T	1	T	6	4	1÷2	5	30-130	50
TOP1010	TOP 2/5TN	1	T+N	8	5	1÷2	5	30-130	50
TOP1015	TOP 4/5T	1	T	6	4	1÷4	5	30-130	75
TOP1020	TOP 4/5TN	1	T+N	8	5	1÷4	5	30-130	75
TOP1025	TOP 1/10T	1	T	6	4	1	10	30-130	50
TOP1030	TOP 1/10TN	1	T+N	8	5	1	10	30-130	50
TOP1035	TOP 2/10T	1	T	6	4	1÷2	10	30-130	75
TOP1040	TOP 2/10TN	1	T+N	8	5	1÷2	10	30-130	75
TOP1045	TOP 3/10T	1	T	6	4	1÷3	10	30-130	100
TOP1050	TOP 3/10TN	1	T+N	8	5	1÷3	10	30-130	100

* H = bar width

The set is made of insulating blocks for 5 to 10 mm thick bars and of all the screws and tie-rods needed to make T (3-pole) or T+N (3-pole+neutral) configured bar support

Example: To make a bar support in config.
Three-phase + Neutral (TN), with 2 bars per phase
10 mm thick (2/10) = 2/10 TN

Select: Aluminium profile TOP1000
Set of blocks and screws TOP1040

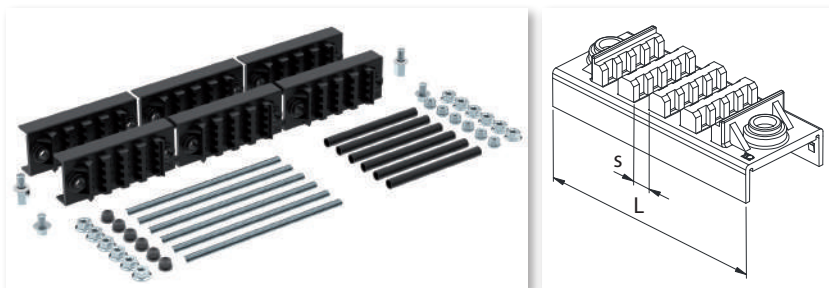

TECHNICAL CHARACTERISTICS

Material: PA 6.6 reinforced 35% fiberglass

Color: black

Self-extinguishing: UL 94-V0

The TOP1052 and TOP1053 kits also include PA12 tubes for M8 tie-rod insulation.

BLOCKS AND SCREW SET Ω TOP 4/10

Code	Reference		Type	No. blocks	No. Tie-rods	No. bars	s (mm)	H* min-max (mm)	L (mm)
TOP1052	TOP 4/10T	1	T	6	6	1÷4	10	30-120	125
TOP1053	TOP 4/10TN	1	T+N	8	8	1÷4	10	30-120	125

* H = bar width

TECHNICAL CHARACTERISTICS

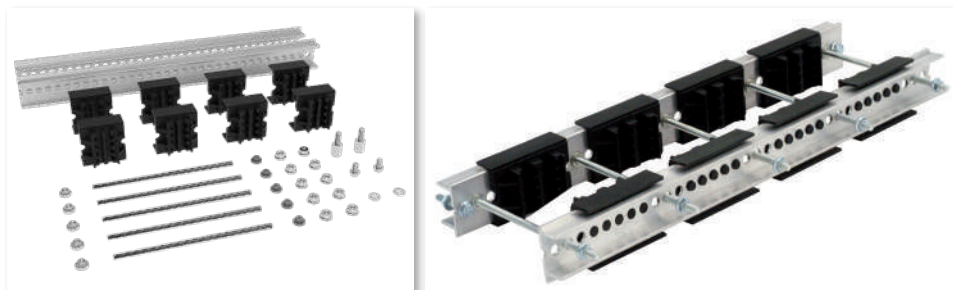

Profile: see TOP1000

Blocks

Material: PA 6.6 reinforced 35% fiberglass

Color: black

Self-extinguishing: UL 94-V0

 file n° E300607

BAR SUPPORT KIT

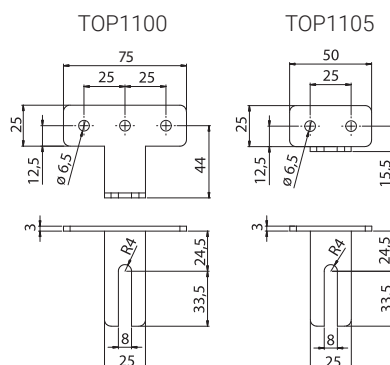

Code	Reference		Type	For panel depth (mm)
TOP1060	TOP 2/5TN-400	1	T+N	400
TOP1065	TOP 1/10TN-400	1	T+N	400
TOP1070	TOP 2/5TN-600	1	T+N	600
TOP1075	TOP 2/10TN-600	1	T+N	600

TECHNICAL CHARACTERISTICS



Material TOP1055: PA12

Working temperature:

 -40 °C ÷ +80 °C 

Material TOP1100 - TOP1105: Galvanized steel

 file n° E300607

ACCESSORIES

Code	Reference	Description	
TOP1055	TOP TI	Pipe for insulation tie rod Ø8x6, L = 140mm	100
TOP1100	TOP SQ-O	Bracket for horizontal busbar - 3 holes	10
TOP1105	TOP SQ-V	Bracket for vertical busbar - 2 holes	10

USEFUL AND IMPORTANT INFORMATION

- The distances between supports (in mm) are calculated taking into account the yield strength of copper; therefore, the values given, do not allow permanent deformation of the copper bars, stressed by the short circuit.
 - The first and last bar support must be assembled at a distance from the bar extremities not exceeding 1/4 of the distance requested between supports.
 - For short-circuit resistance values other than or intermediate to the indicated ones:
 - For configurations other than the indicated ones:
 - For distances between phases intermediate or higher than the indicated ones:
 - For aluminium bars
- PLEASE USE OUR SOFTWARE 
- The first indicated value as the "Spacing between phases" is the minimum possible obtainable for the specific configuration of bar supports (values marked in bold in the tables).
 - For some minimum phase spacing configurations, it may be difficult for internal phases to inserting the hardware; it is recommended to mount one phase at a time.
 - In configurations with minimum spacing between phases, one should use the TOP1055 RILSAN tube to insulate the tie-rod.

Important

- For configurations starting with No. 2 80x10 copper bars or No. 3 50x10 copper bars per phase, it is recommended to use the DOUBLE aluminum profile (i.e., two profiles coupled, one inside the other, to create a kind of square tube of considerable mechanical rigidity).

Distance between supports depending on Icc (short-circuit current)

$I_{cc\ pk}$ = Short-circuit current peak value expressed in kA
 $I_{cc\ rms}$ = Effective value of short-circuit current, duration equal to 1 second, expressed in kA

Ω TOP 4 / 10 >> 4 BARS PER PHASE

Icc pk (kA)		105			165			187			220			264		
Icc rms (kA)		50			75			85			100			120		
Spacing between the phases (mm)		125	150	175	125	150	175	125	150	175	125	150	175	125	150	175
BAR CROSS-SECTION H x s	50X10	900	900	900	600	657	710	498	580	626	359	431	503	249	299	349
	60X10	900	900	900	639	720	778	498	597	686	359	431	503	249	299	349
	80X10	900	900	900	639	767	895	498	597	697	359	431	503	249	299	349
	100X10	900	900	900	639	767	895	498	597	697	359	431	503	249	299	349
	120X10	900	900	900	639	767	895	498	597	697	359	431	503	249	299	349

Ω TOP 4 / 10 >> 3 BARS PER PHASE

Icc pk (kA)		105			165			187			220			242		
Icc rms (kA)		50			75			85			100			110		
Spacing between the phases (mm)		125	150	175	125	150	175	125	150	175	125	150	175	125	150	175
BAR CROSS-SECTION H x s	50X10	817	895	900	520	569	615	458	502	542	332	399	461	274	329	384
	60X10	895	900	900	569	624	674	460	550	594	332	399	465	274	329	384
	80X10	900	900	900	591	709	778	460	552	644	332	399	465	274	329	384
	100X10	900	900	900	591	709	828	460	552	644	332	399	465	274	329	384
	120X10	900	900	900	591	709	828	460	552	644	332	399	465	274	329	384

• values marked in bold refer to the MINIMUM spacing between phases

Ω TOP 3 / 10 >> 3 BARS PER PHASE

Icc pk (kA)	105				143				165				187				220				
Icc rms (kA)	50				65				75				85				100				
Spacing between the phases (mm)	100	125	150	175	100	125	150	175	100	125	150	175	100	125	150	175	100	125	150	175	
BAR CROSS-SECTION H x s	30x10	566	633	693	749	415	464	509	549	360	402	441	476	317	355	389	420	249	302	330	357
	40x10	653	730	800	864	480	536	587	635	416	465	509	550	345	410	449	485	249	312	374	412
	50x10	730	817	895	900	536	600	657	710	444	520	569	615	345	432	502	542	249	312	374	437
	60x10	800	895	900	900	587	657	720	777	444	555	624	674	345	432	518	594	249	312	374	437
	80x10	900	900	900	900	591	739	831	898	444	555	666	777	345	432	518	605	249	312	374	437
	100x10	900	900	900	900	591	739	887	900	444	555	666	777	345	432	518	605	249	312	374	437
	120x10	900	900	900	900	591	739	887	900	444	555	666	777	345	432	518	605	249	312	374	437

Ω TOP 2 / 10 >> 2 BARS PER PHASE

Icc pk (kA)	74				105				165				187				
Icc rms (kA)	35				50				75				85				
Spacing between the phases (mm)	75	100	125	150	75	100	125	150	75	100	125	150	75	100	125	150	
BAR CROSS-SECTION H x s	30x10	571	660	738	808	400	462	516	566	254	294	328	360	224	259	290	317
	40x10	660	762	852	900	462	533	596	653	294	339	379	416	254	299	335	367
	50x10	738	852	900	900	516	596	667	730	326	379	424	465	254	335	374	410
	60x10	808	900	900	900	566	653	730	800	326	416	465	509	254	338	410	449
	80x10	900	900	900	900	653	754	844	900	326	435	537	588	254	338	423	508
	100x10	900	900	900	900	730	844	900	900	326	435	544	652	254	338	423	508
	120x10	900	900	900	900	900	900	900	900	326	435	544	652	254	338	423	508

Ω TOP 1 / 10 >> 1 BAR PER PHASE

Icc pk (Ka)	52				74				105				143				
Icc rms (Ka)	25				35				50				65				
Spacing between the phases (mm)	50	75	100	125	50	75	100	125	50	75	100	125	50	75	100	125	
BAR CROSS-SECTION H x s	30x10	462	566	653	730	330	404	466	522	231	283	326	365	169	207	240	268
	40x10	533	653	754	844	381	466	539	602	266	326	377	422	195	240	277	309
	50x10	596	730	844	900	426	522	602	674	298	365	422	471	219	268	309	346
	60x10	653	800	900	900	466	571	660	738	326	400	462	516	240	293	339	379
	80x10	754	900	900	900	539	660	762	852	377	462	533	596	258	339	391	438
	100x10	844	900	900	900	602	738	852	900	422	516	596	667	258	379	438	489
	120x10	900	900	900	900	660	808	900	900	462	566	653	730	258	387	480	536

• values marked in bold refer to the MINIMUM spacing between phases

Distance between supports depending on Icc (short-circuit current)

Icc pk = Short-circuit current peak value expressed in kA

Icc rms = Effective value of short-circuit current, duration equal to 1 second, expressed in kA

Ω TOP 4 / 5 >> 4 BARS PER PHASE

Icc pk (kA)	53				74				105				143				165				
Icc rms (kA)	25				35				50				65				75				
Spacing between the phases (mm)	75	100	125	150	75	100	125	150	75	100	125	150	75	100	125	150	75	100	125	150	
BAR CROSS-SECTION H x s	30x5	550	640	720	780	400	460	510	560	270	310	340	380	210	240	270	290	180	210	230	250
	40x5	640	740	830	900	460	530	590	650	310	360	400	440	240	270	310	340	200	240	270	290
	50x5	715	830	900	900	510	590	660	720	340	400	440	490	265	310	340	370	200	265	300	320
	63x5	800	900	900	900	570	660	740	810	390	450	500	550	265	340	380	420	200	265	330	360
	80x5	900	900	900	900	650	750	840	900	440	500	560	620	265	355	430	470	200	265	330	400
	100x5	900	900	900	900	720	840	900	900	450	560	630	690	265	355	430	530	200	265	330	400
	125x5	900	900	900	900	810	900	900	900	450	600	700	770	265	355	430	530	200	265	330	400

Ω TOP 4 / 5 >> 3 BARS PER PHASE

Icc pk (kA)	53				74				105				143				165				
Icc rms (kA)	25				35				50				65				75				
Spacing between the phases (mm)	75	100	125	150	75	100	125	150	75	100	125	150	75	100	125	150	75	100	125	150	
BAR CROSS-SECTION H x s	30x5	480	550	620	680	340	400	440	490	230	270	300	330	180	210	230	250	150	180	200	220
	40x5	550	640	720	780	400	460	510	560	270	310	340	380	210	240	270	290	175	210	230	250
	50x5	620	720	800	880	440	510	570	630	300	340	390	420	230	270	300	320	175	230	260	280
	63x5	700	800	900	900	500	570	640	700	330	390	430	470	230	300	330	360	175	230	290	320
	80x5	780	900	900	900	560	650	720	790	380	440	490	530	230	310	370	410	175	230	290	345
	100x5	880	900	900	900	630	720	810	890	390	490	540	600	230	310	385	460	175	230	290	345
	125x5	900	900	900	900	700	810	900	900	390	520	610	670	230	310	385	465	175	230	290	345

• values marked in bold refer to the MINIMUM spacing between phases
* value less than 100 mm

Distance between supports depending on Icc (short-circuit current)

Icc pk = Short-circuit current peak value expressed in kA

Icc rms = Effective value of short-circuit current, duration equal to 1 second, expressed in kA

Ω TOP 2 / 5 >> 2 BARS PER PHASE

Icc pk (kA)	53				74				105				143				
Icc rms (kA)	25				35				50				65				
Spacing between the phases (mm)	50	75	100	125	50	75	100	125	50	75	100	125	50	75	100	125	
BAR CROSS-SECTION H x S	30x5	320	390	450	510	230	280	320	360	150	190	220	240	120	150	170	190
	40x5	370	450	520	580	260	320	370	420	180	220	250	280	140	170	190	220
	50x5	410	510	580	650	300	360	420	470	200	240	280	310	150	190	220	240
	63x5	460	570	660	730	330	410	470	520	220	270	320	350	170	210	240	270
	80x5	520	640	740	830	370	460	530	590	250	310	360	400	165	240	270	310
	100x5	580	720	830	900	420	510	590	660	280	340	400	440	165	250	310	340
	125x5	650	800	900	900	470	570	660	740	285	390	440	500	165	250	335	380

Ω TOP 2 / 5 >> 1 BARS PER PHASE

Icc pk (kA)	53				74				105				143				
Icc rms (kA)	25				35				50				65				
Spacing between the phases (mm)	50	75	100	125	50	75	100	125	50	75	100	125	50	75	100	125	
BAR CROSS-SECTION H x S	30x5	225	280	320	360	160	200	230	260	110	135	155	175	-*	100	120	130
	40x5	265	320	370	415	190	230	265	300	125	155	180	200	-*	120	135	155
	50x5	295	360	415	465	210	260	300	335	140	175	200	225	110	130	155	170
	63x5	330	405	470	525	235	290	335	375	160	195	225	250	120	150	170	195
	80x5	370	455	530	585	265	325	375	420	180	220	255	285	135	170	195	220
	100x5	415	510	585	655	300	365	420	470	200	245	285	315	155	190	220	245
	125x5	465	570	655	735	335	405	470	525	225	275	315	355	155	210	245	275

• values marked in bold refer to the MINIMUM spacing between phases
* value less than 100 mm



TECHNICAL CHARACTERISTICS

- High versatility
- Space between phases 70 mm
- High resistance to short-circuit
- Unique solution for supporting 5 and 10 mm thick bars
- Fitting directly on 400 mm deep panel boards
- Adjustable fasteners supplied

- Max. working temperature : +125 °C 

Material:

Polyamide 6.6 reinforced with 35% fiberglass
Self-extinguishing UL 94-V0
Color: black

Certifications:

Compliant with standard IEC 61439-2
CERTIFICATE ACAE-LOVAG

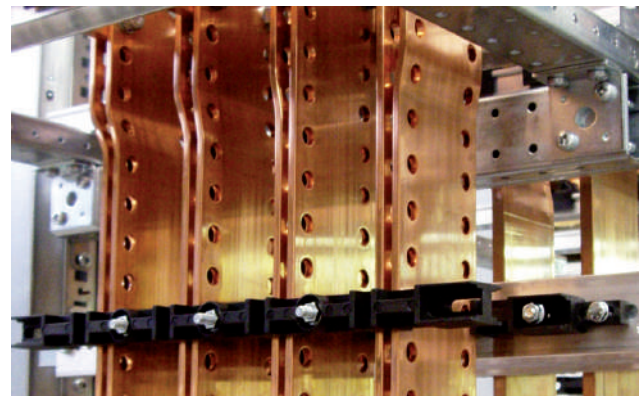
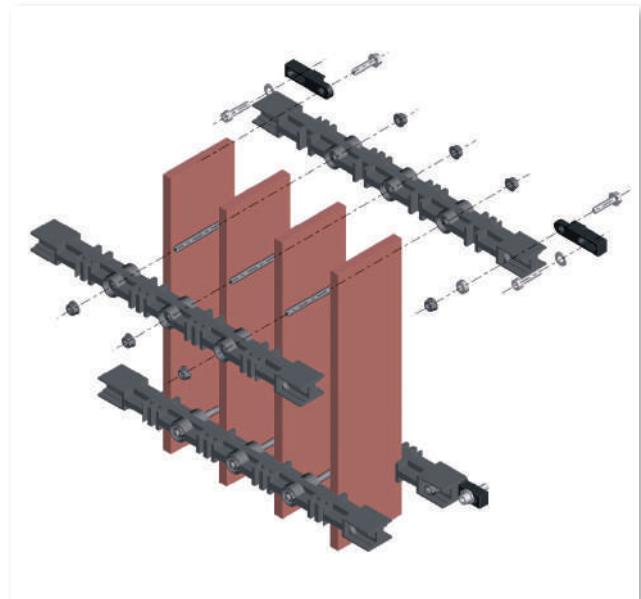

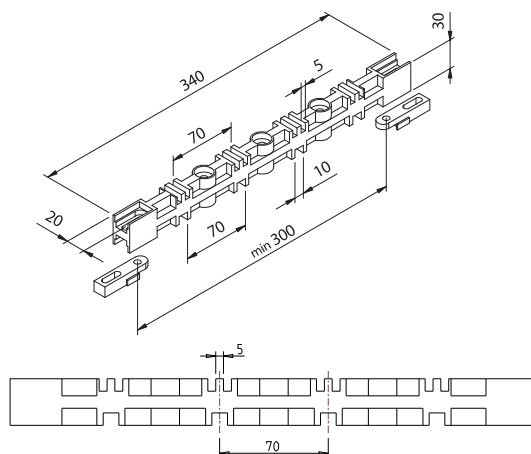

Code	Reference		Type	No. Tie-rods	No. bars	s (mm)	H* min ÷ max (mm)
TOP2000	TOP J 5-10	2	T + N	3	1-2	5	30 ÷ 80
					1	10	30 ÷ 80

* H = bar width

Distance between supports depending on Icc (short-circuit current)

Icc pk = Short-circuit current peak value expressed in kA

Icc rms = Effective value of short-circuit current, duration equal to 1 second, expressed in kA

Ω TOP JUNIOR 1 / 10 >> 1 BARS PER PHASE

Icc pk (kA)		53	74	110	132
Icc rms (kA)		25	35	50	60
Spacing between phases (mm)		70			
BAR CROSS-SECTION H x s	30x10	540	385	260	200
	40x10	620	445	285	200
	50x10	695	495	285	200
	60x10	760	545	285	200
	80x10	870	630	285	200

Ω TOP JUNIOR 2 / 5 >> 1 BAR PER PHASE

Icc pk (kA)		53	74	110	132
Icc rms (kA)		25	35	50	60
Spacing between phases (mm)		70			
BAR CROSS-SECTION H x s	30x5	270	190	130	105
	40x5	310	220	150	125
	50x5	350	250	165	129
	60x5	380	275	180	129
	80x5	390	310	210	129

Ω TOP JUNIOR 2 / 5 >> 2 BAR PER PHASE

Icc pk (kA)		53	74	110	132
Icc rms (kA)		25	35	50	60
Spacing between phases (mm)		70			
BAR CROSS-SECTION H x s	30x5	380	270	180	150
	40x5	440	310	210	165
	50x5	490	350	235	165
	60x5	540	385	240	165
	80x5	620	445	240	165

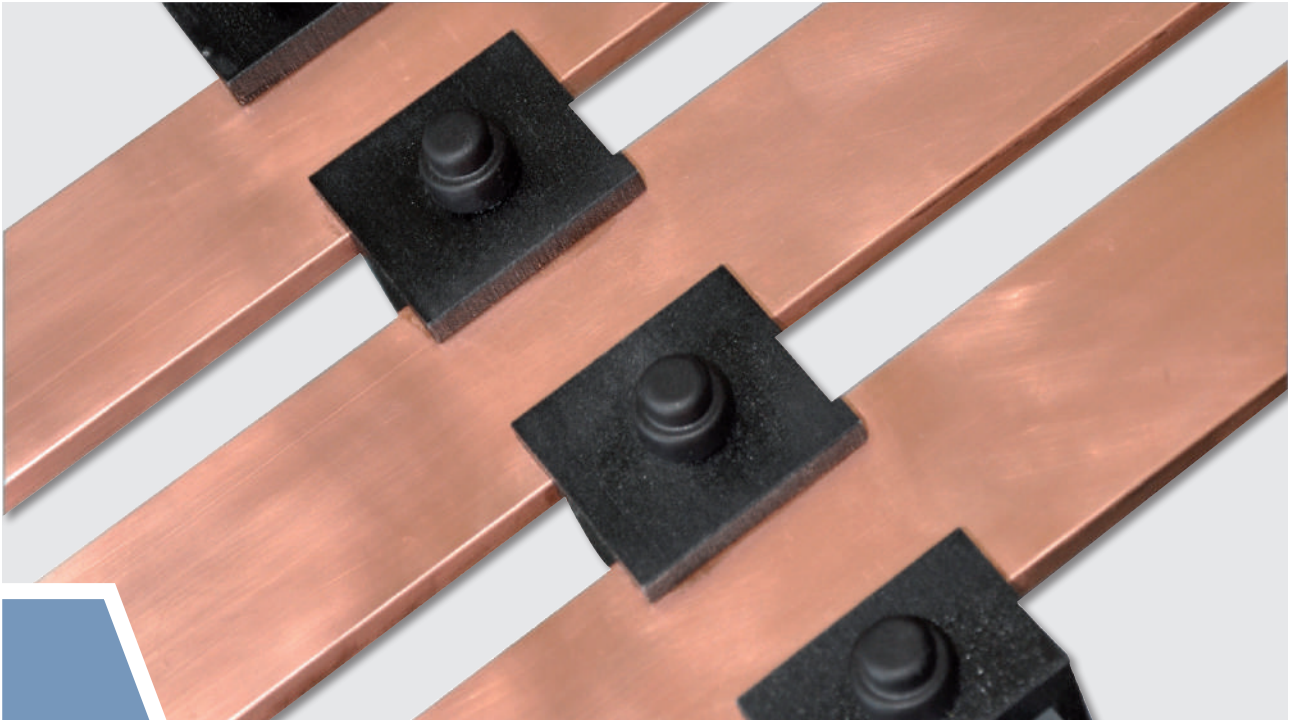

The Ω FLAT bar support is a **UNIVERSAL, QUICK and CONVENIENT** solution for supporting bars, copper or aluminium, in a flat configuration.

It is mainly made of two elements:

- 1) supporting and fastening profile
- 2) set of blocks and screws to tighten the bars

The Ω FLAT bar support can also be used as a support system for flexible insulated bars COFLEX and J-LINK.

TECHNICAL CHARACTERISTICS

Universal

- Distance between stages predefined according to the width of the bars or adjustable at installation
- Rigid bar thickness 4 to 10 mm
- Flexible bar (COFLEX) up to 6 laminates of 1 mm
- Flexible shunts (J-LINK) up to 85mm²
- High resistance to short-circuit
- Air distance between two phases:
 - 20 mm with "T" blocks
 - 40 mm with "L" blocks", incrementable by spacing the blocks
- Max. working temperature : +140 °C 

Insulating blocks:

In 6.6 polyamide reinforced with 30% fiberglass
 Color: black
 Self-extinguishing: UL 94-V0
 Halogen free

Support Profile:

Made in extruded PVC
 Self-extinguishing: UL 94-V0
 Color: black

Certifications:

Compliant with standard IEC 61439-2
 CERTIFICATE ACAE-LOVAG

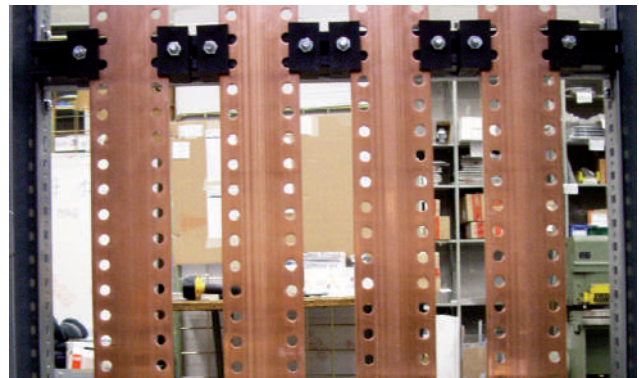
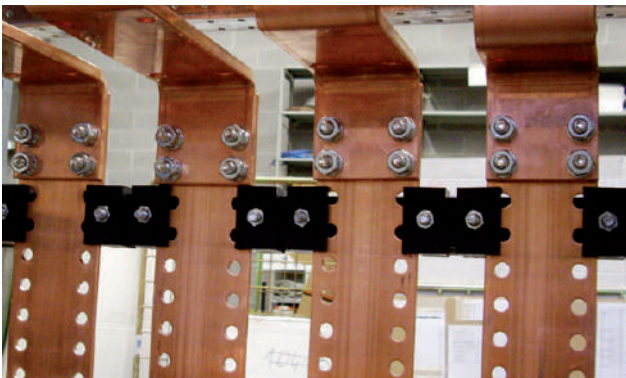
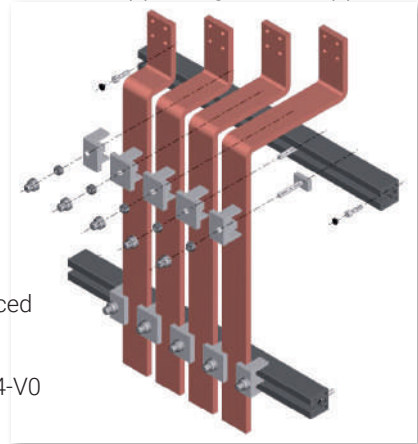

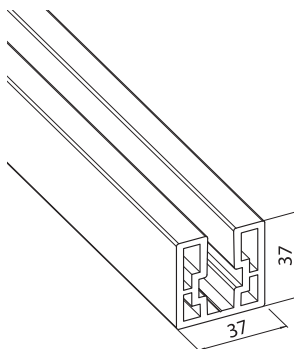

TECHNICAL CHARACTERISTICS

Material: extruded PVC
Color: black
Self-extinguishing: UL 94-V0
Length: 2 m

One single code for all configurations. Quick fitting to the panel board structure by means of hex socket head cap screws M6x25, to be used after punching the bottom guiding profile.

Maximum working temperature: +80 °C

SUPPORT PROFILE

Code	Reference		Weight (kg)
FLT1000	FLT PR 2000	2	1.90

TECHNICAL CHARACTERISTICS

Material: Polyamide 6.6 reinforced with 30% fiberglass
Color: black
Self-extinguishing: UL 94-V0
 Halogen free

Maximum working temperature: +140 °C

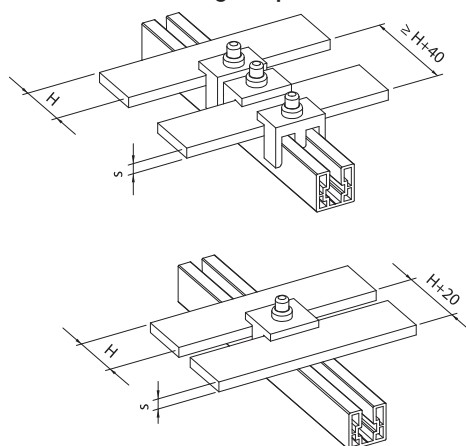
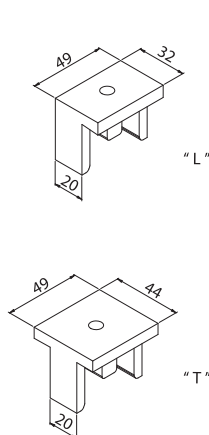

INSULATING BLOCKS AND SCREWS

Code	Reference		Phases	No. blocks "L"	No. blocks "T"	s min-max (mm)	H* min-max (mm)	Spacing between the phases (mm)
FLT1015	FLT LT-T	1	T	2	2	4-10	30-100	H + 20
FLT1020	FLT LT-TN	1	T+N	2	3			H + 20
FLT1025	FLT LL-T	1	T	6	-			≥ H + 40
FLT1030	FLT LL-TN	1	T+N	8	-			≥ H + 40

* H = bar width

The set consists of insulating blocks, hammer head screws M8x45, hexagonal nuts M8 and insulating nut caps. complete with hex socket head cap screws M6x25 to fasten profile FLT1000 and plastic caps to insulate the head screws M6x25.

Example:

to make a bar support configuration
 3-pole + Neutral (Phases=T+N) at **MINIMUM** distance between phases (=H+20 mm)

Select: PVC profile Length. 2 meters **FLT1000**
 Insulating Blocks and Screws **FLT1020**

Distance between supports depending on I_{cc} (short-circuit current)

I_{cc pk} = Short-circuit current peak value expressed in kA

I_{cc rms} = Effective value of short-circuit current, duration equal to 1 second, expressed in kA

CONFIGURATIONS USING FLT1015 - FLT1020

I _{cc pk} (kA)		53						74						84					
I _{cc rms} (kA)		25						35						40					
Spacing between the phases (mm)		50	60	70	80	100	120	50	60	70	80	100	120	50	60	70	80	100	120
BAR WIDTH H (mm)	30	240	-	-	-	-	-	120	-	-	-	-	-	95	-	-	-	-	-
	40	-	290	-	-	-	-	-	150	-	-	-	-	-	115	-	-	-	-
	50	-	-	335	-	-	-	-	-	170	-	-	-	-	-	135	-	-	-
	60	-	-	-	385	-	-	-	-	-	195	-	-	-	-	-	150	-	-
	80	-	-	-	-	480	-	-	-	-	-	245	-	-	-	-	-	190	-
	100	-	-	-	-	-	575	-	-	-	-	-	295	-	-	-	-	-	230

CONFIGURATIONS USING FLT1025 - FLT1030

I _{cc pk} (kA)		53								74								84							
I _{cc rms} (kA)		25								35								40							
Spacing between the phases (mm)		70	80	90	100	120	140	160	70	80	90	100	120	140	160	70	80	90	100	120	140	160			
BAR WIDTH H (mm)	30	335	385	430	480	575	675	770	170	195	220	245	295	345	390	135	150	170	190	230	265	305			
	40	-	385	430	480	575	675	770	-	195	220	245	295	345	390	-	150	170	190	230	265	305			
	50	-	-	430	480	575	675	770	-	-	220	245	295	345	390	-	-	170	190	230	265	305			
	60	-	-	-	480	575	675	770	-	-	-	245	295	345	390	-	-	-	190	230	265	305			
	80	-	-	-	-	575	675	770	-	-	-	-	295	345	390	-	-	-	-	230	265	305			
	100	-	-	-	-	-	675	770	-	-	-	-	-	345	390	-	-	-	-	-	265	305			

NOTE:

- = not possible configuration

Values marked in bold refer to the MINIMUM spacing between phases

For configurations other than the indicated ones: please contact our technical office



"Standoff" and "column" insulators, used as insulating supports for active lessees, provide excellent electrical insulation capacity. They can be used as support of electrical equipment offering high mechanical strength values, as well as a spacer and/or stiffening element in a system consisting of lessee bars (copper or aluminum). Different heights, different widths, and different sizes of threaded inserts allow you to select the most appropriate product for the specific installation.

The **TEKNOMEGA** range offers two product types, both with high electrical insulation and mechanical resistance characteristics, obtained using different production processes and materials.

- Ω COMPHEX: RED INSULATORS and SPACING COLUMNS

made of polyester reinforced with fiberglass, molded by compression.

- Ω ISO: BLACK INSULATORS and SPACING COLUMNS

made of polyamide reinforced with fiberglass, molded by injection.

BOTH ranges of **TEKNOMEGA** INSULATOR have passed severe TESTS to check their mechanical and electrical resistance.

The values obtained during the tests are indicated in the relevant technical tables.

The tests were carried out in compliance with standards EN 60664-1 and EN 61439-1.

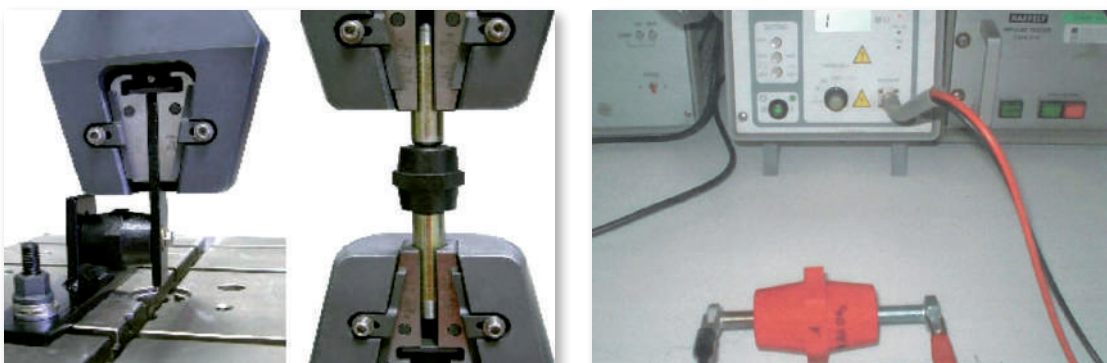

Ω COMP RHEX - Insulators in polyester

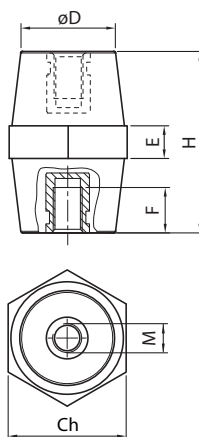

TECHNICAL CHARACTERISTICS

Insulation:

Material: Thermosetting Polyester
Reinforced with 20% fiberglass

Color: Red RAL 3031

Self-extinguishing: UL 94-V0

Threaded inserts:

Galvanized steel

Finished product:

Rated voltage: 1000 V AC / 1500 V DC

Working temperature: -40 °C ÷ +130 °C

R.T. = Tensile strength

R.C. = Compressive strength

R.F. = Flexural strength

Code	Reference		Weight (kg)	H (mm)	Ch (mm)	Type	øD (mm)	E (mm)	M	F (mm)		R.T. (kN)	R.C. (kN)	R.F. (kN)
CPH2000	CPH 16M4	50	0,007	16	15	●	12	4	M4	5	3	1,5	15	1
CPH2005	CPH 20M4	25	0,014	20	19	●	16	5	M4	6	3	2	20	1,5
CPH2007	CPH 20M5	25	0,014						M5	6	6	2	20	1,5
CPH2010	CPH 20M6	25	0,012						M6	6	8	2,4	20	2,4
CPH2015	CPH 25M5	20	0,019	25	22	●	18	6	M5	7	6	2,4	29	2,2
CPH2020	CPH 25M6	20	0,022						M6	7	10	3,4	29	2,2
CPH2025	CPH 30M6	10	0,064	30	30	●	25	7	M6	10	10	5,8	59	4,6
CPH2030	CPH 30M8	10	0,062						M8	10	25	5,8	59	3,9
CPH2035	CPH 35M6	10	0,083	35	32	●	28	10	M6	12	10	7,1	90	4
CPH2040	CPH 35M8	10	0,081						M8	12	25	7,1	90	5,1
CPH2045	CPH 35M10	10	0,077		M10	12	50	7,1	90	4,8				
CPH2046	CPH 35M8W	10	0,109		41	●	35	10	M8	12	25	7,9	130	6,7
CPH2048	CPH 35M10W	10	0,108	M10					12	50	7,9	130	6,7	
CPH2050	CPH 40M6	10	0,126	40	41	●	34	12	M6	12	10	9	120	5
CPH2055	CPH 40M8	10	0,127						M8	15	25	9	120	5
CPH2060	CPH 40M10	10	0,122						M10	15	50	8	120	5
CPH2065	CPH 45M6	10	0,173	45	46	●	39	13	M6	12	10	9	140	5,4
CPH2070	CPH 45M8	10	0,166						M8	15	25	9	140	6,5
CPH2075	CPH 45M10	10	0,165						M10	15	50	11	140	6,5
CPH2080	CPH 50M6	10	0,178	50	46	●	37	10	M6	12	10	11	120	4,8
CPH2085	CPH 50M8	10	0,172						M8	15	25	11	120	5,5
CPH2090	CPH 50 M10	10	0,168		M10	15	50	11	120	5,5				
CPH2093	CPH 50M12W	10	0,240	50	50	●	45	15	M12	20	85	12,5	160	7,2
CPH2095	CPH 60M8	4	0,330	60	60	●	49	15	M8	15	25	14	180	7,5
CPH2100	CPH 60M10	4	0,330						M10	20	50	14	180	7,5
CPH2102	CPH 65M10	10	0,170	65	41	●	32	12	M10	20	50	15	120	10
CPH2101	CPH 70M10	4	0,409	70	60	●	52	14	M10	20	50	15	170	8
CPH2103	CPH 70M12	4	0,400						M12	20	85	18	170	8
CPH2104	CPH 75M10	10	0,267	75	50	●	38	16	M10	20	50	18	120	13
CPH2105	CPH 75M12	10	0,299						M12	20	85	14	120	6,5
CPH2112	CPH 80M12	3	0,485	80	65	●	52	16	M12	20	85	18	> 200	10
CPH2115	CPH 100M12	2	0,535	100	65	●	52	18	M12	25	85	20	> 200	9
CPH2117	CPH 100M16	2	0,520						M16	25	200	20	> 200	9

Threaded studs for insulators cf. page 62

Type: ● = 6 sides

*Recommended torque values for screws of strength class 8.8

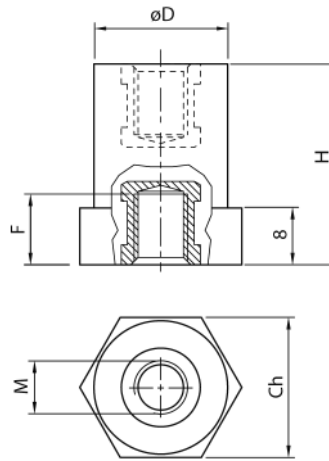

TECHNICAL CHARACTERISTICS

Insulation:
Material: Thermosetting Polyester
 Reinforced with 20% fiberglass
Color: Red RAL 3031
Self-extinguishing: UL 94-V0

Threaded inserts:
 Galvanized steel

Finished product:
 Rated voltage: 1000 V AC / 1500 V DC
 Working temperature: $-40^{\circ}\text{C} \div +130^{\circ}\text{C}$

R.T. = Tensile strength

R.C. = Compressive strength

R.F. = Flexural strength

Code	Reference		Weight (kg)	H (mm)	Ch (mm)	Type	øD (mm)	M	F (mm)		R.T. (kN)	R.C. (kN)	R.F. (kN)			
CPH2510	CLH 16M5-20	25	0,016	16	21		20	M5	4	6	2	20	1,2			
CPH2515	CLH 16M6-20	25	0,016					M6	4	6	2	20	1,2			
CPH2520	CLH 20M5-20	25	0,019	20				20	M5	6	6	2,8	22	1,7		
CPH2525	CLH 20M6-20	25	0,018						M6	6	8	2,8	22	1,7		
CPH2530	CLH 25M5-20	20	0,022	25				20	M5	7	6	3	22	2		
CPH2535	CLH 25M6-20	20	0,022						M6	7	8	3	22	2		
CPH2540	CLH 25M8-20	20	0,021						M8	8	25	3	22	2		
CPH2545	CLH 30M6-20	20	0,026	30				20	M6	8	10	3,4	25	2,2		
CPH2550	CLH 30M8-20	20	0,025						M8	10	25	3,4	25	2,2		
CPH2555	CLH 35M6-20	20	0,031	35				20	M6	8	10	3,4	25	1,5		
CPH2560	CLH 35M8-20	20	0,030		M8		10		25	3,4	25	1,5				
CPH2565	CLH 40M6-20	10	0,034	40		20	M6	10	10	3,7	23	1,3				
CPH2570	CLH 40M8-20	10	0,033				M8	10	25	3,7	23	1,3				
CPH2575	CLH 45M6-20	10	0,037	45		20	M6	10	10	3,7	23	1,2				
CPH2580	CLH 45M8-20	10	0,036				M8	10	25	3,7	23	1,2				
CPH2585	CLH 50M6-20	10	0,040	50		20	M6	10	10	3,7	23	1				
CPH2590	CLH 50M8-20	10	0,039				M8	10	25	3,7	23	1				
CPH2610	CLH 30M8-30	10	0,050	30		30	30	M8	10	25	6	48	4,5			
CPH2615	CLH 35M8-30	10	0,058					M8	10	25	6	50	4			
CPH2620	CLH 40M8-30	10	0,069					M8	10	25	6,5	52	3,5			
CPH2625	CLH 45M8-30	10	0,101					M8	16	25	7	55	2,8			
CPH2630	CLH 50M6-30	10	0,110					50		30	M6	16	10	7	55	2
CPH2635	CLH 50M8-30	10	0,108								M8	16	25	8	55	2,2
CPH2640	CLH 55M6-30	10	0,117					55		30	M6	16	10	8	50	1,8
CPH2645	CLH 55M8-30	10	0,115								M8	16	25	8	50	2
CPH2650	CLH 65M6-30	10	0,131					65		30	M6	16	10	8	47	1,7
CPH2655	CLH 65M8-30	10	0,120								M8	16	25	7	47	1,7
CPH2660	CLH 70M6-30	10	0,138	70		30	M6	16	10	7	45	1,5				
CPH2665	CLH 70M8-30	10	0,136				M8	16	25	7	45	1,5				

Threaded studs for insulators cf. page 62

Type: = 6 sides

*Recommended torque values for screws of strength class 8.8

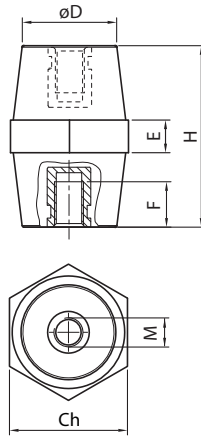

TECHNICAL CHARACTERISTICS

- Insulation:**
- Material:** Polyamide 6.6 reinforced with 35% fiberglass
- Color:** black
- Self-extinguishing:** UL 94-V0
Halogen free
- Threaded inserts:**
Galvanized steel
- Finished product:**
Rated voltage: 1000 V AC/1500 V DC
- Working temperature: $-40^{\circ}\text{C} \div +125^{\circ}\text{C}$

R.T. = Tensile strength

R.C. = Compressive strength

R.F. = Flexural strength

Code	Reference		Weight (kg)	H (mm)	Ch (mm)	Type	øD (mm)	E (mm)	M	F (mm)	(Nm)*	R.T. (kN)	R.C. (kN)	R.F. (kN)
ISO2000	ISO 15M4 UL	50	0,005	15	14	●	12	3	M4	4	3	1,5	15	1
ISO2005	ISO 20M4 UL	50	0,011	20	17	●	15	4	M4	4	3	2	20	1
ISO2007	ISO 20M5 UL	50	0,011						M5	5	6	2	20	1,5
ISO2010	ISO 20M6 UL	50	0,011	25	20	●	17	5	M6	5	8	2,5	20	2
ISO2015	ISO 25M5 UL	50	0,013						M5	5	6	4	25	2
ISO2020	ISO 25M6 UL	50	0,012	30	20	●	26	6	M6	5	10	4	25	2
ISO2025	ISO 30M6 UL	50	0,038						M6	9	10	8	75	5
ISO2030	ISO 30M8 UL	50	0,035	35	30	●	28	7	M8	9	25	8	75	5
ISO2035	ISO 35M6 UL	50	0,049						M6	11	10	9	65	5,7
ISO2040	ISO 35M8 UL	50	0,050	40	32	●	35	10	M8	9	25	9	65	5,7
ISO2045	ISO 35M10 UL	50	0,058						M10	11	50	9	65	5,7
ISO2046	ISO 35M8W UL	25	0,109	45	40	●	40	12	M8	11	25	11	110	6,5
ISO2048	ISO 35M10W UL	25	0,108						M10	11	50	11	110	6,5
ISO2050	ISO 40M6 UL	25	0,056	40	32	●	28	8	M6	11	10	13	75	5
ISO2055	ISO 40M8 UL	25	0,065						M8	11	25	13	75	5
ISO2060	ISO 40M10 UL	25	0,063	45	46	●	40	12	M10	11	50	13	75	5
ISO2061	ISO 40M8W UL	25	0,108						M8	11	25	15	120	6
ISO2063	ISO 40M10W UL	25	0,108	45	41	●	33	10	M10	11	50	15	120	6
ISO2065	ISO 45M6 UL	25	0,108						M6	15	10	16	90	6,5
ISO2070	ISO 45M8 UL	25	0,097	50	50	●	41	10	M8	15	25	16	90	6,5
ISO2075	ISO 45M10 UL	25	0,097						M10	15	50	18	90	7
ISO2076	ISO 45M8W UL	25	0,132	50	36	●	29	11	M8	15	25	20	140	8
ISO2078	ISO 45M10W UL	25	0,132						M10	15	50	20	140	8
ISO2080	ISO 50M6 UL	25	0,094	50	50	●	40	12	M6	15	10	15	100	4
ISO2085	ISO 50M8 UL	25	0,096						M8	15	25	16	100	4,5
ISO2090	ISO 50M10 UL	25	0,093	50	50	●	40	12	M10	15	50	18	100	6,5
ISO2091	ISO 50M10W UL	25	0,145						M10	15	50	20	130	7,5
ISO2093	ISO 50M12W UL	25	0,145	60	54	●	42	12	M12	15	85	20	130	8,5
ISO2094	ISO 55M10 UL	10	0,185						M10	15	50	22	150	10
ISO2095	ISO 60M8 UL	10	0,194	70	65	●	50	13	M8	15	25	22	150	9
ISO2100	ISO 60M10 UL	10	0,190						M10	15	50	22	150	9
ISO2101	ISO 70M10 UL	10	0,335	75	50	●	35	12	M10	15	50	22	180	9
ISO2103	ISO 70M12 UL	10	0,331						M12	25	85	25	180	12
ISO2105	ISO 75M12 UL	10	0,203	80	65	●	50	14	M12	25	85	20	120	7,5
ISO2110	ISO 75M16 UL	10	0,246						M16	25	200	20	120	7,5
ISO2112	ISO 80M12 UL	10	0,370	100	65	●	50	21	M12	25	85	25	180	12
ISO2115	ISO 100M12 UL	10	0,458						M12	25	85	30	200	10
ISO2117	ISO 100M16 UL	10	0,430	M16	25	200	30	200	10					

Threaded studs for insulators cf. page 62

Type: ● = 6 sides ● = 8 sides

*Recommended torque values for screws of strength class 8.8



file n° 300607

TECHNICAL CHARACTERISTICS

Insulation:

Material: Polyamide 6.6 reinforced with 35% fiberglass

Color: black

Halogen free

Self-extinguishing: UL 94-V0

Threaded inserts:

Galvanized steel

Finished product:

Rated voltage: 1000 V AC/1500 V DC

Working temperature: $-40^{\circ}\text{C} \div +125^{\circ}\text{C}$

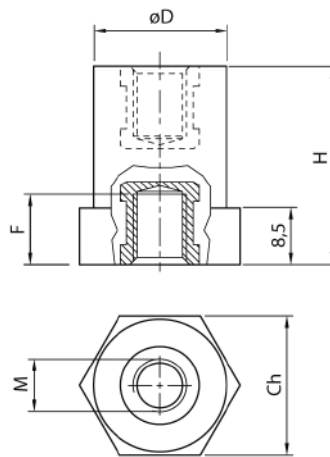

R.T. = Tensile strength

R.C. = Compressive strength

R.F. = Flexural strength

Code	Reference		Weight (kg)	H (mm)	Ch (mm)	Type	øD (mm)	M	F (mm)	$\left(\frac{\text{Nm}}{\text{mm}}\right)^*$	R.T. (kN)	R.C. (kN)	R.F. (kN)
ISO2120	CLN 16M4-20	50	0,014	16	21	●	20	M4	4	3	2	42	1
ISO2125	CLN 16M5-20	50	0,014					M5	5	6	3	42	1,5
ISO2130	CLN 16M6-20	50	0,014					M6	5	6	3,5	42	1,5
ISO2135	CLN 20M5-20	50	0,015	20	21	●	20	M5	5	6	4	45	2
ISO2140	CLN 20M6-20	50	0,015					M6	5	8	4,5	45	2,8
ISO2145	CLN 25M4-20	50	0,016	25	21	●	20	M4	4	3	3	47	1,5
ISO2150	CLN 25M5-20	50	0,017					M5	5	6	4	47	2
ISO2155	CLN 25M6-20	50	0,018					M6	5	8	5,5	47	3,5
ISO2160	CLN 25M8-20	50	0,018	30	21	●	20	M8	5	25	5,5	47	3,5
ISO2165	CLN 30M5-20	50	0,027					M5	9	6	7	50	3,7
ISO2170	CLN 30M6-20	50	0,026					M6	9	10	7	50	3,7
ISO2175	CLN 30M8-20	50	0,024	35	21	●	20	M8	9	25	7	50	3,7
ISO2180	CLN 35M5-20	50	0,030					M5	9	6	7	50	3,5
ISO2185	CLN 35M6-20	50	0,029					M6	9	10	8	50	3,5
ISO2190	CLN 35M8-20	50	0,026	40	21	●	20	M8	9	25	8	50	3,5
ISO2195	CLN 40M5-20	50	0,030					M5	9	6	8	50	3
ISO2200	CLN 40M6-20	50	0,030					M6	9	10	8	50	3
ISO2205	CLN 40M8-20	50	0,028	45	21	●	20	M8	9	25	8	50	3
ISO2210	CLN 45M5-20	25	0,033					M5	9	6	8	47	2,6
ISO2215	CLN 45M6-20	25	0,031					M6	9	10	8	47	2,6
ISO2220	CLN 45M8-20	25	0,030	50	21	●	20	M8	9	25	8	47	2,6
ISO2225	CLN 50M5-20	25	0,032					M5	9	6	8	45	2,2
ISO2230	CLN 50M6-20	25	0,034					M6	9	10	8	45	2,2
ISO2235	CLN 50M8-20	25	0,033	30	30	●	30	M8	9	25	8	45	2,2
ISO2240	CLN 30M6-30	50	0,039					M6	11	10	10	70	5
ISO2245	CLN 30M8-30	50	0,037					M8	9	25	12	80	5,5
ISO2250	CLN 35M6-30	50	0,041	35	30	●	30	M6	11	10	11	75	5
ISO2255	CLN 35M8-30	50	0,039					M8	11	25	14	85	5,5
ISO2256	CLN 40M6-30	25	0,061	40	30	●	30	M6	11	10	11	75	4,5
ISO2257	CLN 40M8-30	25	0,061					M8	11	25	14	85	4,8
ISO2260	CLN 45M6-30	25	0,082	45	30	●	30	M6	15	10	12	90	4,2
ISO2265	CLN 45M8-30	25	0,078					M8	15	25	16	90	4,2
ISO2266	CLN 50M6-30	25	0,087	50	30	●	30	M6	15	10	12	80	3,8
ISO2267	CLN 50M8-30	25	0,083					M8	15	25	16	80	3,8
ISO2270	CLN 55M6-30	25	0,094	55	30	●	30	M6	15	10	11	75	3,5
ISO2275	CLN 55M8-30	25	0,091					M8	15	25	13	75	3,5
ISO2280	CLN 65M6-30	25	0,104	65	30	●	30	M6	15	10	9,5	70	3
ISO2285	CLN 65M8-30	25	0,104					M8	15	25	9,5	70	3
ISO2290	CLN 70M6-30	25	0,109	70	30	●	30	M6	15	10	9	65	2,8
ISO2295	CLN 70M8-30	25	0,098					M8	15	25	9	65	2,8

Threaded studs for insulators cf. page 62

Type: ● = 6 sides

*Recommended torque values for screws of strength class 8.8

PRODUCTS CONFORMING TO REGULATIONS



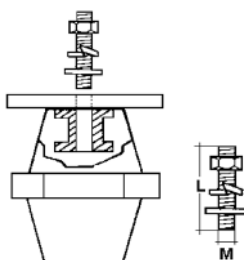

TECHNICAL CHARACTERISTICS

Material: Made of galvanized steel class 8.8
 Complete with nut, flat washer
 and anti-loosening washer
 Threaded studs with hexagonal socket,
 to be tightened with Allen wrenches

THREADED PINS FOR CPH AND ISO SERIES INSULATORS

Code	Reference		M	L
ISO3000	ISO PM5x20	25	M5	20
ISO3005	ISO PM6x30	25	M6	30
ISO3010	ISO PM8x30	25	M8	30
ISO3015	ISO PM8x35	25	M8	35
ISO3020	ISO PM10x40	25	M10	40
ISO3025	ISO PM12x50	25	M12	50

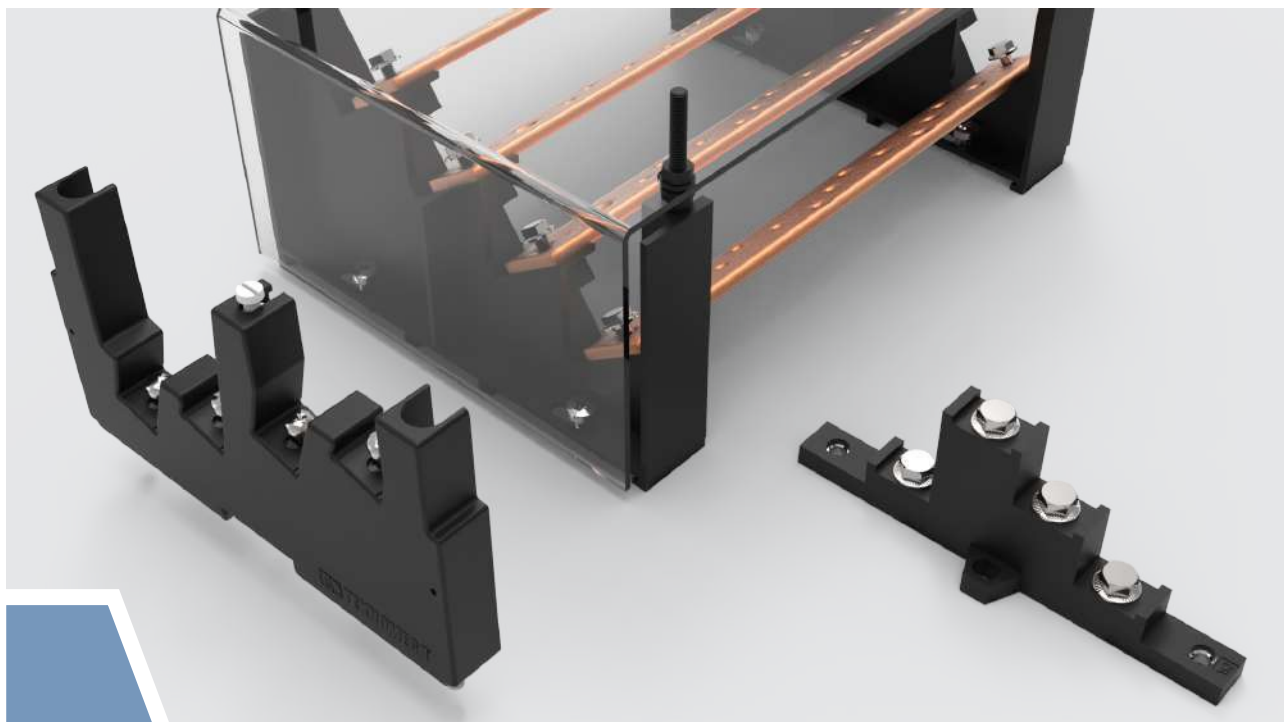

Distribution Supports allow current derivations to be made by separating phases and multiplying connections, inside equipment and electrical panels, with direct fastening on the electrical panel carpentry and on DIN rails

TECHNICAL CHARACTERISTICS

Material: Polyamide 6,6 reinforced with fiberglass

Color: black

Self-extinguishing: UL 94-V0

Working temperature: -40 °C ÷ +130 °C

M6 screws included for busbar fixing for PSP1000 and PSP1005
Kit for the mounting of protection screen included for PSP1000, PSP1002 and PSP1005

Direct mounting on DIN rail for PSP1002

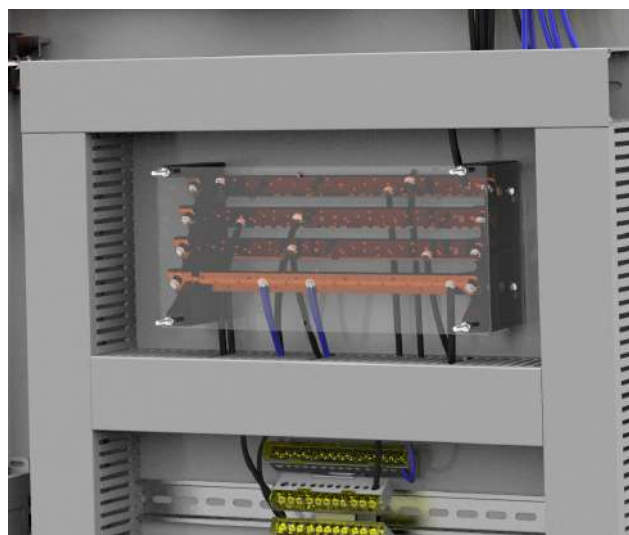
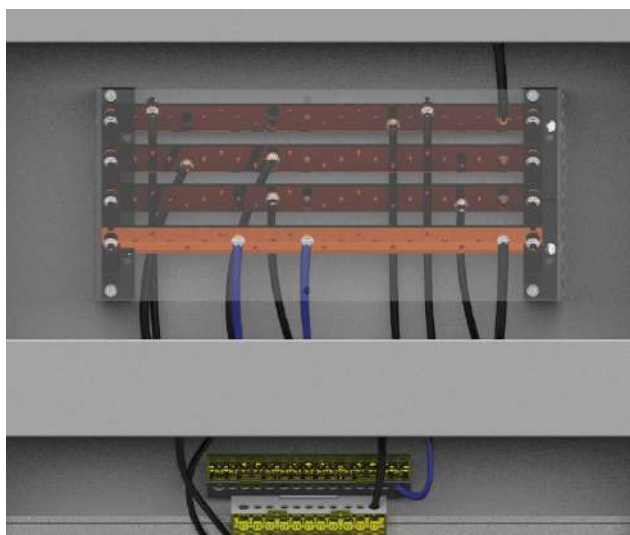

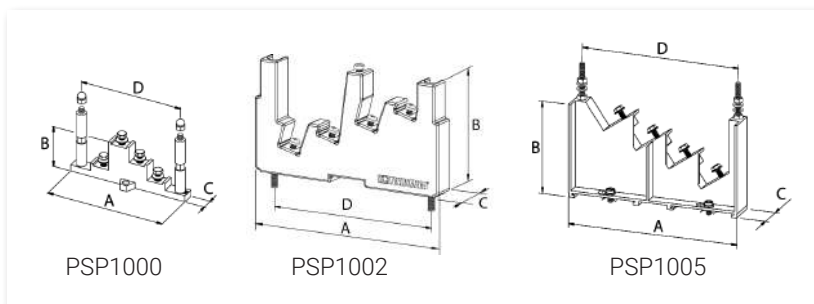

TECHNICAL CHARACTERISTICS

Material: Polyamide 6.6 reinforced with 30% fiberglass

Color: black

Self-extinguishing: UL 94-V0

Working temperature:

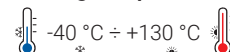

DISTRIBUTION BLOCKS SUPPORTS

Code	Reference		Type	A (mm)	B (mm)	C (mm)	D (mm)
PSP1000	PSP 250	8	T+N	150	54	15	130
PSP1002	PSP 250 HP	1	T+N	190	104.5	20	162.5
PSP1005	PSP 400	2	T+N	216	117	34	200

Code	Sect. Bar	lcc pk (kA)	11.9	13.6	24	30	48.3
		lcc rms (kA)	7	8	12	15	23
		In (A)	Distance (mm)				
PSP1000	15x5	160	560	450	250	150	-
	20x5	250	640	520	260	150	-
PSP1002	15x5	160	630	550	320	210	-
	20x5	250	730	630	320	210	-
PSP1005	15x5	160	680	550	310	250	100
	20x5	250	780	640	360	260	100
	32x5	400	980	800	410	260	100
	20x10	500	980	980	410	260	100
	30x10	630	980	980	410	260	100

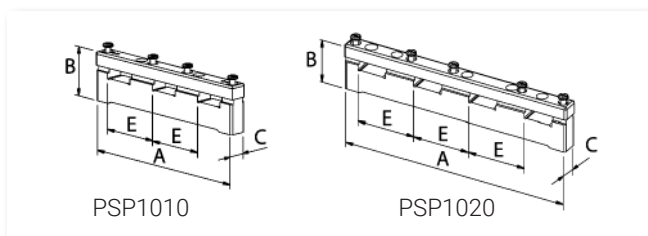

TECHNICAL CHARACTERISTICS

Material: Polyamide 6.6 reinforced with 25% fiberglass

Color: black

Self-extinguishing: UL 94-V0

Working temperature:

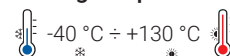

DISTRIBUTION BLOCKS SUPPORTS

Code	Reference		Type	A (mm)	B (mm)	C (mm)	E (mm)
PSP1010	PSP 630T	1	T	180	55	18	60
PSP1020	PSP 630TN	1	T+N	240	55	18	60

Code	Sect. Bar	lcc pk (kA)	30	34	44.1	50.4	54.6	60.9	75.6
		lcc rms (kA)	15	17	21	24	26	29	36
		In (A)	Distance (mm)						
PSP1010	20x5	250	600		400		200*		
	20x10	500		600		400		200*	
PSP1020	30x5	400			600			400	200*
	30x10	630			600			400	200

Distance between supports depending on lcc (short-circuit current)

lcc pk = Short-circuit current peak value expressed in kA

lcc rms = Effective value of short-circuit current, duration equal to 1 second, expressed in kA

*lcc rms = Effective value of short-circuit current, duration equal to 0.4 seconds, expressed in kA

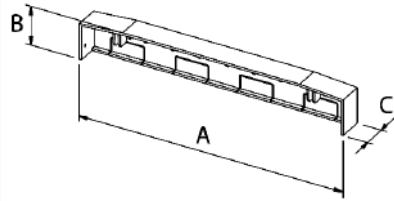

TECHNICAL CHARACTERISTICS

Material: PA 6
Self-extinguishing: UL 94-V0
 Halogen free
Working temperature: $-40^{\circ}\text{C} \div +120^{\circ}\text{C}$

PROTECTION CAPS

Code	Reference		Type	A (mm)	B (mm)	C (mm)
PSP1015	PSP PRO 630T	1	For support PSP1010	185	36	23
PSP1025	PSP PRO 630TN	1	For support PSP1020	245	36	23

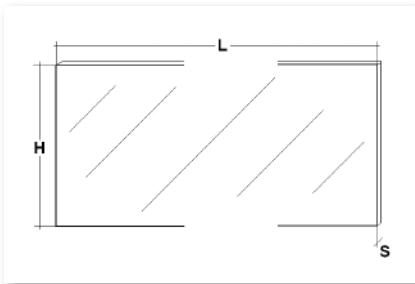

TECHNICAL CHARACTERISTICS

Material: made of PETG (polyethylene terephthalate), transparent
 Dielectric strength: 16 kV/mm
 Halogen free
Self-extinguishing: UL 94-HB
Minimum bend radius: 1 mm at 90°
Maximum working temperature: $+65^{\circ}\text{C}$

COLD BENDABLE PROTECTION SCREEN

Code	Reference		Weight (kg)	H (mm)	L (mm)	S (mm)
SCH1000	SCH 1000x2000x3	1	7.00	1000	2000	3
SCH1005	SCH 1000x215x3	5	0.75	1000	215	3
SCH1010	SCH 1000x150x3	5	0.53	1000	150	3

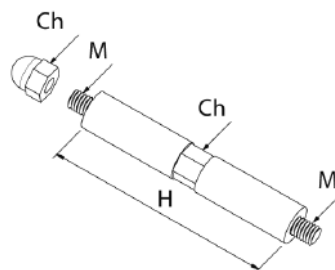

TECHNICAL CHARACTERISTICS

Material: Polyamide 6.6 with fiberglass, black color
Self-extinguishing: UL 94-V0
The KIT is made of:
 No. 4 threaded spacers male / male M6
 No. 4 female threaded caps M6

PLASTIC SPACER SUPPORT FOR PROTECTION SCREEN

Code	Reference		Type	H (mm)	(m)	Ch (mm)
DZP2000	DZP KIT	10	For support PSP1000	70	M6	10

Distribution Block supports in KIT form include all that is needed to make the distribution.

The KIT is made of:

- Copper bars (cross-section, length and nr. of holes as per below table)
- Distribution supports
- Support spacers for the protection screen
- Protection screen cut, bent and punched in the suitable dimensions
- Hardware

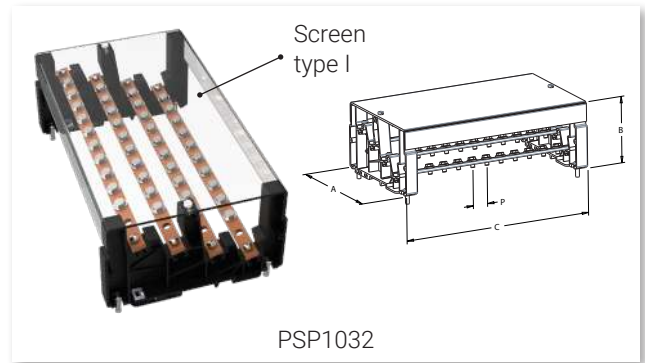
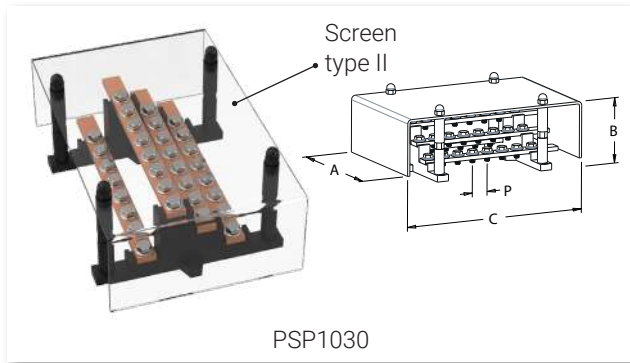

DISTRIBUTION SUPPORTS IN KIT 160 A

Code	Reference		In (A)	Icc rms (kA)	Sect. Bar	A	B	C	P	Number of		No. Supports
						(mm)				INPUT	OUTPUT	
PSP1030	PSP 160K-23	1	160	15	15 x 5	150	81	230	20	1 x Ø 8,5	6 x M6	2 x PSP1000
PSP1032	PSP 160K-32	1	160	10	15 x 5	190	108	320	25	1 x Ø 8,5	10 x M6	2 x PSP1002

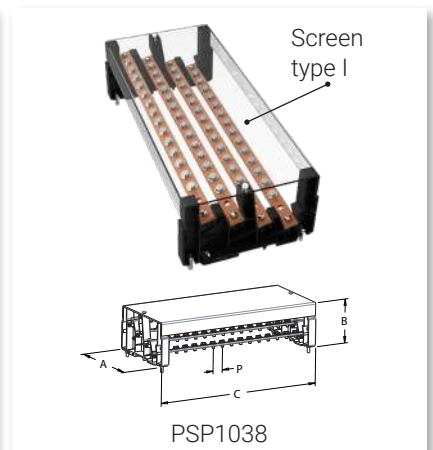
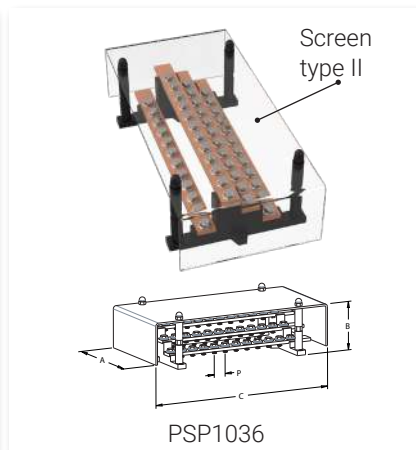
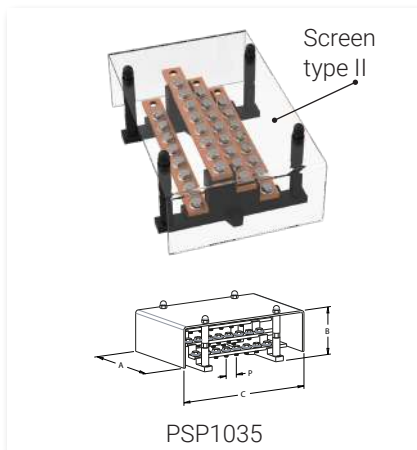

DISTRIBUTION SUPPORTS IN KIT 250 A

Code	Reference		In (A)	Icc rms (kA)	Sect. Bar	A	B	C	P	Number of		No. Supports
						(mm)				INPUT	OUTPUT	
PSP1035	PSP 250K-23	1	250	15	20 x 5	150	81	230	20	1 x Ø 8,5	6 x M6	2 x PSP1000
PSP1036	PSP 250K-31	1	250	12	20 x 5	150	81	310	20	1 x Ø 8,5	10 x M6	2 x PSP1000
PSP1038	PSP 250K-42	1	250	10	20 x 5	190	108	420	25	1 x Ø 8,5	14 x M6	2 x PSP1002

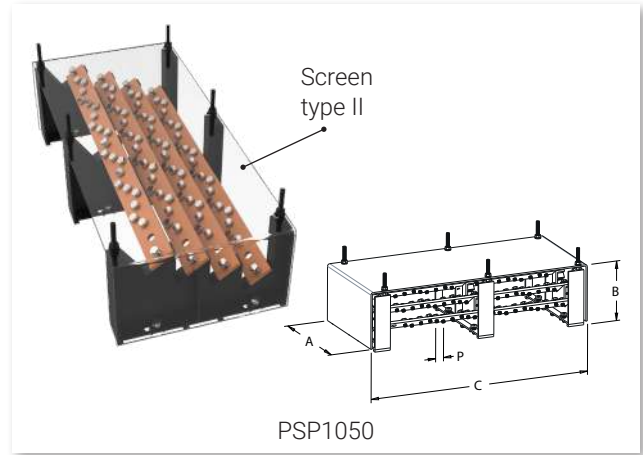
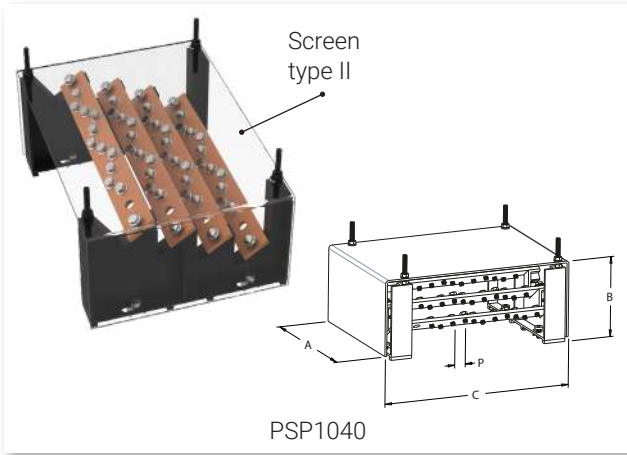

DISTRIBUTION SUPPORTS IN KIT 400 A

Code	Reference		In (A)	Icc rms (kA)	Sect. Bar	A	B	C	P	Number of		No. Supports
						(mm)				INPUT	OUTPUT	
PSP1040*	PSP 400K-30	1	400	15	32 x 5	216	127	305	17,5-W	1 x Ø 10,5	11 x M6	2 x PSP1005
PSP1050*	PSP 400K-48	1	400	16	32 x 5	216	127	480	17,5-W	1 x Ø 10,5	20 x M6	3 x PSP1005

* Kit includes BRF1041 (see page).

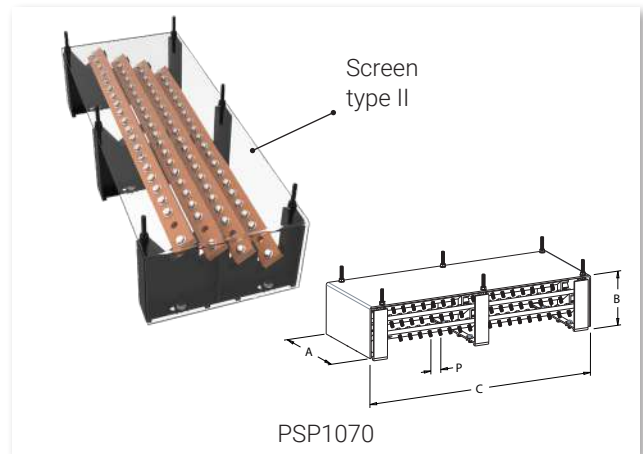
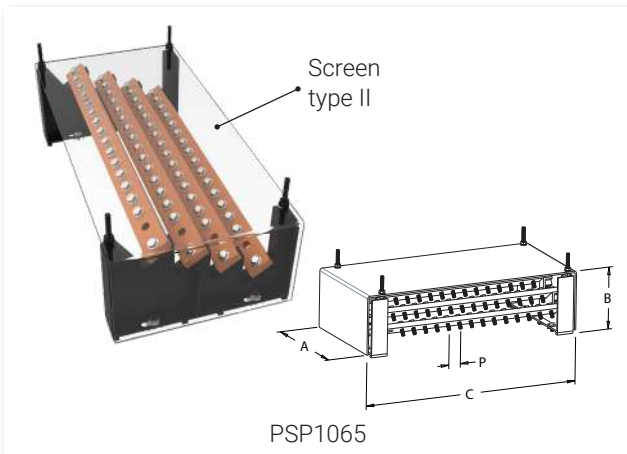

DISTRIBUTION SUPPORTS IN KIT 630 A

Code	Reference		In (A)	Icc rms (kA)	Sect. Bar	A	B	C	P	Number of		No. Supports
						(mm)				INPUT	OUTPUT	
PSP1065	PSP 630K-45	1	630	12	30 x 10	216	127	455	25	1 x Ø 10,5	14 x M8	2 x PSP1005
PSP1070	PSP 630K-55	1	630	15	30 x 10	216	127	555	25	1 x Ø 10,5	17 x M8	3 x PSP1005

The power inputs of the KIT distribution supports can be positioned both on the right and on the left side.

Screens caption

- Type I: Front screen with top/bottom flaps
- Type II: Front and side screen

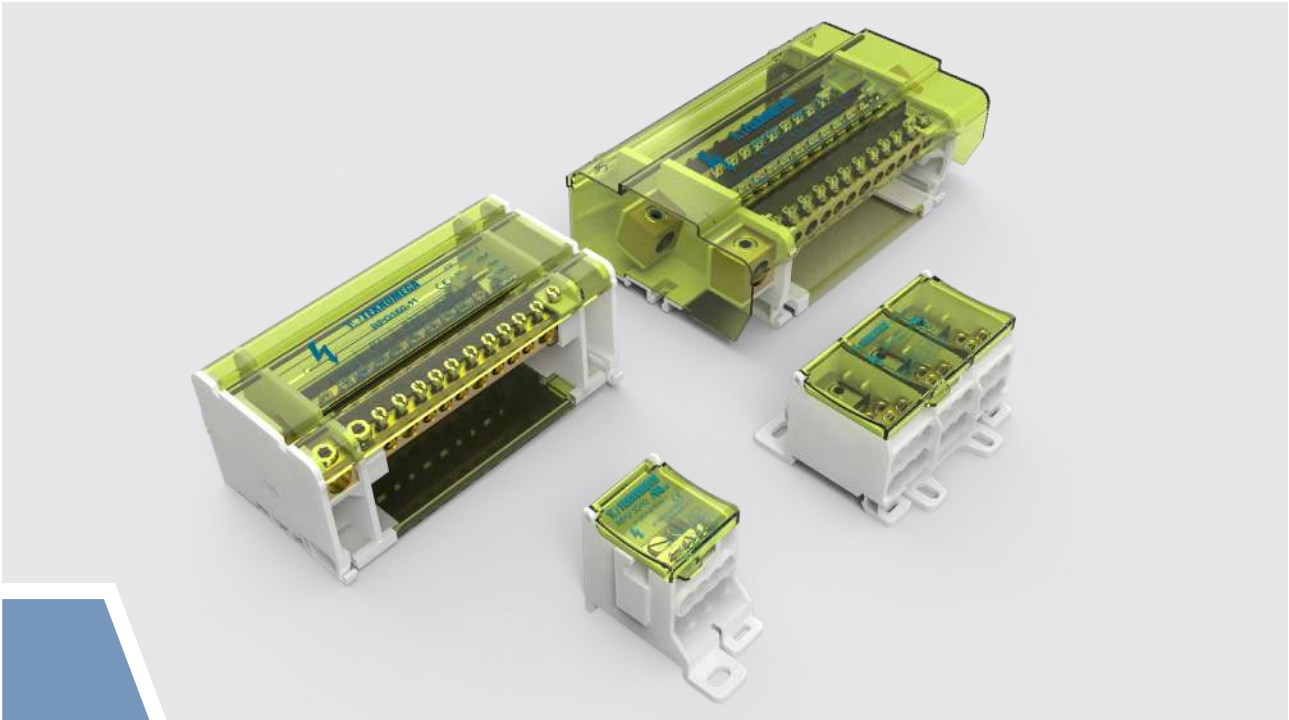

The **TEKNOMEGA** Ω block is a complete range of distribution blocks, from one to four pole. This allows making distribution units from 40 A up to 500 A.

Two and four pole distribution blocks: from 40 A up to 400 A.

Equipped with a transparent protection screen between phases, at the front and bottom of the distribution block, removable to tighten connections. Recently introduced the **4-pole Modular Up & Down Distribution Block** from **160 A**, these allow the user to simply manage situations where the installer must satisfy articulated mounting needs contained in the dimensions, for example when there are too many wiring inputs and outputs to be placed on one side of the block.

The **new 4-pole Side Input Distribution Block** from **160 A** makes it possible to connect directly to the switch.

Single pole and three pole distribution blocks: from 80 A up to 500 A. Registered as per UL standard. Wiring is made easy by guided accesses. High electrical insulation value. No protection to remove to tighten the connections.

Quick distribution blocks: 63 A, 1 and 2 pole. Quick indirect spring hook-up outputs, efficient and safe.

All the Ω BLOCK distribution blocks range can be fit on DIN profile ("Ω" rail) and/or bottom plate using the specific provisions.



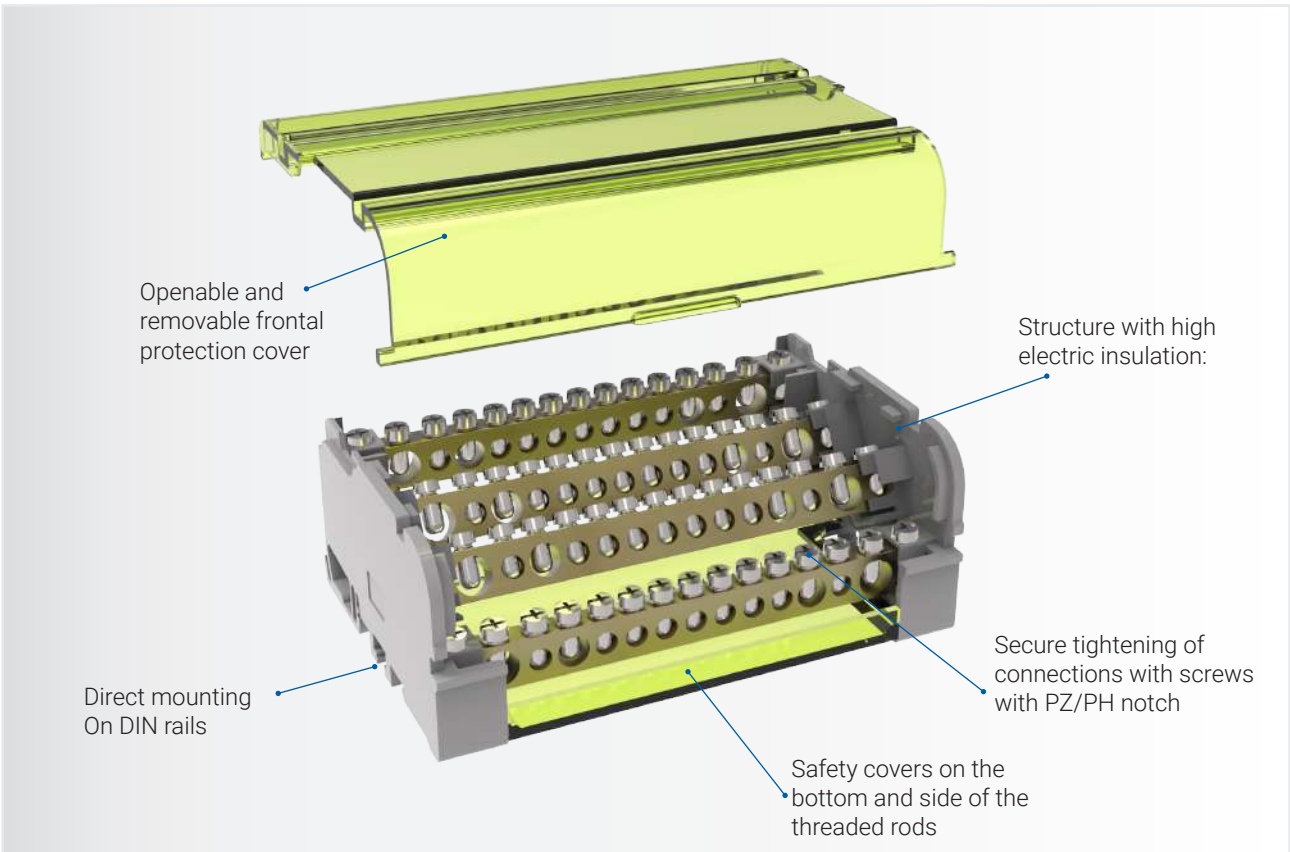
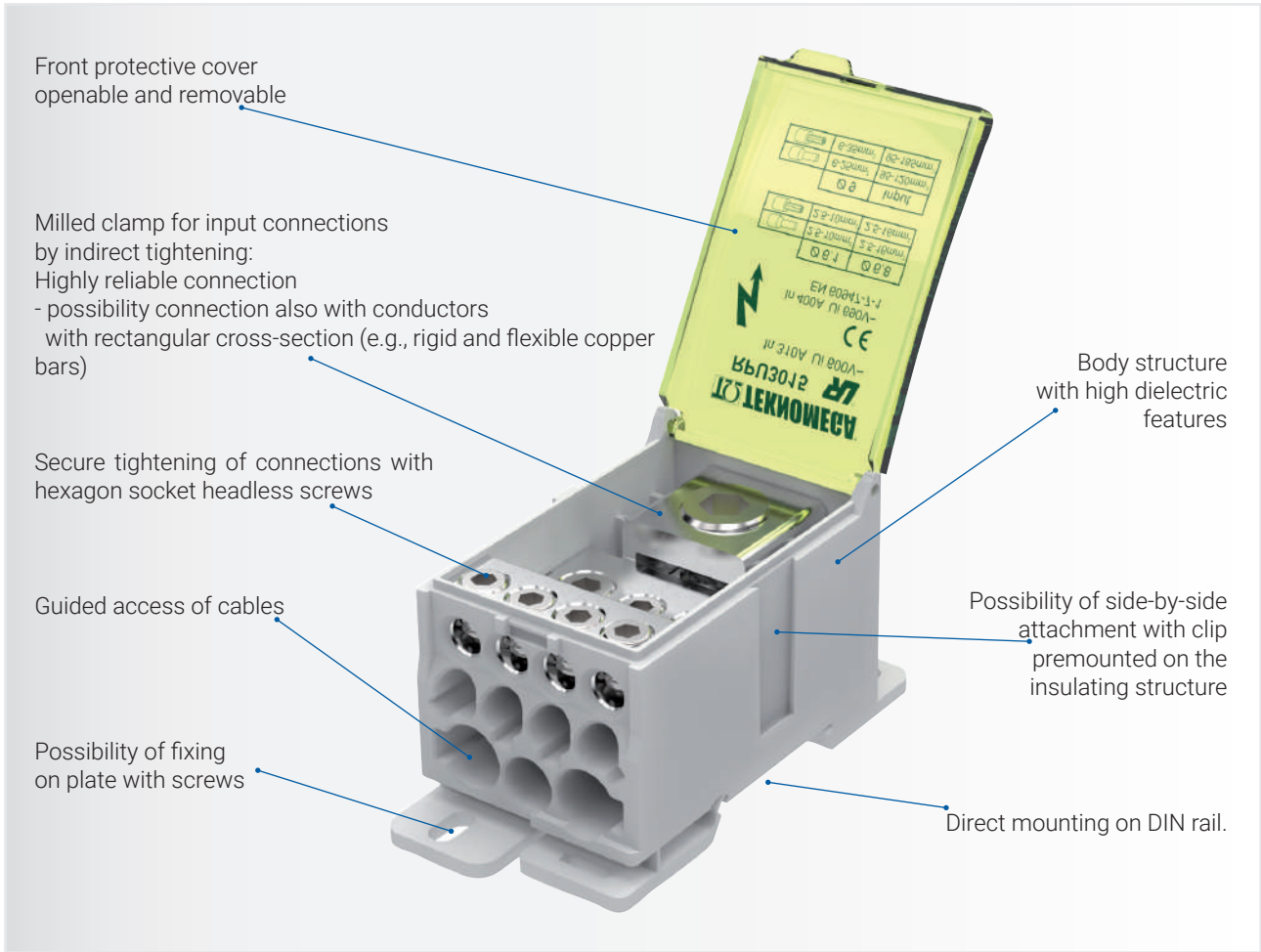

Ω BLOCK - Two pole distribution blocks

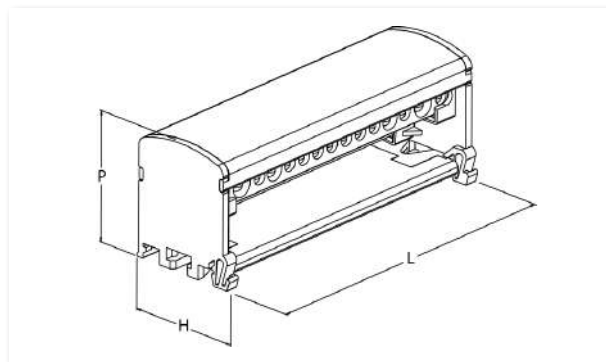

TECHNICAL CHARACTERISTICS

Insulating block: PA 6, UL 94-V0, grey RAL 7035

Protective screen: PC, UL 94-V2, transparent yellow, manually removable

Conduction block: brass

Screws: steel

IP10 degree of protection, provides protection in case of accidental contact

Quick hook-up on DIN rails

Compliant with standard EN 60947-7-1

RPB0990 and RPB0995

- Maximum continuous operation temperature is: +85 °C

RPB1000 and RPB1005

- Maximum continuous operation temperature is: +105 °C
- Halogen-free

2-POLE DIVIDERS - RPB

Code	Reference		Weight (kg)	L (mm)	H (mm)	P (mm)	Hole spacing fixing (mm)
RPB0990	RPB 40-08	1	0,082	66	46	51	45
RPB0995	RPB 80-07	1	0,108	66	46	51	45
RPB1000	RPB 125-06	1	0,102	66	46	51	45
RPB1005	RPB 125-14	1	0,200	132	46	51	112

TECHNICAL DATA

Code	Type	In (A)	IN/OUT	Sect. (mm ²)	Sect. (mm ²)	Nr	∅ (mm)	I _{cw} (kA)	I _{pk} (kA)	U _i (V)
RPB0990	2-POLE 8 outputs	40	IN →	2,5 ÷ 6	1,5 ÷ 6	1	5,5	2,0	15	1000
			← OUT	2,5 ÷ 6	1,5 ÷ 6	1	5,5			
			← OUT	1,5 ÷ 4	1,5 ÷ 4	4	4			
			← OUT	1,5 ÷ 2,5	1,5 ÷ 2,5	3	3			
RPB0995	2-POLE 7 outputs	80	IN →	10 ÷ 25	6 ÷ 16	1	7,5	4,5	20	1000
			← OUT	1,5 ÷ 4	1,5 ÷ 4	5	4,5			
			← OUT	1,5 ÷ 4	1,5 ÷ 4	2	5			
RPB1000	2-POLE 6 outputs	125	IN →	10 ÷ 35	10 ÷ 25	1	9,0	4,2	20	1000
			← OUT	2,5 ÷ 6	1,5 ÷ 6	5	5,5			
			← OUT	10 ÷ 25	6 ÷ 16	1	7,5			
RPB1005	2-POLE 14 outputs	125	IN →	10 ÷ 35	10 ÷ 25	1	9,0	4,2	20	1000
			← OUT	10 ÷ 35	10 ÷ 25	1	9,0			
			← OUT	2,5 ÷ 6	1,5 ÷ 6	11	5,5			
			← OUT	10 ÷ 25	6 ÷ 16	2	7,5			

I_{cc pk} = Short-circuit current peak value expressed in kA

I_{cw} = Effective value of short-circuit current, duration equal to 1 second, expressed in kA as per standard EN 60947-7-1

U_i = Nominal insulation voltage

Cables legend:

Stripped wire

Cable with ferrule

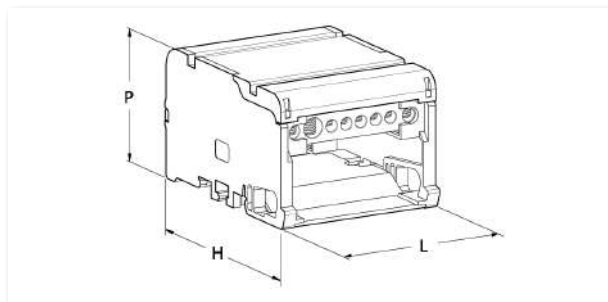

TECHNICAL CHARACTERISTICS

Insulating block: PA 6, UL 94-V0, halogen-free, RAL 7035 gray

Protective screen: PC, UL 94-V2, transparent yellow, manually removable

Conduction block: brass

Screws: steel

IP10 degree of protection, provides protection in case of accidental contact

Quick hook-up on DIN rails

Compliant with standard EN 60947-7-1

**RPQ0980, RPQ0985,
RPQ0990 and RPQ0995**

- Maximum temperature of continuous operation: +85 °C

RPQ1000, RPQ1005 and RPQ1010

- Maximum temperature of continuous operation: +105 °C
- Halogen-free

4-POLE DISTRIBUTION BLOCKS - RPQ

Code	Reference		Weight (kg)	L (mm)	H (mm)	P (mm)	Hole spacing fixing (mm)
RPQ0980	RPQ 40-08	1	0,165	66	84	50	45
RPQ0985	RPQ 40-14	1	0,245	100	84	50	80
RPQ0990	RPQ 80-07	1	0,214	66	84	50	45
RPQ0995	RPQ 80-12	1	0,319	100	84	50	80
RPQ1000	RPQ 125-06	1	0,200	66	84	50	45
RPQ1005	RPQ 125-10	1	0,300	100	84	50	80
RPQ1010	RPQ 125-14	1	0,400	132	84	50	112

TECHNICAL DATA

Code	Type	In (A)	IN/OUT	Sect. (mm ²)	Sect. (mm ²)	Nr	Ø (mm)	I _{cc} (kA)	I _{pk} (kA)	U _i (V)
RPQ0980	4-POLE 8 outputs	40	IN →	2.5 ÷ 6	1.5 ÷ 6	1	5.5	2	15	1000
			← OUT	2.5 ÷ 6	1.5 ÷ 6	1	5.5			
			← OUT	1.5 ÷ 4	1.5 ÷ 4	4	4			
			← OUT	1.5 ÷ 2.5	1.5 ÷ 2.5	3	3			
RPQ0985	4-POLE 14 outputs	40	IN →	2.5 ÷ 6	1.5 ÷ 6	1	5.5	2	15	1000
			← OUT	2.5 ÷ 6	1.5 ÷ 6	1	5.5			
			← OUT	1.5 ÷ 4	1.5 ÷ 4	7	4			
			← OUT	1.5 ÷ 2.5	1.5 ÷ 2.5	6	3			
RPQ0990	4-POLE 7 outputs	80	IN →	10 ÷ 25	6 ÷ 16	1	7.5	4.5	20	1000
			← OUT	1.5 ÷ 4	1.5 ÷ 4	5	4.5			
			← OUT	1.5 ÷ 4	1.5 ÷ 4	2	5			
RPQ0995	4-POLE 12 outputs	80	IN →	10 ÷ 25	6 ÷ 16	1	7.5	4.5	20	1000
			← OUT	10 ÷ 25	6 ÷ 16	1	7.5			
			← OUT	1.5 ÷ 4	1.5 ÷ 4	8	4.5			
			← OUT	1.5 ÷ 4	1.5 ÷ 4	2	5			
			← OUT	4 ÷ 10	2.5 ÷ 6	1	6			
RPQ1000	4-POLE 6 outputs	125	IN →	10 ÷ 35	10 ÷ 25	1	9	4.2	18	1000
			← OUT	2.5 ÷ 10	1.5 ÷ 10	5	5.5			
			← OUT	10 ÷ 25	6 ÷ 16	1	7.5			
RPQ1005	4-POLE 10 outputs	125	IN →	10 ÷ 35	10 ÷ 25	1	9	4.2	18	1000
			← OUT	10 ÷ 35	10 ÷ 25	1	9			
			← OUT	10 ÷ 25	6 ÷ 16	2	7.5			
			← OUT	2.5 ÷ 10	1.5 ÷ 10	7	5.5			
RPQ1010	4-POLE 14 outputs	125	IN →	10 ÷ 35	10 ÷ 25	1	9	4.2	18	1000
			← OUT	10 ÷ 35	10 ÷ 25	1	9			
			← OUT	10 ÷ 25	6 ÷ 16	2	7.5			
			← OUT	2.5 ÷ 10	1.5 ÷ 10	11	5.5			

I_{cc} pk = Short-circuit current peak value expressed in kA
I_{cc} = Effective value of short-circuit current, duration equal to 1 second, expressed in kA as per standard EN 60947-7-1
U_i = Nominal insulation voltage

Cables legend:

Stripped wire

Cable with ferrule

Ω BLOCK - Four pole distribution blocks

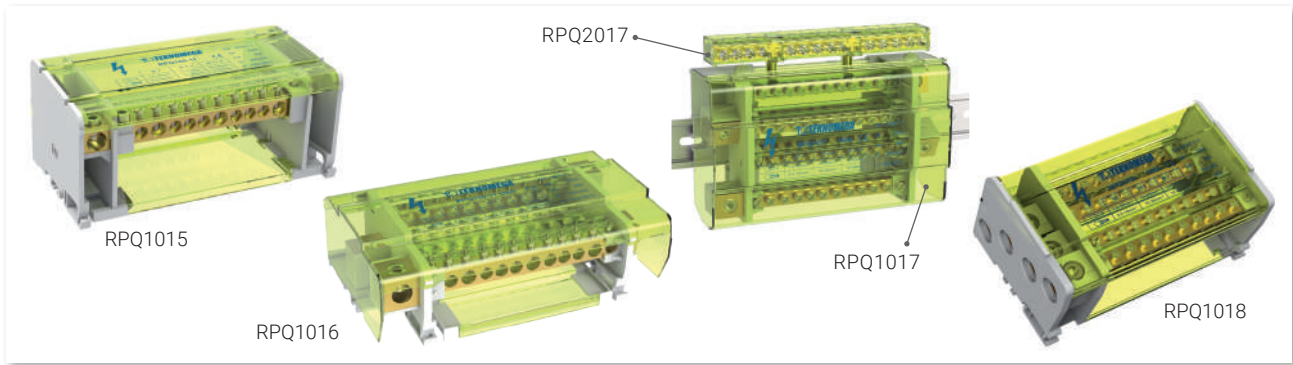

TECHNICAL CHARACTERISTICS

Insulating block: PA 6, UL 94-V0, grey RAL 7035.

Protective screen: PC, UL 94-V2, transparent yellow, manually removable

Conduction block: brass

Screws: steel

IP10 degree of protection, provides protection in case of accidental contacts

Quick hook-up on DIN rails

Compliant with standard EN 60947-7-1

RPQ1015, RPQ1016 and RPQ1017

- Maximum continuous operation temperature is: +85 °C

RPQ1018

- Maximum continuous operation temperature is: +85 °C

- Halogen-free

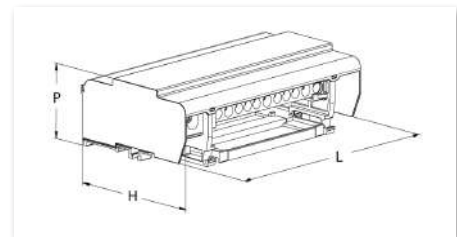

ADVANTAGES

Separate inputs

Forged conductors

Easy wiring: RPQ1015, RPQ1018

Modular depth: RPQ1016, RPQ1017

RPQ1016: Version Up & Down connection of 2 phases on each side

RPQ1018: Version Side Input orthogonal inputs to outputs

4-POLE DISTRIBUTION BLOCKS 160A - RPQ

Code	Reference		Weight (kg)	L (mm)	H (mm)	P (mm)	Hole spacing fixing (mm)
RPQ1015	RPQ 160-11	1	0,790	168	85	70	147
RPQ1016	RPQ 160-11-U&D	1	0,785	176	105	55	163
RPQ1017	RPQ 160-11 MS	1	0,780	176	105	55	163
RPQ1018	RPQ 160-11 SI	1	0,795	154	95	67	135

TECHNICAL DATA

Code	Type	In (A)	IN/OUT	Sect. (mm ²)	Sect. (mm ²)	Nr	∅ (mm)	I _{cw} (kA)	I _{pk} (kA)	U _i (V)
RPQ1015	QUADRIPOLORE 11 uscite	160	IN →	10 ÷ 50	10 ÷ 50	1	11,5	9	22	1000
			← OUT	10 ÷ 35	10 ÷ 25	3	8,5			
			← OUT	2,5 ÷ 16	1,5 ÷ 16	8	7			
RPQ1016	QUADRIPOLORE Modulare 11 uscite	160	IN →	10 ÷ 50	10 ÷ 50	1	12	9	22	1000
			← OUT	10 ÷ 35	10 ÷ 25	3	8,5			
			← OUT	2,5 ÷ 16	1,5 ÷ 16	7	7,2			
			← OUT	2,5 ÷ 10	1,5 ÷ 6	1	5,5			
RPQ1017	QUADRIPOLORE Modulare 11 uscite	160	IN →	10 ÷ 50	10 ÷ 50	1	12	9	22	1000
			← OUT	10 ÷ 35	10 ÷ 25	3	8,5			
			← OUT	2,5 ÷ 16	1,5 ÷ 16	7	7,2			
			← OUT	2,5 ÷ 10	1,5 ÷ 6	1	5,5			
RPQ1018	QUADRIPOLORE Side Input 11 uscite	160	IN →	10 ÷ 50	10 ÷ 50	1	12	9	22	1000
			← OUT	10 ÷ 35	10 ÷ 25	3	8,5			
			← OUT	2,5 ÷ 16	1,5 ÷ 16	8	7			

I_{cc pk} = Short-circuit current peak value expressed in kA

I_{cw} = Effective value of short-circuit current, duration equal to 1 second, expressed in kA as per standard EN 60947-7-1

U_i = Nominal insulation voltage

Cables legend:

Stripped wire

Cable with ferrule

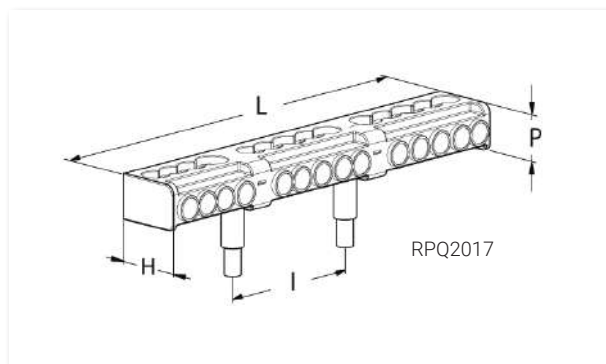
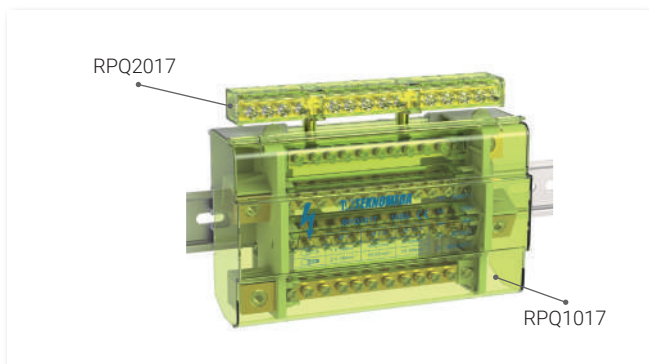

TECHNICAL CHARACTERISTICS

Insulating block: PC, UL 94-V2, transparent yellow

Conduction block: brass

Screws: steel

Protection grade IP20

Compliant with standard EN 60947-7-1

RPQ2017

- Maximum continuous operation temperature is: +85 °C 
- Halogen free



ADVANTAGES

- Improved wiring capacity
- Mechanical fastening and direct electrical connection
- Compatibility with RPQ1015, RPQ1016, RPQ1017, RPQ1018

RPQ2017

Code	Reference		Weight (kg)	L (mm)	H (mm)	P (mm)	Fixing hole spacing I (mm)
RPQ2017	RPN 160-14	1	0,190	161	27	17	57

TECHNICAL DATA

Code	Type	In (A)	IN/OUT	 Sect. (mm ²)	 Sect. (mm ²)	Nr	∅ (mm)	I _{cw} (kA)	I _{pk} (kA)	U _i (V)
RPQ2017	NEUTRAL 14 outputs	160	← OUT	10 ÷ 35	10 ÷ 16	4	8.5	9	22	1000
			← OUT	2.5 ÷ 25	10 ÷ 25	10	7			

I_{cc pk} = Short-circuit current peak value expressed in kA

I_{cw} = Effective value of short-circuit current, duration equal to 1 second, expressed in kA as per standard EN 60947-7-1

U_i = Nominal insulation voltage

Cables legend:

 Stripped wire

 Cable with ferrule



RPQ1025

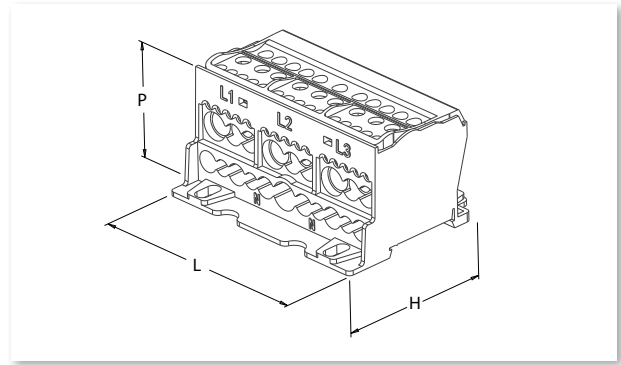

TECHNICAL CHARACTERISTICS

Insulating block: PA 6, UL 94-V0, grey RAL 7035

Protective screen: PC, UL 94-V2, transparent yellow, manually removable

Conduction block: brass

Screws: steel

Protection grade IP20

Quick hook-up on DIN rails

Compliant with standard EN 60947-7-1

RPQ1025

- Maximum continuous operation temperature is: +85 °C
- Easy wiring

ADVANTAGES

- Easy connection: inputs are separated from the outputs
- Easy inspection of the wiring cable and verification of the connections

RPQ1025

Code	Reference		Weight (kg)	L (mm)	H (mm)	P (mm)	Fixing hole spacing (mm)
RPQ1025	RPQ C-125	1	0,320	98	75	49	55 - 70

TECHNICAL DATA

Code	Type	In (A)	PHASES/NEUTRAL	IN/OUT	Sect. (mm ²)	Sect. (mm ²)	Nr	∅ (mm)	I _{cw} (kA)	I _{pk} (kA)	U _i (V)
RPQ1025	4-POLE Compact 7 outputs	125	phase	IN →	2.5 ÷ 35	1.5 ÷ 25	1	8.5	4.2	24	1000
			phase	← OUT	1.5 ÷ 16	1.5 ÷ 16	2	7			
			phase	← OUT	1.5 ÷ 6	0.5 ÷ 6	5	4.5			
			neutral	IN →	6 ÷ 35	4 ÷ 25	1	8.5			
			neutral	← OUT	1.5 ÷ 16	1.5 ÷ 16	6	7			
			neutral	← OUT	1.5 ÷ 6	0.5 ÷ 10	4	5.5			

I_{cc pk} = Short-circuit current peak value expressed in kA

I_{cw} = Effective value of short-circuit current, duration equal to 1 second, expressed in kA as per standard EN 60947-7-1

U_i = Nominal insulation voltage

Cables legend:

Stripped wire

Cable with ferrule

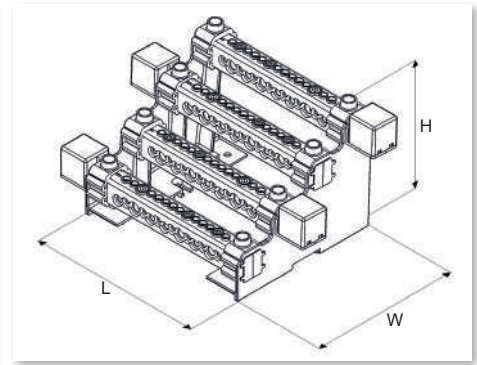
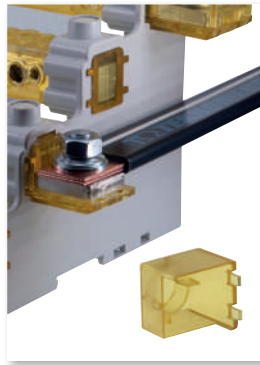

TECHNICAL CHARACTERISTICS

Supporting structure: PA 6, UL 94-V0, grey RAL 7035

Protective screen: PC, UL 94-V2, transparent yellow, manually removable

Conduction block: tinned copper

Screws: steel

IP10 degree of protection, provides protection in case of accidental contact

Easy installation on DIN rails or on panels with screws

Compliance with EN 60947-7-1

RPQ1050

- Maximum continuous operating temperature: +85 °C

- Halogen free

INPUT CONNECTIONS

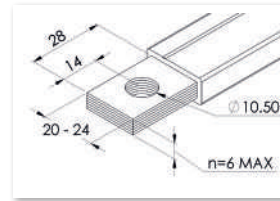

(*)COFLEX

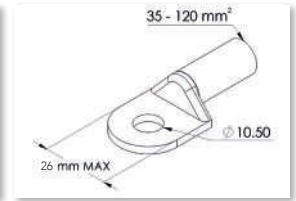

(*)Cable lugs

ADVANTAGES

Easy connection: inputs are separated from the outputs

Input connections for: COFLEX, COFLEX PLUS and cable lugs

Cable wiring on both sides with or without terminals

Easy inspection of the wiring cable and verification of the connections

RPQ1050

Code	Reference		Weight (kg)	L (mm)	H (mm)	W (mm)	Hole spacing (mm)
RPQ1050	RPQ 400 -14	1	2,073	194 (264 with terminals)	141	165	128

TECHNICAL DATA

Code	Type	In (A)	IN/OUT	Sect. (mm ²)	Sect. (mm ²)	Nr	∅ (mm)	I _{cw} (kA)	I _{pk} (kA)	U _i (V)
RPQ1050	4-POLE 14 OUTPUTS	400	IN →	35 ÷ 120 (*)	35 ÷ 120 (*)	1	28.1 x 8.2	30	53	1000
			← OUT	10 ÷ 50	10 ÷ 35	1	9.5			
			← OUT	10 ÷ 35	10 ÷ 25	2	9			
			← OUT	6 ÷ 25	6 ÷ 16	4	7			
			← OUT	2.5 ÷ 16	2.5 ÷ 10	7	5.5			

(*) Possibility to use cable lugs or COFLEX (recommended CFX size: 4x20x1 and 3x24x1)

I_{cc pk} = Short-circuit current peak value expressed in kA

I_{cw} = Effective value of short-circuit current, duration equal to 1 second, expressed in kA as per standard EN 60947-7-1

U_i = Nominal insulation voltage

Cables legend:

Stripped wire

Cable with ferrule

Ω BLOCK - Single pole distribution blocks

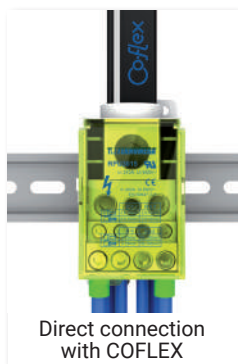

Direct connection with COFLEX

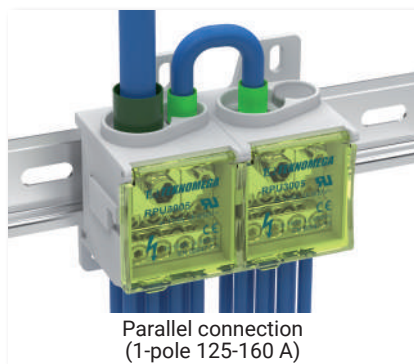

Parallel connection (1-pole 125-160 A)



CAUS file n° E302208

RPU2995

RPU3000
RPU3005

RPU3010
RPU3015

TECHNICAL CHARACTERISTICS

Insulating block: PA 6 , UL 94-V0, grey RAL 7035.

Protective screen: PC, UL 94-V2, transparent yellow, manually removable

Conduction block:

- RPU2995, RPU3000, RPU3005 and RPU3015: tinned copper

- RPU3010: brass

Screws: tin-plated steel and aluminium

Protection grade IP20B

Quick hook-up on DIN rails

Compliant with standard EN 60947-7-1

RPU2995, RPU3000, RPU3005, RPU3010 and RPU3015

- Maximum temperature of continuous operation: +85 °C
- Halogen-free

SINGLE-POLE DISTRIBUTION BLOCKS - RPU

Code	Reference		Weight (kg)	A (mm)	B (mm)	C (mm)	Fixing hole spacing (mm)
RPU2995	RPU 80-6 S	1	0,071	66	30	46	54 - 16
RPU3000	RPU 125-8 S	1	0,161	75	40	48	62 - 28
RPU3005	RPU 160-8 S	1	0,170	75	40	48	62 - 28
RPU3010	RPU 250-11 S	1	0,332	96	47	50	84 - 33
RPU3015	RPU 400-11 S	1	0,358	96	47	50	84 - 33

TECHNICAL DATA

Code	Type	In (A)		IN/OUT	COFLEX* L (mm)	Sect. (mm²)	Sect. (mm²)	Nr	Ø (mm)	I _{cc} (kA)	I _{pk} (kA)	U _i (V)
		IEC/EN	UL									
RPU2995	1-pole 6 outputs 80 A	80	85	IN	-	6 ÷ 16	6 ÷ 16	1	6.8	3	22	1000
				OUT	-	2.5 ÷ 16	2.5 ÷ 16	2	6.8			
				OUT	-	2.5 ÷ 6	2.5 ÷ 6	4	4.5			
RPU3000	1-pole 8 outputs 125 A	125	130	IN	9	10 ÷ 35	10 ÷ 35	1	11 x 9	4.4	30	1000
				IN/OUT	-	6 ÷ 16	6 ÷ 16	1	8.7 x 6			
				OUT	-	2.5 ÷ 16	2.5 ÷ 16	8	6.8			
RPU3005	1-pole 8 outputs 160 A	160	175	IN	9-13	10 ÷ 70	10 ÷ 50	1	13.5 x 11.5	11	30	1000
				IN/OUT	-	6 ÷ 16	6 ÷ 16	1	8.7 x 6			
				OUT	-	2.5 ÷ 16	2.5 ÷ 16	8	6.8			
RPU3010	1-pole 11 outputs 250 A	250	230	IN	13-15.5	35 ÷ 120	35 ÷ 95	1	16 x 14	21	51	1000
				OUT	-	6 ÷ 35	6 ÷ 25	2	9			
				OUT	-	2.5 ÷ 16	2.5 ÷ 16	5	6.8			
				OUT	-	2.5 ÷ 10	2.5 ÷ 10	4	6.1			
RPU3015	1-pole 11 outputs 400 A	400	310	IN	15.5-20	95 ÷ 185	95 ÷ 120	1	20.5 x 16	25	66	1000
				OUT	-	6 ÷ 35	6 ÷ 25	2	9			
				OUT	-	2.5 ÷ 16	2.5 ÷ 16	5	6.8			
				OUT	-	2.5 ÷ 10	2.5 ÷ 10	4	6.1			

I_{cc} pk = Short-circuit current peak value expressed in kA

I_{cc} = Effective value of short-circuit current, duration equal to 1 second, expressed in kA as per standard EN 60947-7-1

U_i = Nominal insulation voltage

Cables legend:

Stripped wire

Cable with ferrule

PRODUCTS CONFORMING TO REGULATIONS





RPU3020

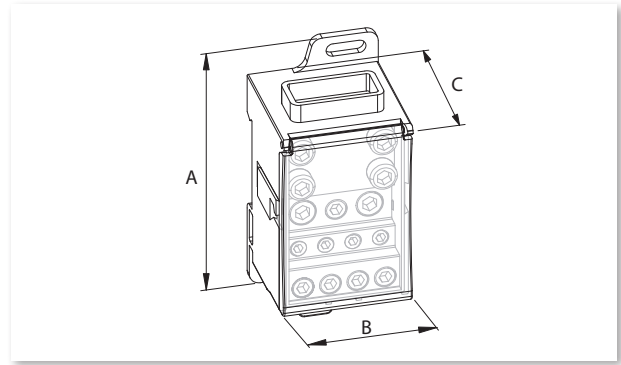

TECHNICAL CHARACTERISTICS

Insulating block: PA 6, UL 94-V0, grey RAL 7035

Protective screen: PC, UL 94-V2, transparent yellow, manually removable

Conduction block: Tinned copper.

Screws: tin-plated steel and aluminium

RPU3020

- Maximum continuous operation temperature is: +85 °C

- Halogen free

- Direct connection with COFLEX.

Protection grade IP20B

Quick hook-up on DIN rails

Compliant with standard EN 60947-7-1

RPU3020

Code	Reference		Weight (kg)	A (mm)	B (mm)	C (mm)	Fixing hole spacing (mm)
RPU3020	RPU 500-11	1	0,45	96	47	50	84 - 33

TECHNICAL DATA

Code	Type	In (A)	IN/OUT	COFLEX* L (mm)	Sect. (mm ²)	Sect. (mm ²)	Nr	∅ (mm)	I _{cw} (kA)	I _{pk} (kA)	U _i (V)
RPU3020	1-pole 11 outputs 500 A	500	IN	15.5÷24	2,5 - 95	2,5 - 70	1	24 x 9	25	63	1000
			OUT	-	6 ÷ 35	6 ÷ 25	2	9			
			OUT	-	2.5 ÷ 16	2.5 ÷ 16	5	6.8			
			OUT	-	2.5 ÷ 10	2.5 ÷ 10	4	6.1			

I_{cc pk} = Short-circuit current peak value expressed in kA

I_{cw} = Effective value of short-circuit current, duration equal to 1 second, expressed in kA as per standard EN 60947-7-1

U_i = Nominal insulation voltage

Cables legend:

Stripped wire

Cable with ferrule



TECHNICAL CHARACTERISTICS

Insulating block: PA 6, UL 94-V0, grey RAL 7035

Protective screen: PC, UL 94-V2, transparent yellow, manually removable

Conduction block: brass

Screws: tin-plated steel and aluminium

Protection grade IP20B

Quick hook-up on DIN rails

Compliant with standard EN 60947-7-1

RPT3000 and RPT3005

- Maximum continuous operation temperature is: +85 °C
- Halogen-free
- Direct connection with COFLEX

3-POLE DISTRIBUTION BLOCKS

Code	Reference		Weight (kg)	A (mm)	B (mm)	C (mm)	Hole spacing fixing (mm)
RPT3000	RPT 125-6 S	1	0,319	75	85	48	63 and 38
RPT3005	RPT 160-6 S	1	0,336	75	85	48	63 and 38

TECHNICAL DATA.

Code	Type	In (A)		IN/OUT	COFLEX* L (mm)	Sect. (mm ²)	Sect. (mm ²)	Nr	∅ (mm)	I _{cc} (kA)	I _{pk} (kA)	U _i (V)
		IEC/EN	UL									
RPT3000	3 POLE 6 outputs 125 A	125	130	IN	9	10 ÷ 35	10 ÷ 35	1	11 x 9	4.4	30	1000
				OUT	-	2.5 ÷ 16	2.5 ÷ 16	6	6.8			
RPT3005	3 POLE 6 outputs 160 A	160	175	IN	9-13	10 ÷ 70	10 ÷ 50	1	13.5 x 11.5	11	30	1000
				OUT	-	2.5 ÷ 16	2.5 ÷ 16	6	6.8			

I_{cc pk} = Short-circuit current peak value expressed in kA

I_{cc} = Effective value of short-circuit current, duration equal to 1 second, expressed in kA as per standard EN 60947-7-1

U_i = Nominal insulation voltage

Cables legend:

Stripped wire

Cable with ferrule

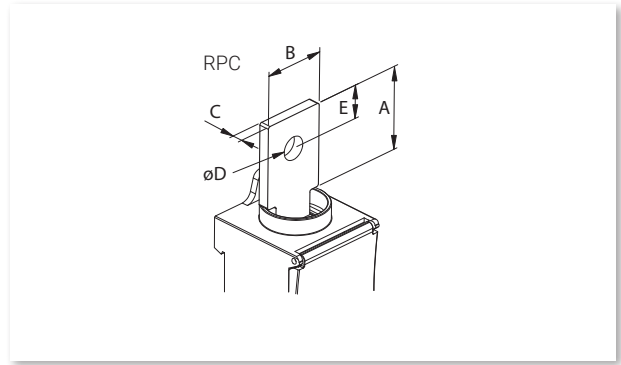

TECHNICAL CHARACTERISTICS

Material: Tinned copper

It allows connections between PTBs or Distribution Blocks and Co-Flex or J-links.

To connect J-links to PTBs or Distribution Blocks the use of RPC adapters is necessary.

Allows direct connection between PTBs or Distribution Blocks and switches.

TERMINAL FOR RPU - RPT - PTB INPUT

Code	Reference		In (A)	Weight (kg)	A (mm)	B (mm)	C (mm)	D (mm)	E (mm)
RPC3000	RPC 125A	10	125	32	25	20	4	8.5	7.5
RPC3005	RPC 160A	10	160	42	30	20	4.5	8.5	9
RPC3010	RPC 250A	10	250	64	35	25	4.5	11	12
RPC3015	RPC 400A	10	400	98	40	30	5	11	16
RPC3020	RPC 500A	10	500	125	40	32	6	13	16

COMPATIBILITY TABLE

Code	Reference	Compatible power Distribution Blocks/terminals		
RPC3000	RPC 125A	RPU3005	RPT3000	PTB6015
RPC3005	RPC 160A	RPU3005	RPT3005	PTB6020
RPC3010	RPC 250A	RPU3010		PTB6025
RPC3015	RPC 400A	RPU3015		PTB6030
RPC3020	RPC 500A	RPU3020		



TECHNICAL CHARACTERISTICS

Insulating block: PA 6, UL 94-V0, grey RAL 7035

Conduction block: brass

Screws: steel

Terminals: spring steel Protection class IP20B

Quick coupling on DIN rails or plate

by means of 4 M4 screws

Compliant with standard EN 60947-7-1

RPU5000, RPU5005 and RPU5010

- Maximum temperature of

continuous operation: +125 °C

- Halogen-free

ADVANTAGES

Extremely easy wiring

Output with spring tightening

Side-by-side elements with

interlocking connection

Highly reliable and stable

connection with:

- Rigid stripped cable

- Cable with ferrule

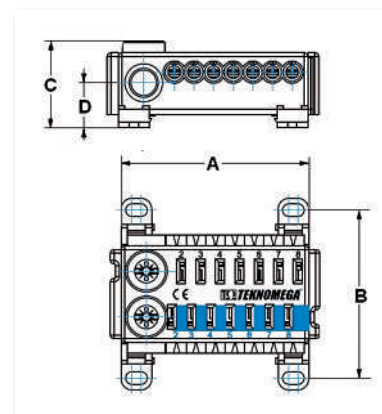

QUICK DISTRIBUTION BLOCKS (UNI AND BI-POLAR)

1 POLE

Code	Reference		Weight (kg)	A (mm)	B (mm)	C (mm)	D (mm)
RPU5000	RPU 80-S-14-B	10	0,048	53	47	24	12
RPU5005	RPU 80-S-14-G	10	0,048	53	47	24	12

TECHNICAL DATA

Code	Type	In (A)	IN/OUT	Sect. (mm ²)	Sect. (mm ²)	Nr	Ui (V)
RPU5000	1-pole 14 outputs blue 63 A	63	IN →	1.5 ÷ 25	1.5 ÷ 16	2	1000
			← OUT	0.5 ÷ 4	0.5 ÷ 4	14	
RPU5005	1-pole 14 outputs grey 63 A	63	IN →	1.5 ÷ 25	1.5 ÷ 16	2	1000
			← OUT	0.5 ÷ 4	0.5 ÷ 4	14	

2-POLE

Code	Reference		Weight (g)	A (mm)	B (mm)	C (mm)	D (mm)
RPU5010	RPB 80-S-7-BG	10	0,048	53	47	24	12

TECHNICAL DATA

Code	Type	In (A)	IN/OUT	Sect. (mm ²)	Sect. (mm ²)	Nr	Ui (V)
RPU5010	2-pole 7 outputs 63A	63	IN →	1.5 ÷ 25	1.5 ÷ 16	1	1000
			← OUT	0.5 ÷ 4	0.5 ÷ 4	7	

I_{cc pk} = Short-circuit current peak value expressed in kA

I_{cw} = Effective value of short-circuit current, duration equal to 1 second, expressed in kA as per standard EN 60947-7-1

U_i = Nominal insulation voltage

Cables legend:

Stripped wire

Cable with ferrule



TECHNICAL FEATURES

Self-extinguishing insulating block: PA 6, UL 94-V0

Cover: PC, UL 94-v2, transparent yellow, manually removable

Conduction block: tinned copper

Clamps: galvanized steel and Al alloy

Screws: galvanized steel

IP10 degree of protection ensures protection against accidental contact

Compliant with standard EN 60947-7-1

Maximum continuous operation temperature is: +85 °C 

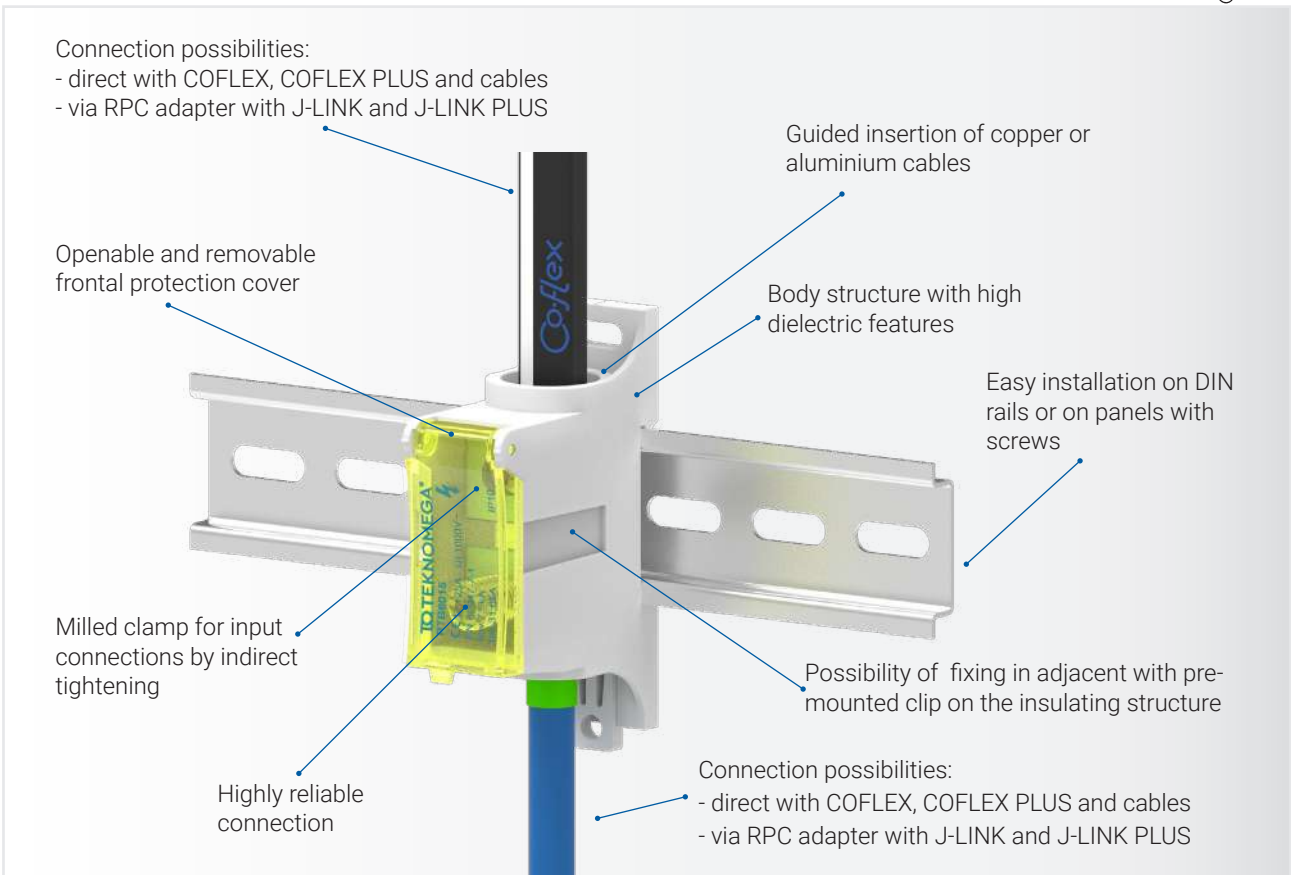

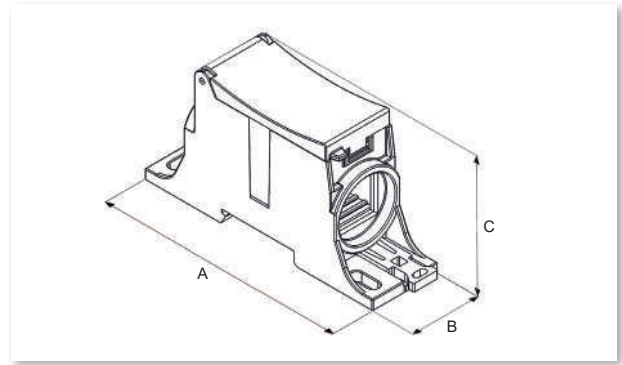



POWER TERMINALS 125-160-250-400 A

Code	Reference		Weight (kg)	A (mm)	B (mm)	C (mm)
PTB6015	PTB 125	1	0.110	84	24	54
PTB6020	PTB 160	1	0.115	84	24	54
PTB6025	PTB 250	1	0.195	111	27	56
PTB6030	PTB 400	1	0.270	111	32	60

TECHNICAL DATA

Code	Type	In (A)	IN/OUT	Recommended COFLEX* L (mm)	 Sect. (mm ²)	 Sect. (mm ²)	Nr	I _{cw} (kA)	I _{pk} (kA)	U _i (V)
PTB6015	1 POLE 1 output 125A	125	IN →	3x9x0.8	25÷35	10÷35	1	7.5	31.6	1000
			← OUT	3x9x0.8	25÷35	10÷35	1			
PTB6020	1 POLE 1 output 160A	160	IN →	3x13x0.5	25÷70	10÷50	1	11.2	41	1000
			← OUT	3x13x0.5	25÷70	10÷50	1			
PTB6025	1 POLE 1 output 250A	250	IN →	4x15.5x0.8	50÷95	35÷95	1	15.1	43.2	1000
			← OUT	4x15.5x0.8	50÷95	35÷95	1			
PTB6030	1 POLE 1 output 400A	400	IN →	6x15.5x0.8	25÷185	25÷150	1	29.6	52.3	1000
			← OUT	6x15.5x0.8	25÷185	25÷150	1			

*See the flexible bar tables COFLEX and COFLEX PLUS

I_{cc pk} = Short-circuit current peak value expressed in kA

I_{cw} = Effective value of short-circuit current, duration equal to 1 second, expressed in kA as per standard EN 60947-7-1

U_i = Nominal insulation voltage

Cables legend:

 Stripped wire

 Cable with ferrule

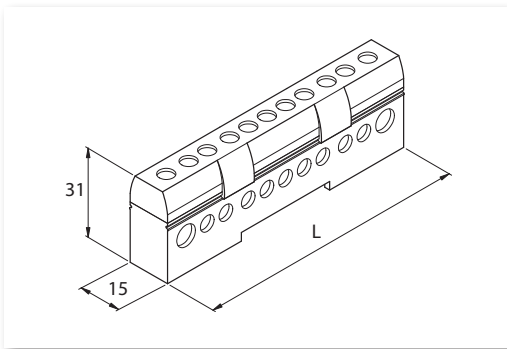
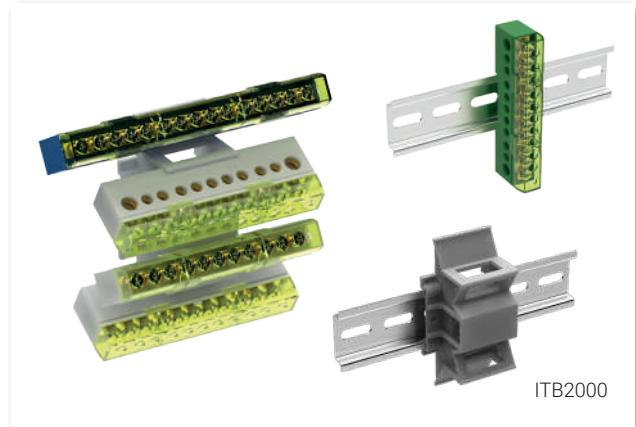
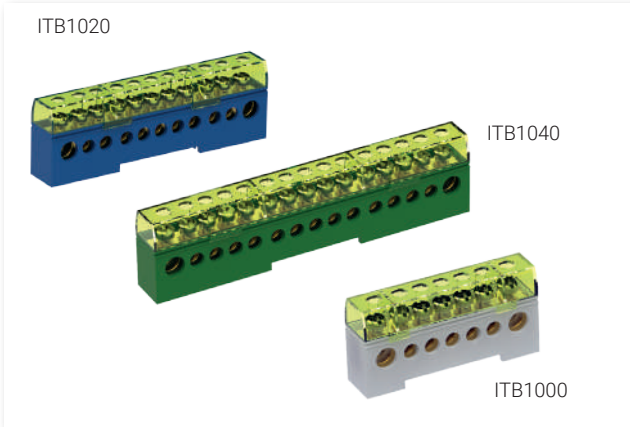

TECHNICAL CHARACTERISTICS

Insulating block: PA 6, UL 94-V0, Grey RAL 7035 - Blue RAL 5012 - Green RAL 6024

Cover: PC UL 94-V0, transparent yellow

Conduction block: Brass

Screws: Galvanized steel

Direct fitting on DIN rail or ITB2000 stand

Insulation voltage: 1000 V

Compliant with standard EN 60947-7-1

Halogen-free. IP20B degree.

Maximum continuous operation temperature is: +105 °C

1-POLE DISTRIBUTION BLOCK 80 A

Code	Reference	Color		Weight (kg)	L (mm)	∅ holes (mm)	No. holes	Sect. (mm ²)	Sect. (mm ²)
ITB1000	ITB 80-7 W	Grey	10	0.046	63	7.5	2	4 ÷ 16	2.5 ÷ 16
ITB1015	ITB 80-7 B	Blue				5.5	5	2.5 ÷ 6	1.5 ÷ 6
ITB1030	ITB 80-7 G	Green				7.5	2	4 ÷ 16	2.5 ÷ 16
ITB1005	ITB 80-11 W	Grey	10	0.070	95	7.5	2	4 ÷ 16	2.5 ÷ 16
ITB1020	ITB 80-11 B	Blue				5.5	9	2.5 ÷ 6	1.5 ÷ 6
ITB1035	ITB 80-11 G	Green	10	0.094	125	7.5	2	4 ÷ 16	2.5 ÷ 16
ITB1010	ITB 80-15 W	Grey				7.5	2	4 ÷ 16	2.5 ÷ 16
ITB1025	ITB 80-15 B	Blue				5.5	13	2.5 ÷ 6	1.5 ÷ 6
ITB1040	ITB 80-15 G	Green							

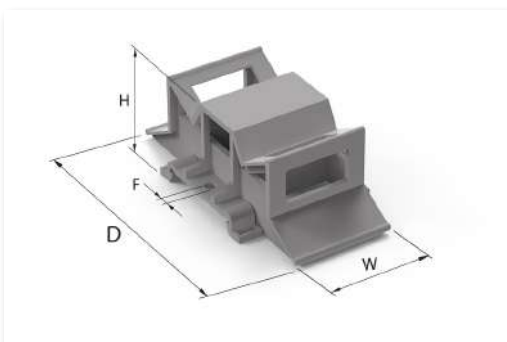

TECHNICAL CHARACTERISTICS

Material: PA 6.6, UL 94-V0, grey RAL 7035

Direct mounting on DIN rail

Mounting on steel plate by screws M4

Halogen free

Maximum continuous operation temperature is: +105 °C

ADVANTAGES

Up to 4 ITB terminal blocks can be mounted on the support it is possible to create distribution blocks of 2P, 3P or 4P

1 POLE TERMINAL BLOCK SUPPORT 80 A

Code	Reference		W (mm)	H (mm)	D (mm)	F (mm)	Hole spacing fixing (mm)
ITB2000	ITB-S DIN35	10	35	31	90	4	40

Cables legend:

- Stripped wire
- Cable with ferrule

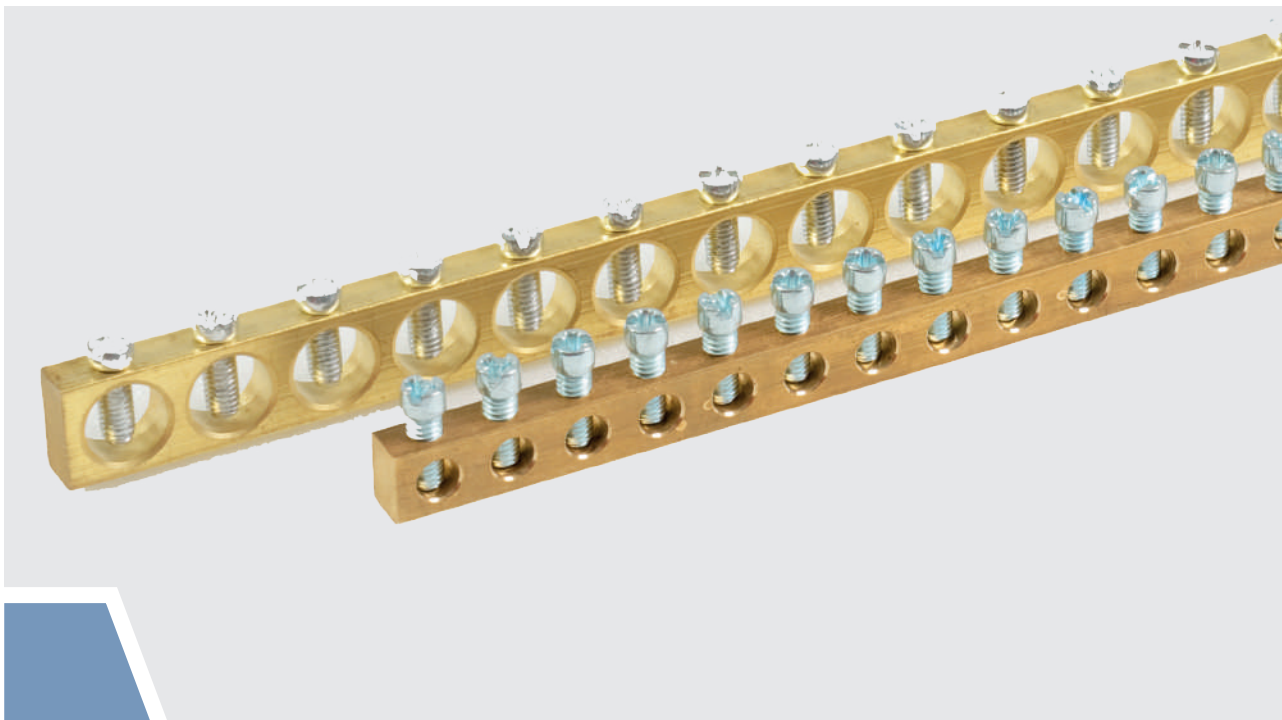

Terminal **blocks** are typically used inside switchboards or electrical cabinets for **earthing**, where small cable cross-sections are required; terminal blocks are a compact and economical solution compared to, for example, copper bars.

Due to their construction, they allow **a very high density of cable connections**, which is especially useful when there are many terminals to be connected, or in the case of cables coming from two different sides. Some models are provided with connections for cable lugs up to 95 mm².

They can be installed either vertically or horizontally, and are easy to shorten according to the space available inside the electrical equipment. Some products, e.g. MRS5000, are already designed with dimensions suitable for installation in the control cabinets of the major manufacturers on the market.

It is also possible to fix the terminal blocks directly onto a copper bar at a terminal, allowing the rest of the copper bar to be used for larger cable cross-sections.

Generally, the terminal blocks are fixed to the enclosure structure by means of the DZM metal spacers, but if there is a need to isolate them from the enclosure wall, the MRS 7000 series supports, or the CPH series or ISO series insulators can be used.

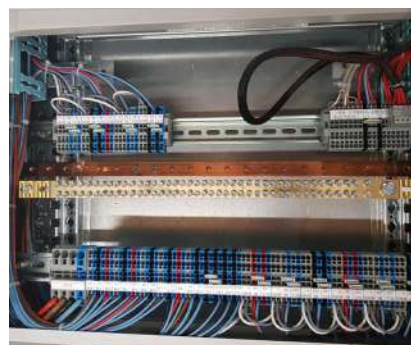
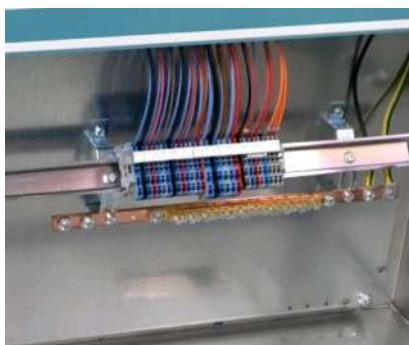

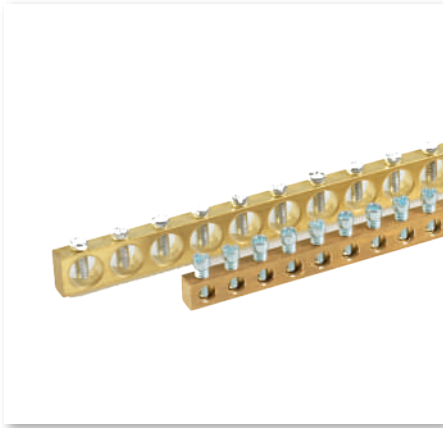

TECHNICAL CHARACTERISTICS

Material: brass

Complete with galvanized steel screws in galvanized steel

1 meter long

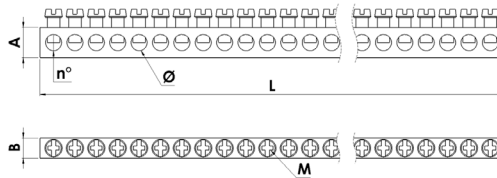

EARTHING BARS

Code	Reference		Weight (kg)	L (mm)	A (mm)	B (mm)	(m)	∅ holes (mm)	No. holes		Sect. (mm ²)		(Nm)
MRS1501	MRS 9x6	10	0.380	1000	9	6	M4	5.2	113		2.5 ÷ 6		1.2
MRS1506	MRS 12x8	10	0.774	1000	12	8	M5	6.5	116		2.5 ÷ 16		3

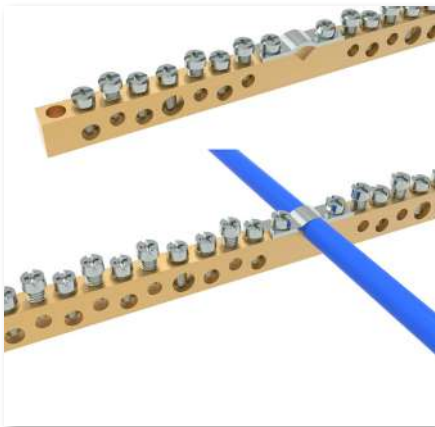

TECHNICAL CHARACTERISTICS

Material: brass

Connection with cable collar up to 25 mm²

Ends with through-hole

to facilitate fixing.

Complete with galvanized steel

M5 screws in galvanized steel.

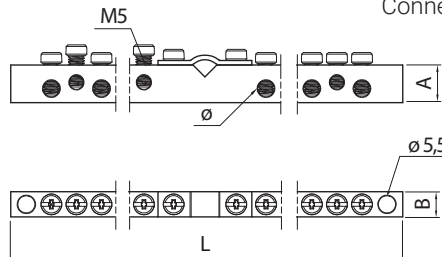

EARTHING TERMINALS WITH CABLE COLLAR

Code	Reference		Weight (kg)	L (mm)	AxB (mm)	No. inputs	∅ holes (mm)	No. holes		Sect. (mm ²)		Sect. (mm ²)		(Nm)
MRS4000	MRS 12X8-14	10	0.125	165	12x8	1	7.0	2		4 ÷ 16		2.5 ÷ 16		1.5
							5.3	6		2.5 ÷ 6		1.5 ÷ 6		1.5
							4.5	6		1.5 ÷ 4		0.75 ÷ 4		1.5
MRS4005	MRS 12X8-28	10	0.240	312	12x8	2	7.0	4		4 ÷ 16		2.5 ÷ 16		1.5
							5.3	12		2.5 ÷ 6		1.5 ÷ 6		1.5
							4.5	12		1.5 ÷ 4		0.75 ÷ 4		1.5
MRS4010	MRS 12X8-42	5	0.358	462	12x8	3	7.0	6		4 ÷ 16		2.5 ÷ 16		1.5
							5.3	18		2.5 ÷ 6		1.5 ÷ 6		1.5
							4.5	18		1.5 ÷ 4		0.75 ÷ 4		1.5

Cables legend:

Stripped wire

Cable with ferrule

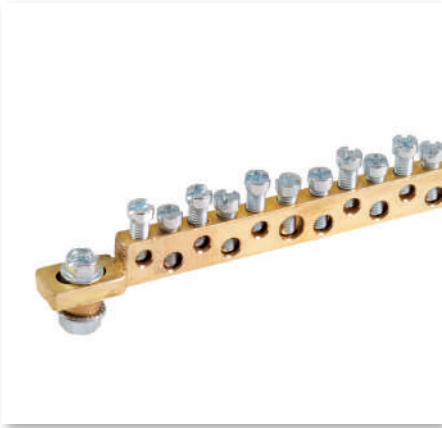

TECHNICAL CHARACTERISTICS

Material: brass

Universal fixing:

direct Fixing,
fixing on copper bar,
fixing on spacers and
extension 2 connectors.
Complete with fixings M6
and connection screws M5
in galvanized steel.

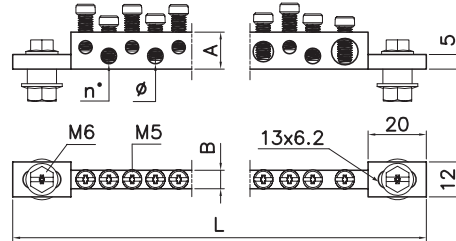

EARTHING TERMINALS

Code	Reference		Weight (kg)	L (mm)	A (mm)	B (mm)	φ holes (mm)	n° holes	Stripped wire (mm ²)	Wire with ferrule (mm ²)	(Nm)
MRS2000	MRS 13-6-20	1	0.165	215	13	6	9.1	1	16 ÷ 35	10 ÷ 35	2
							7.0	3	4 ÷ 16	2.5 ÷ 16	2
							5.3	8	2.5 ÷ 6	1.5 ÷ 6	1.5
							4.5	8	1.5 ÷ 4	0.75 ÷ 4	1.5
MRS5000	MRS 13-6-50	1	0.353	462	13	6	9.1	1	16 ÷ 35	10 ÷ 35	2
							7.0	6	4 ÷ 16	2.5 ÷ 16	2
							5.3	24	2.5 ÷ 6	1.5 ÷ 6	1.5
							4.5	19	1.5 ÷ 4	0.75 ÷ 4	1.5

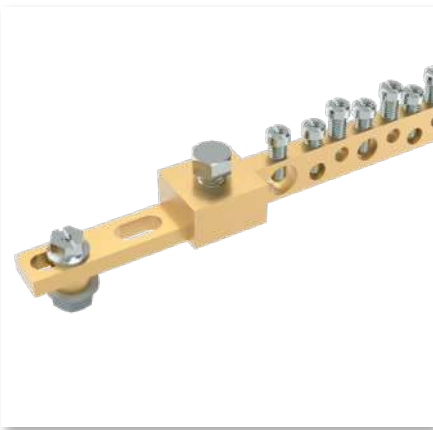

TECHNICAL CHARACTERISTICS

Material: brass

Connection with cable lug up to 95mm²

Universal fixing with 2 eyelet holes:

direct fixing on structure,
fixing on copper bars,
fixing on spacers and joining of
2 connectors.

Complete with M6 fixing screws,
M8 screws for eyelet terminals and
M5 galvanized steel connection screws.

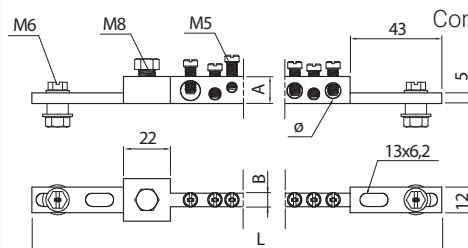

EARTHING TERMINALS WITH CONNECTIONS FOR HOUSING

Code	Reference		Weight (kg)	L (mm)	A (mm)	B (mm)	φ holes (mm)	n° holes	Stripped wire (mm ²)	Wire with ferrule (mm ²)	(Nm)
MRS5002	MRS 13-6-41	1	0.350	462	13	6	9.1	1	16 ÷ 35	10 ÷ 35	2
							7.0	7	4 ÷ 16	2.5 ÷ 16	2
							5.3	19	2.5 ÷ 6	1.5 ÷ 6	1.5
							4.5	14	1.5 ÷ 4	0.75 ÷ 4	1.5
MRS5005	MRS 13-6-56	1	0.330	462	13	6	9.1	1	16 ÷ 35	10 ÷ 35	2
							7.0	1	4 ÷ 16	2.5 ÷ 16	2
							4.5	54	1.5 ÷ 4	0.75 ÷ 4	1.5

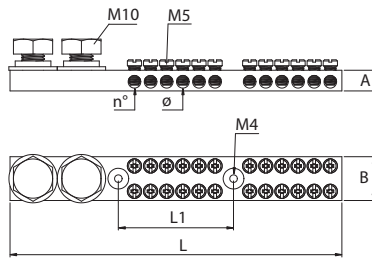
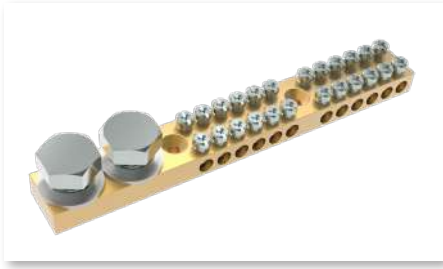

TECHNICAL CHARACTERISTICS

Material: brass
 Double connection per hole
 Double inlet up to 50 mm²
 Complete with M4 fixing screws, M10 screws for eyelet terminals and M5 galvanized steel connection screws.
 All outlets are numbered

DOUBLE-CONNECTION TERMINAL BLOCKS

Code	Reference		Weight (kg)	L (mm)	L1 (mm)	A (mm)	B (mm)	Ø holes (mm)	No. holes	Sect. (mm ²)	Sect. (mm ²)	(Nm)
MRS3000	MRS 2x6	10	0.170	102	50	9	19	2 x 6	6	2.5 ÷ 6	1.5 ÷ 6	2
MRS3005	MRS 2x12	10	0.215	144	50	9	19	2 x 12	12	2.5 ÷ 6	1.5 ÷ 6	2
MRS3010	MRS 2x24	10	0.326	230	120	9	19	2 x 24	24	2.5 ÷ 6	1.5 ÷ 6	2

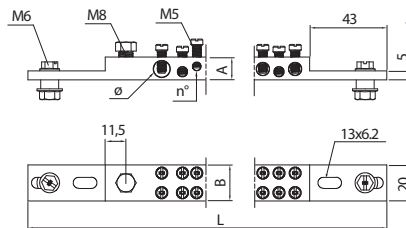

TECHNICAL CHARACTERISTICS

Material: brass
 Two rows of outlets with blind holes
 Input up to 95 mm²
Universal fixing with 2 eyelet holes:
 direct fixing on structure,
 fixing on copper bars,
 fixing on spacers and joining of 2 connectors.

Complete with M6 fixing screws, M8 screws for eyelet terminals and M5 galvanized steel connection screws.

DOUBLE EARTHING TERMINAL

Code	Reference		Weight (kg)	L (mm)	A (mm)	B (mm)	Ø holes (mm)	n° holes	Sect. (mm ²)	Sect. (mm ²)	(Nm)
MRS3500	MRS 2X41	1	0.85	462	13	20	9.1	2 x 1	16 ÷ 35	10 ÷ 35	2
							7.0	2 x 7	4 ÷ 16	2.5 ÷ 16	2
							5.3	2 x 19	2.5 ÷ 6	1.5 ÷ 6	1.5
							4.5	2 x 14	1.5 ÷ 4	0.75 ÷ 4	1.5

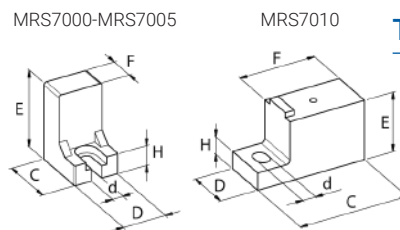
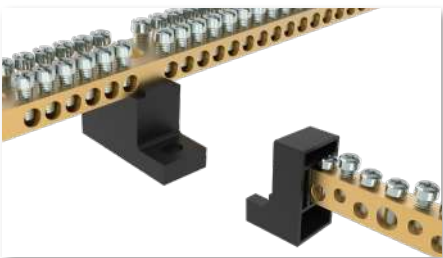

TECHNICAL CHARACTERISTICS

Material: polyamide PA 6
Color: black
Self-extinguishing: UL 94-V0
 MRS7010: complete with screw terminal block fixing screw

TERMINAL SUPPORTS

Code	Reference		Sect. brass terminal blocks A x B	C (mm)	D (mm)	E (mm)	F (mm)	H (mm)	d (mm)	Compatibility with terminal blocks
MRS7000	MRS-S 9x6	50	9 x 6	22	17.5	31	11	8	4.2	MRS1501
MRS7005	MRS-S 12x8	50	12 x 8	22	17.5	31	11	8	4.2	MRS1506
MRS7010	MRS-S 9x19	50	9 x 19	44	19	24	30	7	5.2	MRS3000 - MRS3005 - MRS3010

Cables legend:
 Stripped wire
 Cable with ferrule



THE RANGE - APPLICATIONS AND ADVANTAGES

Braided polyester sleeve GPG, GPN, GPV

- made of braided polyester monofilament to form a tubular structure
- for all electric cable wiring applications
- high expandibility value = limited number of references
- excellent resistance to abrasion and to chemical agents
- excellent mechanical protection of conductors
- halogen-free
- GPG and GPN are made of self-extinguishing material UL 94-V2, GPV are made of self-extinguishing material UL 94-V0
- GPG, GPN and GPV conduits can be cut with UTG tools (see page 93)

WRAPFLEX Openable braided sleeve GWF

- made of braided polyester monofilament + multifilament
- openable sleeve with "memory effect" for immediate closing back
- allows covering already wired cable bundles
- excellent resistance to abrasion and to chemical agents
- GWF sleeve is made of self-extinguishing material UL 94-V0
- GWF sleeves can be cut with the UTG tools (see page 93)

Fibreglass sheathing coated with silicone rubber: GSL

- made of fiberglass coated with rubber silicone
- for all electric cable wiring applications providing excellent electrical insulation and resistance to high operating temperatures
- good UV resistance
- good expandibility
- impermeable to water
- halogen-free
- good flexibility

Sleeve made of impregnated fiberglass: GFV

- made from woven glass fibre filament to form a tubular structure subsequently impregnated in a water-based varnish
- high resistance to and protection against hot temperature
- good mechanical resistance to abrasion and to chemical agents
- non-flammable
- resistant to thermal shock
- high flexibility

Spiral sleeve: GSP

- made of polyethylene
- allows covering already wired cable bundles

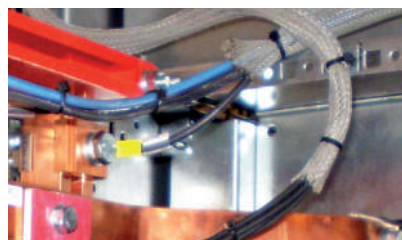
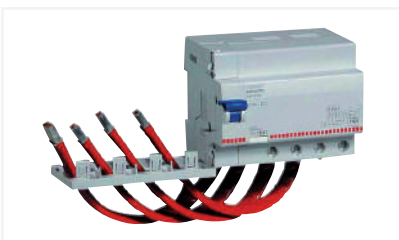



TECHNICAL CHARACTERISTICS

Material: polyester, halogen-free

Color: Grey or Black

Self-extinguishing: UL 94-V2

Working temperature: -40 °C ÷ +150 °C

Packaging: coil in cardboard box self-reeling from the center

Cutting tool: UTG tools or scissors

POLYESTER BRAIDED SLEEVE UL 94-V2 - Grey color

Code	Reference		Flat width (mm)	ø min (mm)	ø max (mm)
GPG2001	GPG 04G	100 m	4	1	8
GPG2000	GPG 06G	100 m	6	3	10
GPG2005	GPG 08G	100 m	8	5	17
GPG2010	GPG 10G	100 m	10	7	19
GPG2015	GPG 12G	50 m	14	9	24
GPG2020	GPG 15G	50 m	16	10	27
GPG2025	GPG 20G	50 m	19	14	31
GPG2029	GPG 25G	50 m	25	18	36
GPG2030	GPG 30G	50 m	32	20	56
GPG2034	GPG 35G	50 m	35	30	60
GPG2035	GPG 40G	50 m	38	35	75
GPG2040	GPG 50G	50 m	50	40	80
GPG2045	GPG 64G	25 m	64	45	105

POLYESTER BRAIDED SLEEVE UL 94-V2 - Black color

Code	Reference		Flat width (mm)	ø min (mm)	ø max (mm)
GPN2001	GPN 04N	100 m	4	1	8
GPN2000	GPN 06N	100 m	6	3	10
GPN2005	GPN 08N	100 m	8	5	17
GPN2010	GPN 10N	100 m	10	7	19
GPN2015	GPN 12N	50 m	14	9	24
GPN2020	GPN 15N	50 m	16	10	27
GPN2025	GPN 20N	50 m	19	14	31
GPN2029	GPN 25N	50 m	25	18	36
GPN2030	GPN 30N	50 m	32	20	56
GPN2034	GPN 35N	50 m	35	30	60
GPN2035	GPN 40N	50 m	38	35	75
GPN2040	GPN 50N	50 m	50	40	80
GPN2045	GPN 64N	25 m	64	45	105



TECHNICAL CHARACTERISTICS

Material: polyester, halogen-free

Color: black with grey identification wire

Self-extinguishing: UL 94-V0

Working temperature: $-40^{\circ}\text{C} \div +150^{\circ}\text{C}$

Packaging: coil in cardboard box self-reeling from the center

Cutting tool: UTG tools or scissors

POLYESTER BRAIDED SLEEVE UL 94-V0

Code	Reference		Flat width (mm)	Ø min (mm)	Ø max (mm)
GPV1000	GPV 06N	100 m	6	3	10
GPV1005	GPV 08N	100 m	8	5	17
GPV1010	GPV 10N	100 m	10	7	19
GPV1015	GPV 12N	50 m	14	9	24
GPV1020	GPV 15N	50 m	16	10	27
GPV1025	GPV 20N	50 m	19	14	31
GPV1030	GPV 30N	50 m	32	20	56
GPV1035	GPV 40N	50 m	38	35	75
GPV1040	GPV 50N	50 m	50	40	80
GPV1045	GPV 64N	25 m	64	45	105

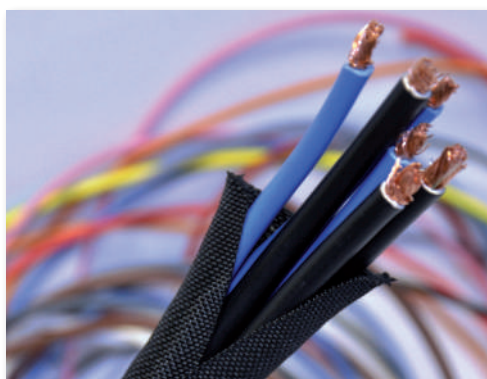

TECHNICAL CHARACTERISTICS

Material: halogen-free polyester monofilament + multifilament

Color: black

Self-extinguishing: UL 94-V0

Working temperature: $-40^{\circ}\text{C} \div +125^{\circ}\text{C}$

Self-locking sleeve

Packaging: coil in cardboard box

Cutting tool: UTG tools or scissors

WRAPFLEX SELF-CLOSING POLYESTER SLEEVE UL 94-V0

Code	Reference		Flat width (mm)	Ø max (mm)
GWF0995	GWF 05	25 m	28	5
GWF1000	GWF 08	25 m	38	8
GWF1005	GWF 13	25 m	60	13
GWF1010	GWF 19	25 m	100	19
GWF1015	GWF 25	25 m	120	25
GWF1020	GWF 32	15 m	155	32
GWF1025	GWF 38	15 m	180	38
GWF1030	GWF 50	15 m	230	50



TECHNICAL CHARACTERISTICS

Material: Silicone + internal fiberglass reinforcement

Red: color

Breaking voltage: 2500V

Working temperature: $-60^{\circ}\text{C} \div +250^{\circ}\text{C}$

Insulator up to 2500 V

Sleeve according to CEI EN 60684

Good expandibility and elasticity

Good UV resistance

Packaging: coil with transparent film

Cutting tool: scissors

FIBREGLASS COATED WITH SILICONE RUBBER

Code	Reference		Internal \varnothing (mm)
GSL1000	GSL 04	100 m	4
GSL1005	GSL 06	100 m	6
GSL1010	GSL 08	100 m	8
GSL1015	GSL 10	100 m	10
GSL1020	GSL 12	100 m	12
GSL1022	GSL 14	100 m	14
GSL1025	GSL 16	50 m	16
GSL1030	GSL 20	50 m	20
GSL1035	GSL 24	50 m	24
GSL1040	GSL 30	50 m	30



TECHNICAL CHARACTERISTICS

Material: Fibreglass impregnated with water-based paint

Color: black

Breaking voltage: 2500V

Working temperature: $-30^{\circ}\text{C} \div +250^{\circ}\text{C}$

Good flexibility

Resistant to most chemical agents

Insulator up to 1000 V

Packaging: coil

Cutting tool: UTG tools or scissors

FIBREGLASS BRAIDED SLEEVE

Code	Reference		Internal \varnothing (mm)
GFV1000	GFV 04	100 m	4
GFV1005	GFV 06	100 m	6
GFV1010	GFV 08	100 m	8
GFV1015	GFV 10	100 m	10
GFV1020	GFV 12	100 m	12
GFV1025	GFV 16	50 m	16
GFV1030	GFV 20	50 m	20

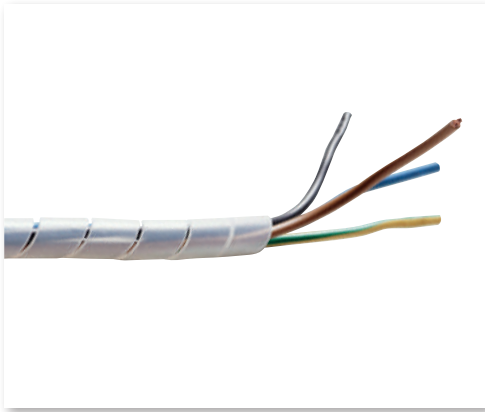

TECHNICAL CHARACTERISTICS

Material: polystyrene
Color: transparent or black (other colors upon request)

Working temperature:  -50 °C ÷ +85 °C 

Packaging: coil in plastic bag
Cutting tool: scissors

SPIRAL SLEEVE - Transparent color

Code	Reference		Internal ø nom. (mm)	ø min (mm)	ø max (mm)
GSP0995	GSP 04	25 m	3.7	4	8
GSP1000	GSP 06	25 m	4.7	5	12
GSP1002	GSP 09	25 m	7	8	16
GSP1005	GSP 12	25 m	9	10	20
GSP1007	GSP 15	25 m	11	12	24
GSP1010	GSP 20	20 m	13.6	14	30

SPIRAL SLEEVE - Black color

Code	Reference		Internal ø nom. (mm)	ø min (mm)	ø max (mm)
GSP1015	GSP 04N	25 m	3.7	4	8
GSP1020	GSP 06N	25 m	4.7	5	12
GSP1025	GSP 09N	25 m	7	8	16
GSP1030	GSP 12N	25 m	9	10	20
GSP1035	GSP 15N	25 m	11	12	24
GSP1040	GSP 20N	20 m	13.6	14	30



TECHNICAL CHARACTERISTICS

Two models to cut braided sleeves
 both manual and benchtop
 Standard wire cutting and welding
 Quick and clean operation
 UTG compatible with GPG, GPN, GPV and GWF sleeves

BRAIDED SLEEVE CUTTING TOOL

Code	Reference		Weight (kg)
UTG1000	UTG T	1	1.70
UTG1001	UTG M	1	0.94
UTG1500	UTG T-L	1	blade rec.
UTG1501	UTG M-L	1	blade rec.

UTG1000 hot blade sleeve cutting bench tool

Blade working temperature: +500 °C 

Power supply: 230 Volt / 50 Hz

Supply cable: 2 meters

Spare blade UTG1500. Only compatible with the new model UTG1000 KD-9-60.

UTG1001 hot blade sleeve cutting hand tool

Blade working temperature: +500 °C 

Power supply: 230 Volt / 50 Hz

Supply cable: 2.5 meters

Spare blade UTG1501

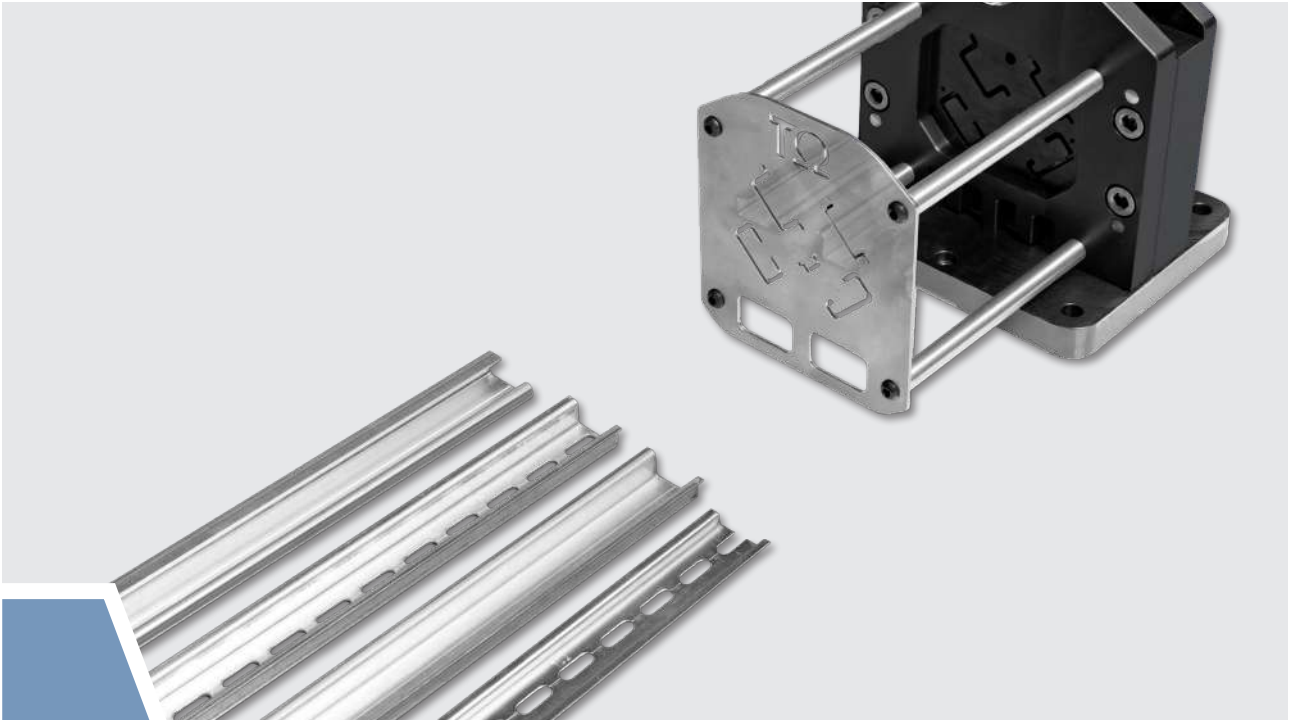

DIN RAILS

Steel and/or aluminium DIN rails standardized as per European norms which allows fitting modular electrical devices and others inside electrical panel boards.

Two general DIN rail types:

SYMMETRICAL, also said "Ω", available in three sizes.

ASYMMETRICAL, also said "G".

Steel 30 x 15 "C" profile used to make infrastructures inside the electrical panel board and/or as support for equipment or wiring elements.

Profile Symmetrical aluminium non-drilled 35 x 15.

TECHNICAL CHARACTERISTICS

Passivated galvanized steel

Senzimir galvanized steel

Aluminium

High mechanical resistance

EN 60715 - DIN 46277 Compliant with standards

Available in solid and punched versions

Standard length: 2 meters

Tools

Cutting and punching tools for DIN rail, extremely easy to use. Neat cut without burrs and material waste; supporting rail for accurate cut at 90°, ruler supplied for repeated cuts up to 1000 mm.

Supports and accessories

Wide range of clips and fasteners making it possible to conveniently fasten equipment with no provision for direct fitting on DIN rail and to fasten or space the same rail inside the panel board.

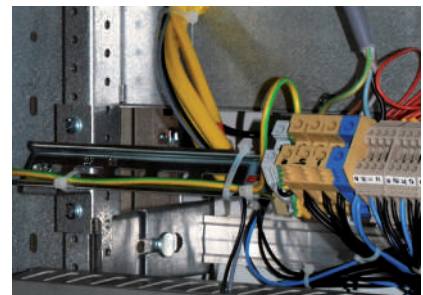
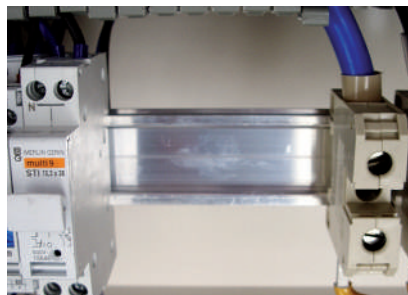
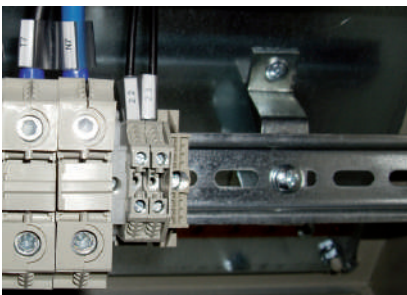

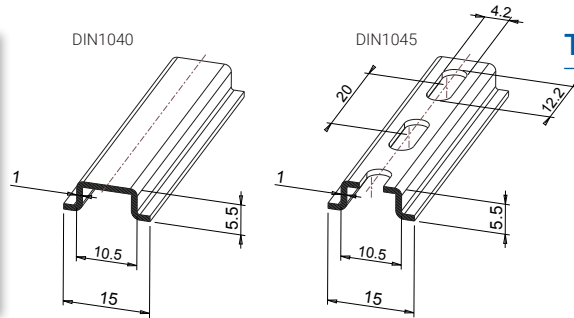

TECHNICAL CHARACTERISTICS

Material: ■ = passivated galvanised DC01 steel, minimum thickness 6µm
 EN 60715 - DIN 46277 Compliant with standards
 Available in solid and punched versions

Q-SYMMETRICAL DIN GUIDES, SIZE 15mm x 5.5mm

Code	Reference	Material	Holes	Length (m)		Weight (kg)
DIN1040	DIN NF15H5	■	x	2	20	0.33
DIN1045	DIN F15H5	■	✓	2	20	0.33

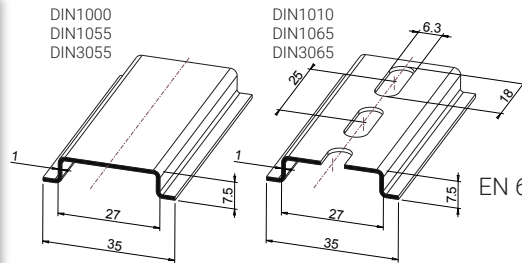

TECHNICAL CHARACTERISTICS

Material: ■ = passivated galvanised DC01 steel, minimum thickness 6µm
 ■ = galvanised steel DX51D sendzimir Z200
 EN 60715 - DIN 46277 Compliant with standards
 Available in solid and punched versions

Q-SYMMETRICAL DIN GUIDES, SIZE 35mm x 7.5mm

Code	Reference	Material	Holes	Length (m)		Weight (kg)
DIN1000	DIN NF35H7	■	x	2	20	0.70
DIN1055	DIN NF35H7Z	■	x	2	20	0.70
DIN3055	DIN NF35H7Z-3	■	x	3	10	1.05
DIN1010	DIN F35H7	■	✓	2	20	0.60
DIN1065	DIN F35H7Z	■	✓	2	20	0.60
DIN3065	DIN F35H7Z-3	■	✓	3	10	0.90

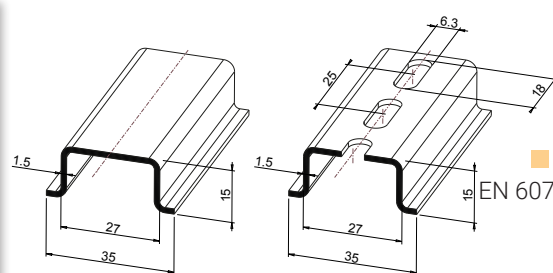

TECHNICAL CHARACTERISTICS

Material: ■ = passivated galvanised DC01 steel, minimum thickness 6µm
 ■ = galvanised steel DX51D sendzimir Z200
 EN 60715 - DIN 46277 Compliant with standards
 Available in solid and punched versions

Q-SYMMETRICAL DIN GUIDES, SIZE 35mm x 15mm

Code	Reference	Material	Holes	Length (m)		Weight (kg)
DIN1005	DIN NF35H15	■	x	2	10	1.34
DIN1060	DIN NF35H15Z	■	x	2	10	1.34
DIN3060	DIN NF35H15Z-3	■	x	3	10	2.01
DIN1015	DIN F35H15	■	✓	2	10	1.23
DIN1070	DIN F35H15Z	■	✓	2	10	1.23
DIN3070	DIN F35H15Z-3	■	✓	3	10	1.84

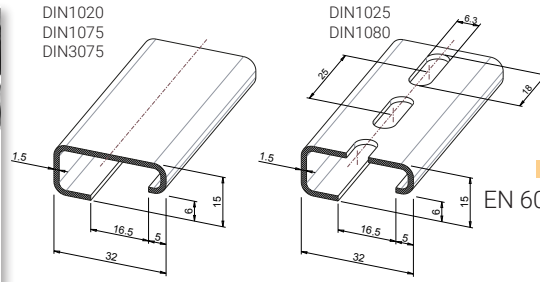

TECHNICAL CHARACTERISTICS

Material: ■ = passivated galvanised DC01 steel,

minimum thickness 6µm

■ = galvanised steel DX51D sendzimir Z200

EN 60715 - DIN 46277 Compliant with standards

Available in solid and punched versions

Ω- SYMMETRICAL "G" DIN GUIDES, SIZE 32mm x 15mm

Code	Reference	Material	Holes	Length (m)		Weight (kg)
DIN1020	DIN GNF	■	x	2	10	1.46
DIN1075	DIN ANFZ	■	x	2	10	1.46
DIN3075	DIN ANFZ-3	■	x	3	10	2.19
DIN1025	DIN GF	■	✓	2	10	1.38
DIN1080	DIN AFZ	■	✓	2	10	1.38

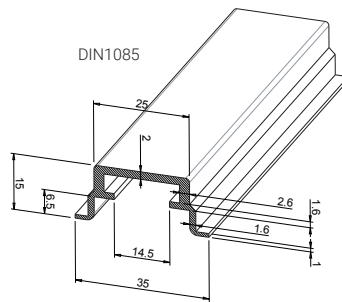

TECHNICAL CHARACTERISTICS

Material: ■ = En AW-ALMgSi- UNI EN 573/3 Al 6060 T6

EN 60715 - DIN 46277 Compliant with standards

SYMMETRICAL NON-DRILLED ALUMINIUM DIN RAIL, DIMENSIONS 35mm x 15mm

Code	Reference	Material	Length (m)		Weight (kg)
DIN1085	DIN NFAL	■	2	20	0,66

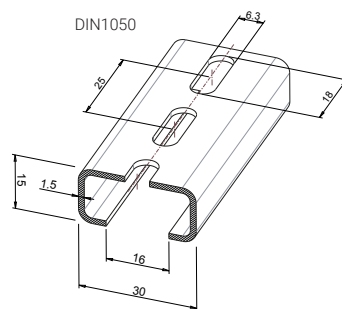

TECHNICAL CHARACTERISTICS

Material: ■ = Passivated galvanized steel minimum thickness 6µm

EN 60715 - DIN 46277 Compliant with standards

PASSIVATED GALVANISED STEEL PERFORATED C-PROFILE, SIZE 30mm x 15mm

Code	Reference	Material	Length (m)		Weight (kg)
DIN1050	CFT30H15	■	2	10	1,3

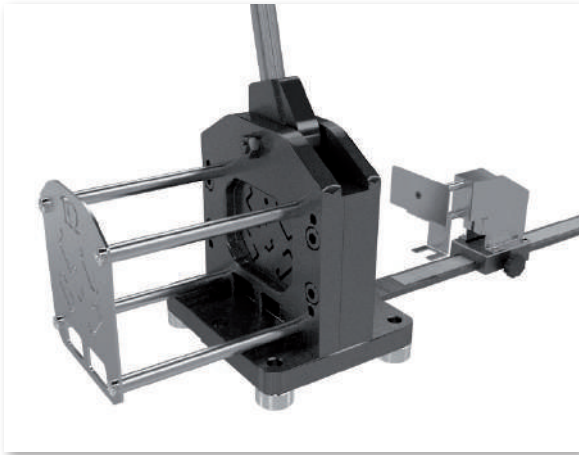

TECHNICAL CHARACTERISTICS

Cutting and punching of standardised rails and profiles.
Cutting is carried out without generating scrap or deformation of the bar and is clean and right-angled.

DIN RAIL CUTTING TOOL

Code	Reference		Weight (kg)
UTD3005	UTD-T-P 03	1	16.5

For cutting:

Symmetrical DIN rails type "Ω" 15x5,5 - 35x7,5 - 35x15
Asymmetrical DIN rail type "G" 32x15 Profile type "C" 30x15

Punching with elongated hole:

Symmetrical DIN rails type "Ω" 35x7,5 - 35x15.
Elongated hole 12x6,4 mm along or perpendicular to the length of the rail.

Supplied with rule up to 1000 mm.

Profile		Processing
Description	Ref.	
Type Ω 15 x 5.5	i	Cutting
Type Ω 35 x 7.5	ii	Cutting - punching
Type Ω 35 x 15	iii	Cutting - punching
Type G 32 x 15	iv	Cutting
Type C 30 x 15	v	Cutting

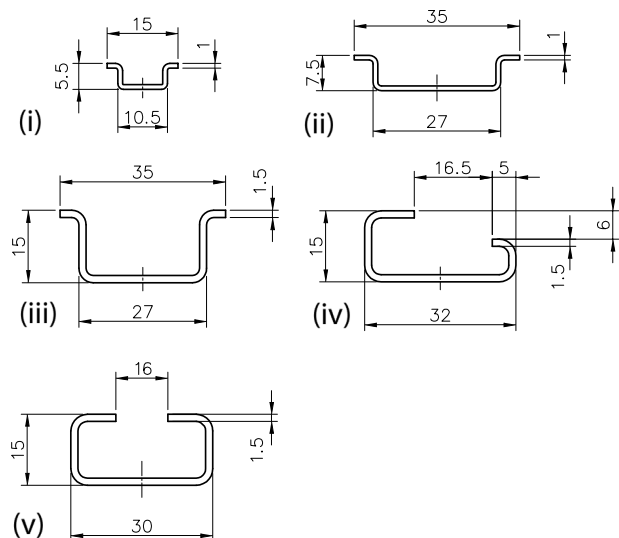

Note:

- Use with DIN rails not included in the [TEKNOMEGA](#) catalogue is not guaranteed.
- For maintenance instructions, see *Instruction and Operating Instructions*.

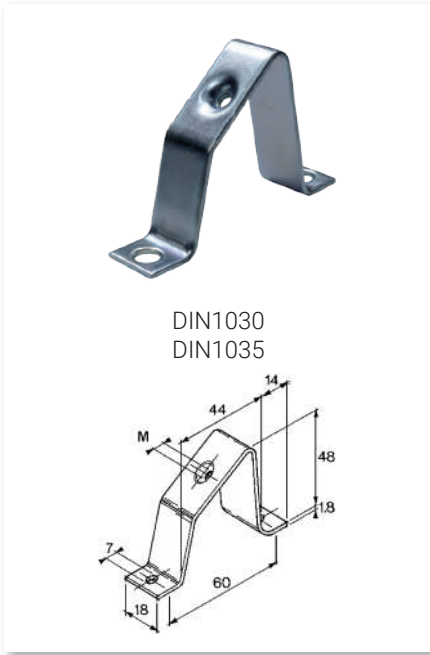

DIN1030
DIN1035

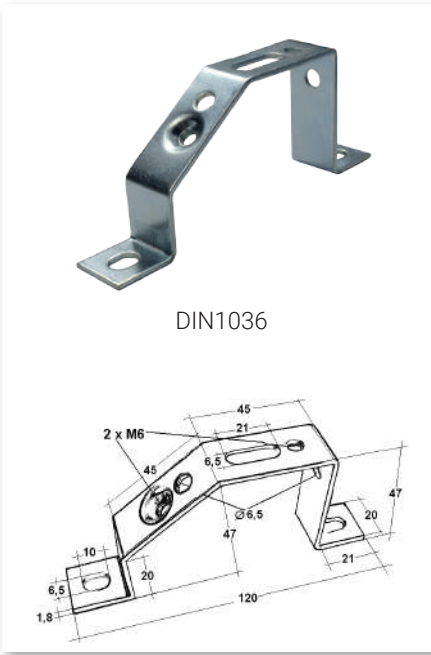

DIN1036



DIN1037

TECHNICAL CHARACTERISTICS

Material: passivated galvanized steel

45° SUPPORTS

Code	Reference		M
DIN1030	DIN ST5	10	M5
DIN1035	DIN ST6	10	M6
DIN1036	DIN ST 45PM6	10	M6
DIN1037	DIN STA 6	10	M6

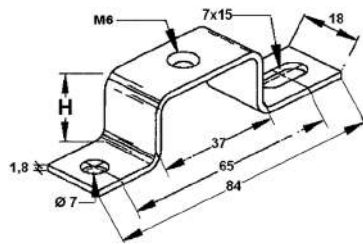

TECHNICAL CHARACTERISTICS

Material: passivated galvanized steel

FLAT SUPPORTS

Code	Reference		H (mm)
DIN1120	DIN STC 20-6	10	20
DIN1125	DIN STC 25-6	10	25
DIN1130	DIN STC 30-6	10	30
DIN1135	DIN STC 40-6	10	40
DIN1140	DIN STC 50-6	10	50
DIN1145	DIN STC 70-6	10	70
DIN1150	DIN STC 90-6	10	90

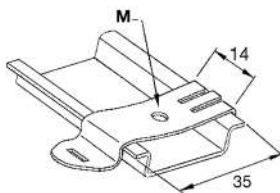

TECHNICAL CHARACTERISTICS

Material: nickel-plated steel
Clips compatible with guides
SYMMETRICAL DIN A "Q" 35x7.5 35x15

CLIP FOR SYMMETRICAL DIN RAIL

Code	Reference		M
DIN1110	DIN KLIP 4	100	M4
DIN1115	DIN KLIP 5	100	M5
DIN1117	DIN KLIP 6	100	M6

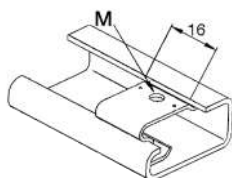

TECHNICAL CHARACTERISTICS

Material: nickel-plated steel
Clips compatible with ASYMMETRIC "G" DIN rails 32x15

CLIP FOR ASYMMETRICAL DIN RAIL

Code	Reference		M
DIN1090	DIN GKLIP 4	100	M4
DIN1095	DIN GKLIP 5	100	M5

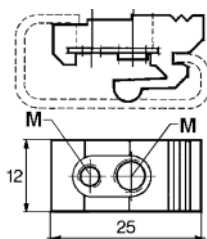

TECHNICAL CHARACTERISTICS

Material: polyamide 6.6 with insert
Passivated galvanized steel
Clips compatible with ASYMMETRIC "G" DIN rails 32x15

CLIP FOR ASYMMETRICAL DIN RAIL

Code	Reference		M
DIN1100	DIN GKLIP 3-5	100	M3 - M5
DIN1105	DIN GKLIP 4-6	100	M4 - M6

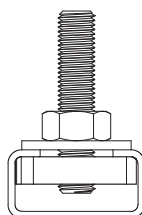
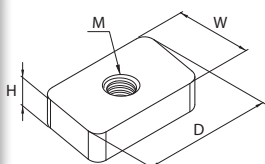



TECHNICAL CHARACTERISTICS

Material: DD11 steel EN10111
Electrogalvanized 7-8 μm

ADVANTAGES

It can be inserted into any point of the by 90° rotation
Non-slip knurled finish on the side in contact with the profile

RHOMBUS NUTS FOR C-PROFILE

Code	Reference		D (mm)	W (mm)	H (mm)	M	 (Nm)
DIN1200	DIN C30M6	10	27	16	4	M6	5
DIN1250	DIN C30M8	10	27	16	6	M8	20

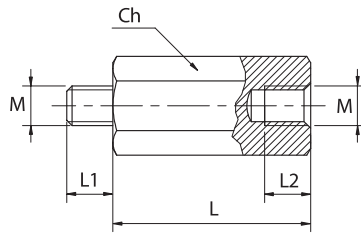
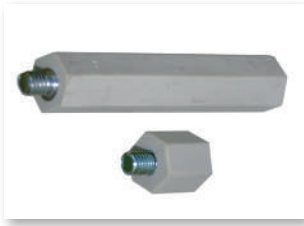

TECHNICAL CHARACTERISTICS

Material: polystyrene
Self-extinguishing: UL 94-HB
Working temperature: $-40^{\circ}\text{C} \div +110^{\circ}\text{C}$
Insulation voltage: 1000V
M-F spacers: passivated galvanised steel

PLASTIC SPACERS

Code	Reference		(m)	Ch (mm)	L (mm)	L1 (mm)	L2 (mm)
DZP1005	DZP 15M5	50	M5	13	15	7	7
DZP1010	DZP 20M5	50	M5	13	20	7	7
DZP1015	DZP 30M5	50	M5	13	30	7	7
DZP1020	DZP 45M5	50	M5	13	45	7	7
DZP1025	DZP 55M5	50	M5	13	55	7	7
DZP1030	DZP 70M5	50	M5	13	70	7	7
DZP1035	DZP 85M5	50	M5	13	85	7	7

Code	Reference		(m)	Ch (mm)	L (mm)	L1 (mm)	L2 (mm)
DZP1040	DZP 120M5	50	M5	13	120	7	7
DZP1045	DZP 15M6	50	M6	13	15	7	7
DZP1050	DZP 20M6	50	M6	13	20	7	7
DZP1055	DZP 30M6	50	M6	13	30	7	7
DZP1060	DZP 45M6	50	M6	13	45	7	7
DZP1065	DZP 70M6	50	M6	13	70	7	7
DZP1070	DZP 120M6	50	M6	13	120	7	7

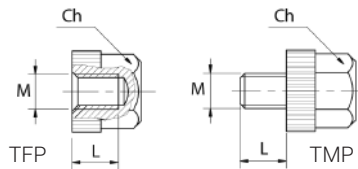

TECHNICAL CHARACTERISTICS

Material: polystyrene
Self-extinguishing: UL 94-HB
Working temperature: $-40^{\circ}\text{C} \div +110^{\circ}\text{C}$
Insulation voltage: 1000V
M-F spacers: passivated galvanised steel

PLASTIC CAPS

Code	Reference		(m)	Ch (mm)	L (mm)
TFP1000	TFP M5	50	M5	11	8
TFP1005	TFP M6	50	M6	11	8
TMP1010	TMP M5	50	M5	11	8
TMP1015	TMP M6	50	M6	11	8

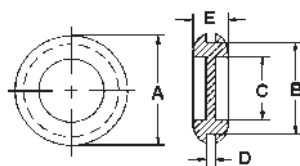

TECHNICAL CHARACTERISTICS

Material: PVC Black color
Working Temperature: $-20^{\circ}\text{C} \div +90^{\circ}\text{C}$
Flammability class: UL 94-HB

GROMMET INSERTS

Code	Reference		A (mm)	B (mm)	C (mm)	D (mm)	E (mm)
IPC1000	IPC DF13	100	17	13	8.5	2	7
IPC1005	IPC DF15,5	100	20	15.5	10.5	2	7.5
IPC1010	IPC DF19	100	24	19	14	2	8
IPC1015	IPC DF20,5	100	26	20.5	15	2	8.5
IPC1020	IPC DF23	100	29	23	18	2.5	8.5
IPC1025	IPC DF28,5	100	35	28.5	22	2.5	9
IPC1030	IPC DF37,5	100	44	37.5	32	2.5	9.5
IPC1035	IPC DF47,5	100	53	47.5	40	2.5	9.5

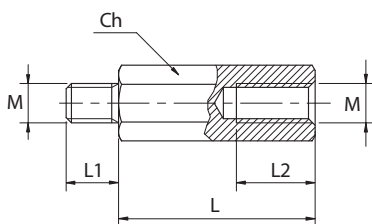

TECHNICAL CHARACTERISTICS

Material: steel with electrolytic cold galvanisation
 Hexagonal profile
 M-F (Male-Female) thread
 M3 - M4 - M5 - M6 - M8

STEEL SPACERS

Code	Reference		Ch (mm)	L (mm)	(m)	L1 (mm)	L2 (mm)
DZM0995	DZM 20M3	100	6	20	M3	6	10
DZM1000	DZM 10M4	100	7	10	M4	8	7
DZM1005	DZM 15M4	100	7	15	M4	8	10
DZM1010	DZM 20M4	100	7	20	M4	8	10
DZM1015	DZM 25M4	100	7	25	M4	8	10
DZM1020	DZM 30M4	100	7	30	M4	8	10
DZM1025	DZM 35M4	100	7	35	M4	8	10
DZM1030	DZM 40M4	100	7	40	M4	8	10
DZM1035	DZM 50M4	100	7	50	M4	8	10
DZM1040	DZM 60M4	50	7	60	M4	8	10
DZM1042	DZM 70M4	50	7	70	M4	8	10
DZM1044	DZM 90M4	50	7	90	M4	8	10
DZM1093	DZM 10M5	100	8	10	M5	8	6
DZM1045	DZM 15M5	100	8	15	M5	8	9
DZM1050	DZM 20M5	100	8	20	M5	8	10
DZM1055	DZM 25M5	100	8	25	M5	8	10
DZM1060	DZM 30M5	100	8	30	M5	8	10
DZM1065	DZM 35M5	100	8	35	M5	8	10
DZM1070	DZM 40M5	100	8	40	M5	8	10
DZM1075	DZM 50M5	50	8	50	M5	8	10
DZM1080	DZM 60M5	50	8	60	M5	8	10
DZM1085	DZM 70M5	50	8	70	M5	8	10
DZM1090	DZM 80M5	50	8	80	M5	8	10
DZM1092	DZM 90M5	50	8	90	M5	8	10
DZM1095	DZM 10M6	100	10	10	M6	10	6
DZM1100	DZM 15M6	100	10	15	M6	10	10
DZM1105	DZM 20M6	100	10	20	M6	10	12
DZM1106	DZM 25M6	100	10	25	M6	10	12
DZM1110	DZM 30M6	100	10	30	M6	10	12
DZM1115	DZM 40M6	50	10	40	M6	10	12
DZM1120	DZM 50M6	50	10	50	M6	10	12
DZM1125	DZM 60M6	50	10	60	M6	10	12
DZM1130	DZM 70M6	50	10	70	M6	10	12
DZM1135	DZM 80M6	50	10	80	M6	10	12
DZM1140	DZM 90M6	25	10	90	M6	10	12
DZM1145	DZM 100M6	25	10	100	M6	10	12
DZM1150	DZM 20M8	50	13	20	M8	14	14
DZM1155	DZM 25M8	50	13	25	M8	14	14
DZM1160	DZM 30M8	50	13	30	M8	14	14
DZM1165	DZM 40M8	25	13	40	M8	14	14
DZM1170	DZM 50M8	25	13	50	M8	14	14
DZM1175	DZM 70M8	25	13	70	M8	14	14

Code	Riferimento	Pagina
BAP		
BAP2000	BAP 20x10x2000	40
BAP2005	BAP 30x10x2000	40
BAP2010	BAP 40x10x2000	40
BAP2015	BAP 50x10x2000	40
BAP2020	BAP 60x10x2000	40
BAP2025	BAP 80x10x2000	40
BAP2030	BAP 100x10x2000	40
BAP2035	BAP 120x10x2000	40
BAP4000	BAP 20x10x4000	40
BAP4005	BAP 30x10x4000	40
BAP4010	BAP 40x10x4000	40
BAP4015	BAP 50x10x4000	40
BAP4020	BAP 60x10x4000	40
BAP4025	BAP 80x10x4000	40
BAP4030	BAP 100x10x4000	40
BAP4035	BAP 120x10x4000	40

BOC		
BOC1000	BOC RIP 8	41
BOC1005	BOC KIT 8-5	41
BOC1010	BOC KIT 8-10	41

BRF		
BRF0990	BRF 12X2X1000	37
BRF0995	BRF 12X3X1000	37
BRF1000	BRF 12X4X1000	37
BRF1005	BRF 12X5X1000	37
BRF1010	BRF 15X5X1000	37
BRF1015	BRF 20X5X1000	37
BRF1016	BRF 25X4X1000	37
BRF1017	BRF 25X5X1000	37
BRF1020	BRF 32X5X1000	37
BRF1025	BRF 12X4X2000	37
BRF1030	BRF 15X5X2000	37
BRF1031	BRF 15X5X2000 PC	37
BRF1035	BRF 20X5X2000	37
BRF1036	BRF 20X5X2000 PC	37
BRF1040	BRF 30X5X2000	37
BRF1041	BRF 32X5X2000-W	37
BRF1042	BRF 32X5X2000	37
BRF1045	BRF 30X10X1000	37
BRF1047	BRF 30X10X2000	37

BRP		
BRP1000	BRP 25X5	38
BRP1005	BRP 50X5	38
BRP1010	BRP 63X5	38
BRP1015	BRP 80X5	38
BRP1020	BRP 100X5	38
BRP1030	BRP 50X10	38
BRP1035	BRP 60X10	38
BRP1040	BRP 80X10	38
BRP1045	BRP 100X10	38
BRP1050	BRP 120X10	38

Code	Riferimento	Pagina
CFX		
CFX1005	CFX 3X9X0,8	15
CFX1020	CFX 6X9X0,8	15
CFX1021	CFX 9X9X0,8	15
CFX1022	CFX 3X13X0,5	15
CFX1023	CFX 6X13X0,5	15
CFX1024	CFX 10X13X0,5	15
CFX1025	CFX 2X15,5X0,8	15
CFX1035	CFX 4X15,5X0,8	15
CFX1045	CFX 6X15,5X0,8	15
CFX1050	CFX 10X15,5X0,8	15
CFX1055	CFX 2X20X1	15
CFX1060	CFX 3X20X1	15
CFX1065	CFX 4X20X1	15
CFX1070	CFX 5X20X1	15
CFX1075	CFX 6X20X1	15
CFX1076	CFX 8X20X1	15
CFX1080	CFX 10X20X1	15
CFX1085	CFX 2X24X1	15
CFX1090	CFX 3X24X1	15
CFX1095	CFX 4X24X1	15
CFX1100	CFX 5X24X1	15
CFX1105	CFX 6X24X1	15
CFX1110	CFX 8X24X1	15
CFX1115	CFX 10X24X1	15
CFX1120	CFX 2X32X1	15
CFX1125	CFX 3X32X1	15
CFX1130	CFX 4X32X1	15
CFX1135	CFX 5X32X1	15
CFX1140	CFX 6X32X1	15
CFX1145	CFX 8X32X1	15
CFX1150	CFX 10X32X1	15
CFX1155	CFX 2X40X1	15
CFX1160	CFX 3X40X1	15
CFX1165	CFX 4X40X1	15
CFX1170	CFX 5X40X1	15
CFX1175	CFX 6X40X1	15
CFX1180	CFX 8X40X1	15
CFX1185	CFX 10X40X1	15
CFX1190	CFX 3X50X1	15
CFX1195	CFX 4X50X1	15
CFX1200	CFX 5X50X1	15
CFX1205	CFX 6X50X1	15
CFX1210	CFX 8X50X1	15
CFX1215	CFX 10X50X1	15
CFX1220	CFX 3X63X1	15
CFX1225	CFX 4X63X1	15
CFX1230	CFX 5X63X1	15
CFX1235	CFX 6X63X1	15
CFX1240	CFX 8X63X1	15
CFX1245	CFX 10X63X1	15
CFX1250	CFX 3X80X1	15
CFX1255	CFX 4X80X1	15
CFX1260	CFX 5X80X1	15

Code	Riferimento	Pagina
CFX1265	CFX 6X80X1	15
CFX1270	CFX 8X80X1	15
CFX1275	CFX 10X80X1	15
CFX1280	CFX 4X100X1	15
CFX1285	CFX 5X100X1	15
CFX1290	CFX 6X100X1	15
CFX1295	CFX 8X100X1	15
CFX1300	CFX 10X100X1	15
CFX1305	CFX 12X100X1	15
CFX3005	CFX 3X9X0,8-3	16
CFX3055	CFX 2X20X1-3	16
CFX3060	CFX 3X20X1-3	16
CFX3065	CFX 4X20X1-3	16
CFX3070	CFX 5X20X1-3	16
CFX3085	CFX 2X24X1-3	16
CFX3090	CFX 3X24X1-3	16
CFX3095	CFX 4X24X1-3	16
CFX3100	CFX 5X24X1-3	16
CFX3120	CFX 2X32X1-3	16
CFX3125	CFX 3X32X1-3	16
CFX3135	CFX 5X32X1-3	16
CFX3145	CFX 8X32X1-3	16
CFX3170	CFX 5X40X1-3	16
CFX3185	CFX 10X40X1-3	16
CFX3200	CFX 5X50X1-3	16
CFX5005	CFP 3X9X0,8	19
CFX5020	CFP 6X9X0,8	19
CFX5021	CFP 9X9X0,8	19
CFX5022	CFP 3X13X0,5	19
CFX5023	CFP 6X13X0,5	19
CFX5024	CFP 10X13X0,5	19
CFX5025	CFP 2X15,5X0,8	19
CFX5035	CFP 4X15,5X0,8	19
CFX5045	CFP 6X15,5X0,8	19
CFX5050	CFP 10X15,5X0,8	19
CFX5055	CFP 2X20X1	19
CFX5060	CFP 3X20X1	19
CFX5065	CFP 4X20X1	19
CFX5070	CFP 5X20X1	19
CFX5075	CFP 6X20X1	19
CFX5076	CFP 8X20X1	19
CFX5080	CFP 10X20X1	19
CFX5085	CFP 2X24X1	19
CFX5090	CFP 3X24X1	19
CFX5095	CFP 4X24X1	19
CFX5100	CFP 5X24X1	19
CFX5105	CFP 6X24X1	19
CFX5110	CFP 8X24X1	19
CFX5115	CFP 10X24X1	19
CFX5120	CFP 2X32X1	19
CFX5125	CFP 3X32X1	19
CFX5130	CFP 4X32X1	19
CFX5135	CFP 5X32X1	19
CFX5140	CFP 6X32X1	19

Code	Riferimento	Pagina
CFX5145	CFP 8X32X1	19
CFX5150	CFP 10X32X1	19
CFX5155	CFP 2X40X1	19
CFX5160	CFP 3X40X1	19
CFX5165	CFP 4X40X1	19
CFX5170	CFP 5X40X1	19
CFX5175	CFP 6X40X1	19
CFX5180	CFP 8X40X1	19
CFX5185	CFP 10X40X1	19
CFX5190	CFP 3X50X1	19
CFX5195	CFP 4X50X1	19
CFX5200	CFP 5X50X1	19
CFX5205	CFP 6X50X1	19
CFX5210	CFP 8X50X1	19
CFX5215	CFP 10X50X1	19
CFX5220	CFP 3X63X1	19
CFX5225	CFP 4X63X1	19
CFX5230	CFP 5X63X1	19
CFX5235	CFP 6X63X1	19
CFX5240	CFP 8X63X1	19
CFX5245	CFP 10X63X1	19
CFX5250	CFP 3X80X1	19
CFX5255	CFP 4X80X1	19
CFX5260	CFP 5X80X1	19
CFX5265	CFP 6X80X1	19
CFX5270	CFP 8X80X1	19
CFX5275	CFP 10X80X1	19
CFX5280	CFP 4X100X1	19
CFX5285	CFP 5X100X1	19
CFX5290	CFP 6X100X1	19
CFX5295	CFP 8X100X1	19
CFX5300	CFP 10X100X1	19
CFX5305	CFP 12X100X1	19

CPH

CPH2000	CPH 16M4	58
CPH2005	CPH 20M4	58
CPH2007	CPH 20M5	58
CPH2010	CPH 20M6	58
CPH2015	CPH 25M5	58
CPH2020	CPH 25M6	58
CPH2025	CPH 30M6	58
CPH2030	CPH 30M8	58
CPH2035	CPH 35M6	58
CPH2040	CPH 35M8	58
CPH2045	CPH 35M10	58
CPH2046	CPH 35M8W	58
CPH2048	CPH 35M10W	58
CPH2050	CPH 40M6	58
CPH2055	CPH 40M8	58
CPH2060	CPH 40M10	58
CPH2065	CPH 45M6	58
CPH2070	CPH 45M8	58
CPH2075	CPH 45M10	58
CPH2080	CPH 50M6	58

Code	Riferimento	Pagina
CPH2085	CPH 50M8	58
CPH2090	CPH 50 M10	58
CPH2093	CPH 50M12W	58
CPH2095	CPH 60M8	58
CPH2100	CPH 60M10	58
CPH2101	CPH 70M10	58
CPH2102	CPH 65M10	58
CPH2103	CPH 70M12	58
CPH2104	CPH 75M10	58
CPH2105	CPH 75M12	58
CPH2112	CPH 80M12	58
CPH2115	CPH 100M12	58
CPH2117	CPH 100M16	58
CPH2510	CLH 16M5-20	59
CPH2515	CLH 16M6-20	59
CPH2520	CLH 20M5-20	59
CPH2525	CLH 20M6-20	59
CPH2530	CLH 25M5-20	59
CPH2535	CLH 25M6-20	59
CPH2540	CLH 25M8-20	59
CPH2545	CLH 30M6-20	59
CPH2550	CLH 30M8-20	59
CPH2555	CLH 35M6-20	59
CPH2560	CLH 35M8-20	59
CPH2565	CLH 40M6-20	59
CPH2570	CLH 40M8-20	59
CPH2575	CLH 45M6-20	59
CPH2580	CLH 45M8-20	59
CPH2585	CLH 50M6-20	59
CPH2590	CLH 50M8-20	59
CPH2610	CLH 30M8-30	59
CPH2615	CLH 35M8-30	59
CPH2620	CLH 40M8-30	59
CPH2625	CLH 45M8-30	59
CPH2630	CLH 50M6-30	59
CPH2635	CLH 50M8-30	59
CPH2640	CLH 55M6-30	59
CPH2645	CLH 55M8-30	59
CPH2650	CLH 65M6-30	59
CPH2655	CLH 65M8-30	59
CPH2660	CLH 70M6-30	59
CPH2665	CLH 70M8-30	59

DIN

DIN1000	DIN NF35H7	95
DIN1005	DIN NF35H15	95
DIN1010	DIN F35H7	95
DIN1015	DIN F35H15	95
DIN1020	DIN GNF	96
DIN1025	DIN GF	96
DIN1030	DIN ST5	98
DIN1035	DIN ST6	98
DIN1036	DIN ST 45PM6	98
DIN1037	DIN STA 6	98
DIN1040	DIN NF15H5	95

Code	Riferimento	Pagina
DIN1045	DIN F15H5	95
DIN1050	CFT30H15	96
DIN1055	DIN NF35H7Z	95
DIN1060	DIN NF35H15Z	95
DIN1065	DIN F35H7Z	95
DIN1070	DIN F35H15Z	95
DIN1075	DIN ANFZ	96
DIN1080	DIN AFZ	96
DIN1085	DIN NFAL	96
DIN1090	DIN GKLIP 4	99
DIN1095	DIN GKLIP 5	99
DIN1100	DIN GKLIP 3-5	99
DIN1105	DIN GKLIP 4-6	99
DIN1110	DIN KLIP 4	99
DIN1115	DIN KLIP 5	99
DIN1117	DIN KLIP 6	99
DIN1120	DIN STC 20-6	98
DIN1125	DIN STC 25-6	98
DIN1130	DIN STC 30-6	98
DIN1135	DIN STC 40-6	98
DIN1140	DIN STC 50-6	98
DIN1145	DIN STC 70-6	98
DIN1150	DIN STC 90-6	98
DIN1200	DIN C30M6	99
DIN1250	DIN C30M8	99
DIN3055	DIN NF35H7Z-3	95
DIN3060	DIN NF35H15Z-3	95
DIN3065	DIN F35H7Z-3	95
DIN3070	DIN F35H15Z-3	95
DIN3075	DIN ANFZ-3	96

DZM

DZM0995	DZM 20M3	101
DZM1000	DZM 10M4	101
DZM1005	DZM 15M4	101
DZM1010	DZM 20M4	101
DZM1015	DZM 25M4	101
DZM1020	DZM 30M4	101
DZM1025	DZM 35M4	101
DZM1030	DZM 40M4	101
DZM1035	DZM 50M4	101
DZM1040	DZM 60M4	101
DZM1042	DZM 70M4	101
DZM1044	DZM 90M4	101
DZM1045	DZM 15M5	101
DZM1050	DZM 20M5	101
DZM1055	DZM 25M5	101
DZM1060	DZM 30M5	101
DZM1065	DZM 35M5	101
DZM1070	DZM 40M5	101
DZM1075	DZM 50M5	101
DZM1080	DZM 60M5	101
DZM1085	DZM 70M5	101
DZM1090	DZM 80M5	101
DZM1092	DZM 90M5	101

Code	Riferimento	Pagina
DZM1093	DZM 10M5	101
DZM1095	DZM 10M6	101
DZM1100	DZM 15M6	101
DZM1105	DZM 20M6	101
DZM1106	DZM 25M6	101
DZM1110	DZM 30M6	101
DZM1115	DZM 40M6	101
DZM1120	DZM 50M6	101
DZM1125	DZM 60M6	101
DZM1130	DZM 70M6	101
DZM1135	DZM 80M6	101
DZM1140	DZM 90M6	101
DZM1145	DZM 100M6	101
DZM1150	DZM 20M8	101
DZM1155	DZM 25M8	101
DZM1160	DZM 30M8	101
DZM1165	DZM 40M8	101
DZM1170	DZM 50M8	101
DZM1175	DZM 70M8	101

DZP		
DZP1005	DZP 15M5	100
DZP1010	DZP 20M5	100
DZP1015	DZP 30M5	100
DZP1020	DZP 45M5	100
DZP1025	DZP 55M5	100
DZP1030	DZP 70M5	100
DZP1035	DZP 85M5	100
DZP1040	DZP 120M5	100
DZP1045	DZP 15M6	100
DZP1050	DZP 20M6	100
DZP1055	DZP 30M6	100
DZP1060	DZP 45M6	100
DZP1065	DZP 70M6	100
DZP1070	DZP 120M6	100
DZP2000	DZP KIT	65
DZP3000	DZP BFX32	22

FLT		
FLT1000	FLT PR 2000	55
FLT1015	FLT LT-T	55
FLT1020	FLT LT-TN	55
FLT1025	FLT LL-T	55
FLT1030	FLT LL-TN	55

GFV		
GFV1000	GFV 04	91
GFV1005	GFV 06	91
GFV1010	GFV 08	91
GFV1015	GFV 10	91
GFV1020	GFV 12	91
GFV1025	GFV 16	91
GFV1030	GFV 20	91

GPG		
GPG2000	GPG 06G	89

Code	Riferimento	Pagina
GPG2001	GPG 04G	89
GPG2005	GPG 08G	89
GPG2010	GPG 10G	89
GPG2015	GPG 12G	89
GPG2020	GPG 15G	89
GPG2025	GPG 20G	89
GPG2029	GPG 25G	89
GPG2030	GPG 30G	89
GPG2034	GPG 35G	89
GPG2035	GPG 40G	89
GPG2040	GPG 50G	89
GPG2045	GPG 64G	89

GPN		
GPN2000	GPN 06N	89
GPN2001	GPN 04N	89
GPN2005	GPN 08N	89
GPN2010	GPN 10N	89
GPN2015	GPN 12N	89
GPN2020	GPN 15N	89
GPN2025	GPN 20N	89
GPN2029	GPN 25N	89
GPN2030	GPN 30N	89
GPN2034	GPN 35N	89
GPN2035	GPN 40N	89
GPN2040	GPN 50N	89
GPN2045	GPN 64N	89

GPV		
GPV1000	GPV 06N	90
GPV1005	GPV 08N	90
GPV1010	GPV 10N	90
GPV1015	GPV 12N	90
GPV1020	GPV 15N	90
GPV1025	GPV 20N	90
GPV1030	GPV 30N	90
GPV1035	GPV 40N	90
GPV1040	GPV 50N	90
GPV1045	GPV 64N	90

GSL		
GSL1000	GSL 04	91
GSL1005	GSL 06	91
GSL1010	GSL 08	91
GSL1015	GSL 10	91
GSL1020	GSL 12	91
GSL1022	GSL 14	91
GSL1025	GSL 16	91
GSL1030	GSL 20	91
GSL1035	GSL 24	91
GSL1040	GSL 30	91

GSP		
GSP0995	GSP 04	92
GSP1000	GSP 06	92
GSP1002	GSP 09	92

Code	Riferimento	Pagina
GSP1005	GSP 12	92
GSP1007	GSP 15	92
GSP1010	GSP 20	92
GSP1015	GSP 04N	92
GSP1020	GSP 06N	92
GSP1025	GSP 09N	92
GSP1030	GSP 12N	92
GSP1035	GSP 15N	92
GSP1040	GSP 20N	92

GWF		
GWF0995	GWF 05	90
GWF1000	GWF 08	90
GWF1005	GWF 13	90
GWF1010	GWF 19	90
GWF1015	GWF 25	90
GWF1020	GWF 32	90
GWF1025	GWF 38	90
GWF1030	GWF 50	90

IPC		
IPC1000	IPC DF13	100
IPC1005	IPC DF15,5	100
IPC1010	IPC DF19	100
IPC1015	IPC DF20,5	100
IPC1020	IPC DF23	100
IPC1025	IPC DF28,5	100
IPC1030	IPC DF37,5	100
IPC1035	IPC DF47,5	100

ISO		
ISO2000	ISO 15M4 UL	60
ISO2005	ISO 20M4 UL	60
ISO2007	ISO 20M5 UL	60
ISO2010	ISO 20M6 UL	60
ISO2015	ISO 25M5 UL	60
ISO2020	ISO 25M6 UL	60
ISO2025	ISO 30M6 UL	60
ISO2030	ISO 30M8 UL	60
ISO2035	ISO 35M6 UL	60
ISO2040	ISO 35M8 UL	60
ISO2045	ISO 35M10 UL	60
ISO2046	ISO 35M8W UL	60
ISO2048	ISO 35M10W UL	60
ISO2050	ISO 40M6 UL	60
ISO2055	ISO 40M8 UL	60
ISO2060	ISO 40M10 UL	60
ISO2061	ISO 40M8W UL	60
ISO2063	ISO 40M10W UL	60
ISO2065	ISO 45M6 UL	60
ISO2070	ISO 45M8 UL	60
ISO2075	ISO 45M10 UL	60
ISO2076	ISO 45M8W UL	60
ISO2078	ISO 45M10W UL	60
ISO2080	ISO 50M6 UL	60
ISO2085	ISO 50M8 UL	60

Code	Riferimento	Pagina	Code	Riferimento	Pagina	Code	Riferimento	Pagina
ISO2090	ISO 50M10 UL	60	ISO3005	ISO PM6x30	62	JLK1105	JLK 240-430	26
ISO2091	ISO 50M10W UL	60	ISO3010	ISO PM8x30	62	JLK1110	JLK 240-530	26
ISO2093	ISO 50M12W UL	60	ISO3015	ISO PM8x35	62	JLK1115	JLK 240-630	26
ISO2094	ISO 55M10 UL	60	ISO3020	ISO PM10x40	62	JLK1120	JLK 240-730	26
ISO2095	ISO 60M8 UL	60	ISO3025	ISO PM12x50	62	JLK1125	JLK 240-830	26
ISO2100	ISO 60M10 UL	60	ITB			JLK1130	JLK 240-930	26
ISO2101	ISO 70M10 UL	60	ITB1000	ITB 80-7 W	83	JLK1135	JLK 240-1030	26
ISO2103	ISO 70M12 UL	60	ITB1015	ITB 80-7 B	83	JLK1140	JLK 85-230	26
ISO2105	ISO 75M12 UL	60	ITB1030	ITB 80-7 G	83	JLK1145	JLK 85-330	26
ISO2110	ISO 75M16 UL	60	ITB1005	ITB 80-11 W	83	JLK1150	JLK 85-430	26
ISO2112	ISO 80M12 UL	60	ITB1020	ITB 80-11 B	83	JLK1155	JLK 85-530	26
ISO2115	ISO 100M12 UL	60	ITB1035	ITB 80-11 G	83	JLK1160	JLK 85-630	26
ISO2117	ISO 100M16 UL	60	ITB1010	ITB 80-15 W	83	JLK1165	JLK 85-730	26
ISO2120	CLN 16M4-20	61	ITB1025	ITB 80-15 B	83	JLK1170	JLK 85-830	26
ISO2125	CLN 16M5-20	61	ITB1040	ITB 80-15 G	83	JLK1175	JLK 85-930	26
ISO2130	CLN 16M6-20	61	ITB2000	ITB-S DIN35	83	JLK1180	JLK 85-1030	26
ISO2135	CLN 20M5-20	61	JLK			JLK5000	JLP 25-230	28
ISO2140	CLN 20M6-20	61	JLK1000	JLK 25-230	26	JLK5005	JLP 25-330	28
ISO2145	CLN 25M4-20	61	JLK1005	JLK 25-330	26	JLK5010	JLP 25-430	28
ISO2150	CLN 25M5-20	61	JLK1010	JLK 25-430	26	JLK5015	JLP 25-530	28
ISO2155	CLN 25M6-20	61	JLK1015	JLK 25-530	26	JLK5020	JLP 25-630	28
ISO2160	CLN 25M8-20	61	JLK1020	JLK 25-630	26	JLK5021	JLP 25-730	28
ISO2165	CLN 30M5-20	61	JLK1021	JLK 25-730	26	JLK5022	JLP 25-830	28
ISO2170	CLN 30M6-20	61	JLK1022	JLK 25-830	26	JLK5023	JLP 25-930	28
ISO2175	CLN 30M8-20	61	JLK1023	JLK 25-930	26	JLK5024	JLP 25-1030	28
ISO2180	CLN 35M5-20	61	JLK1024	JLK 25-1030	26	JLK5025	JLP 35-230	28
ISO2185	CLN 35M6-20	61	JLK1025	JLK 35-230	26	JLK5030	JLP 35-330	28
ISO2190	CLN 35M8-20	61	JLK1030	JLK 35-330	26	JLK5035	JLP 35-430	28
ISO2195	CLN 40M5-20	61	JLK1035	JLK 35-430	26	JLK5040	JLP 35-530	28
ISO2200	CLN 40M6-20	61	JLK1040	JLK35-530	26	JLK5045	JLP 35-630	28
ISO2205	CLN 40M8-20	61	JLK1045	JLK 35-630	26	JLK5046	JLP 35-730	28
ISO2210	CLN 45M5-20	61	JLK1046	JLK 35-730	26	JLK5047	JLP 35-830	28
ISO2215	CLN 45M6-20	61	JLK1047	JLK 35-830	26	JLK5048	JLP 35-930	28
ISO2220	CLN 45M8-20	61	JLK1048	JLK 35-930	26	JLK5049	JLP 35-1030	28
ISO2225	CLN 50M5-20	61	JLK1049	JLK 35-1030	26	JLK5050	JLP 50-230	28
ISO2230	CLN 50M6-20	61	JLK1050	JLK 50-230	26	JLK5055	JLP 50-330	28
ISO2235	CLN 50M8-20	61	JLK1055	JLK 50-330	26	JLK5060	JLP 50-430	28
ISO2240	CLN 30M6-30	61	JLK1060	JLK 50-430	26	JLK5065	JLP 50-530	28
ISO2245	CLN 30M8-30	61	JLK1065	JLK 50-530	26	JLK5070	JLP 50-630	28
ISO2250	CLN 35M6-30	61	JLK1070	JLK 50-630	26	JLK5071	JLP 50-730	28
ISO2255	CLN 35M8-30	61	JLK1071	JLK 50-730	26	JLK5072	JLP 50-830	28
ISO2256	CLN 40M6-30	61	JLK1072	JLK 50-830	26	JLK5073	JLP 50-930	28
ISO2257	CLN 40M8-30	61	JLK1073	JLK 50-930	26	JLK5074	JLP 50-1030	28
ISO2260	CLN 45M6-30	61	JLK1074	JLK 50-1030	26	JLK5075	JLP 120-330	28
ISO2265	CLN 45M8-30	61	JLK1075	JLK 120-330	26	JLK5080	JLP 120-430	28
ISO2266	CLN 50M6-30	61	JLK1080	JLK 120-430	26	JLK5085	JLP 120-530	28
ISO2267	CLN 50M8-30	61	JLK1085	JLK 120-530	26	JLK5090	JLP 120-630	28
ISO2270	CLN 55M6-30	61	JLK1090	JLK 120-630	26	JLK5095	JLP 120-730	28
ISO2275	CLN 55M8-30	61	JLK1095	JLK 120-730	26	JLK5096	JLP 120-830	28
ISO2280	CLN 65M6-30	61	JLK1096	JLK 120-830	26	JLK5097	JLP 120-930	28
ISO2285	CLN 65M8-30	61	JLK1097	JLK 120-930	26	JLK5098	JLP 120-1030	28
ISO2290	CLN 70M6-30	61	JLK1098	JLK 120-1030	26	JLK5100	JLP 240-330	28
ISO2295	CLN 70M8-30	61	JLK1099	JLK 240-330	26	JLK5105	JLP 240-430	28
ISO3000	ISO PM5x20	62	JLK1100	JLK 240-330	26	JLK5110	JLP 240-530	28

Code	Riferimento	Pagina
JLK5115	JLP 240-630	28
JLK5120	JLP 240-730	28
JLK5125	JLP 240-830	28
JLK5130	JLP 240-930	28
JLK5135	JLP 240-1030	28
JLK5140	JLP 85-230	28
JLK5145	JLP 85-330	28
JLK5150	JLP 85-430	28
JLK5155	JLP 85-530	28
JLK5160	JLP 85-630	28
JLK5165	JLP 85-730	28
JLK5170	JLP 85-830	28
JLK5175	JLP 85-930	28
JLK5180	JLP 85-1030	28

MCR		
MCR1000	MCR 5x16	42
MCR1005	MCR 5x35	42
MCR1010	MCR 5x70	42
MCR1015	MCR 5x120	42
MCR1017	MCR 5x185	42
MCR1020	MCR 10x16	42
MCR1025	MCR 10x35	42
MCR1030	MCR 10x70	42
MCR1035	MCR 10x120	42
MCR1037	MCR 10x185	42
MCR1100	MCR 4xM5	42
MCR2000	MCR 4x12	42

MRS		
MRS1501	MRS 9x6	85
MRS1506	MRS 12x8	85
MRS2000	MRS 13-6-20	86
MRS3000	MRS 2x6	87
MRS3005	MRS 2x12	87
MRS3010	MRS 2x24	87
MRS3500	MRS 2x41	87
MRS4000	MRS 12X8-14	85
MRS4005	MRS 12X8-28	85
MRS4010	MRS 12X8-42	85
MRS5000	MRS 13-6-50	86
MRS5002	MRS 13-6-41	86
MRS5005	MRS 13-6-56	86
MRS7000	MRS-S 9x6	87
MRS7005	MRS-S 12x8	87
MRS7010	MRS-S 9x19	87

PBF		
PBF1060	PBF 3X20-M6	22
PBF1065	PBF 4X20-M8	22
PBF1090	PBF 3X24-M8	22
PBF1100	BF 5X24-M10	22
PBF1125	BF 3X32-M10	22
PBF1140	BF 6X32-M12	22
PBF1165	BF 4X40-M12	22
PBF1180	BF 8X40-80	22

Code	Riferimento	Pagina
PBF1195	BF 4X50-40	22
PBF1210	BF 8X50-80	22
PBF1225	BF 4X63-40	22
PBF1240	BF 8X63-80	22
PBF1255	BF 4X80-50	22
PBF1270	BF 8X80-100	22

PBM		
PBM1000	PBM 100x100	43
PBM2000	RBM M6	43
PBM2005	RBM M8	43
PBM2010	RBM M10	43
PBM2015	RBM M12	43

PRP		
PRP0990	PRP 12x4	39
PRP1000	PRP 20x5	39
PRP1005	PRP 25x5	39
PRP1010	PRP 30x5	39
PRP1015	PRP 40x5	39
PRP1020	PRP 50x5	39
PRP1025	PRP 60x5	39
PRP1030	PRP 80x5	39
PRP1035	PRP 100x5	39
PRP1040	PRP 125x5	39
PRP1045	PRP 30x10	39
PRP1050	PRP 40x10	39
PRP1055	PRP 50x10	39
PRP1060	PRP 60x10	39
PRP1065	PRP 80x10	39
PRP1070	PRP 100x10	39
PRP1075	PRP 120x10	39
PRP1080	PRP 160x10	39
PRP1085	PRP 200x10	39
PRP2000	PRP 20x5x1750	39
PRP2005	PRP 25x5x1750	39
PRP2010	PRP 30x5x1750	39
PRP2015	PRP 40x5x1750	39
PRP2020	PRP 50x5x1750	39
PRP2025	PRP 60x5x1750	39
PRP2030	PRP 80x5x1750	39
PRP2035	PRP 100x5x1750	39
PRP2040	PRP 125x5x1750	39
PRP2045	PRP 30x10x1750	39
PRP2050	PRP 40x10x1750	39
PRP2055	PRP 50x10x1750	39
PRP2060	PRP 60x10x1750	39
PRP2065	PRP 80x10x1750	39
PRP2070	PRP 100x10x1750	39
PRP2075	PRP 120x10x1750	39
PRP2990	PRP 12x4x1750	39

PSP		
PSP1000	PSP 250	64
PSP1002	PSP 250 HP	64

Code	Riferimento	Pagina
PSP1005	PSP 400	64
PSP1010	PSP 630T	64
PSP1015	PSP PRO 630T	65
PSP1020	PSP 630TN	64
PSP1025	PSP PRO 630TN	65
PSP1030	PSP 160K-23	66
PSP1032	PSP 160K-32	66
PSP1035	PSP 250K-23	66
PSP1036	PSP 250K-31	66
PSP1038	PSP 250K-42	66
PSP1040	PSP 400K-30	67
PSP1050	PSP 400K-48	67
PSP1065	PSP 630K-45	67
PSP1070	PSP 630K-55	67

PTB		
PTB6015	PTB 125	82
PTB6020	PTB 160	82
PTB6025	PTB 250	82
PTB6030	PTB 400	82

RPB		
RPB0990	RPB 40-08	70
RPB0995	RPB 80-07	70
RPB1000	RPB 125-06	70
RPB1005	RPB 125-14	70

RPC		
RPC3000	RPC 125A	79
RPC3005	RPC 160A	79
RPC3010	RPC 250A	79
RPC3015	RPC 400A	79
RPC3020	RPC 500A	79

RPQ		
RPQ0980	RPQ 40-08	71
RPQ0985	RPQ 40-14	71
RPQ0990	RPQ 80-07	71
RPQ0995	RPQ 80-12	71
RPQ1000	RPQ 125-06	71
RPQ1005	RPQ 125-10	71
RPQ1010	RPQ 125-14	71
RPQ1015	RPQ 160-11	72
RPQ1016	RPQ 160-11 U&D	72
RPQ1017	RPQ 160-11 MS	72
RPQ1018	RPQ 160-11 SI	72
RPQ1025	RPQ C-125	74
RPQ1050	RPQ 400-14	75
RPQ2017	RPN 160-14	73

RPT		
RPT3000	RPT 125-6 S	78
RPT3005	RPU 160-6 S	78

RPU		
RPU2995	RPU 80-6 S	76
RPU3000	RPU 125-8 S	76

Code	Riferimento	Pagina
RPU3005	RPU 160-8 S	76
RPU3010	RPU 250-11 S	76
RPU3015	RPU 400-11 S	76
RPU3020	RPU 500-11	77
RPU5000	RPU 80-S-14-B	80
RPU5005	RPU 80-S-14-G	80
RPU5010	RPB 80-S-7-BG	80

SBQ		
SBQ1000	SBQ 30X30	43
SBQ1005	SBQ 40X40	43
SBQ1010	SBQ 50X50	43
SBQ1015	SBQ 63X63	43
SBQ1020	SBQ 80X80	43
SBQ1025	SBQ 100X100	43

SBR		
SBR1000	SBR 50x24	43
SBR1005	SBR 50x32	43
SBR1010	SBR 50x40	43
SBR1015	SBR 80x24	43
SBR1020	SBR 80x32	43
SBR1025	SBR 80x50	43

SCH		
SCH1000	SCH 1000x2000x3	65
SCH1005	SCH 1000x215x3	65
SCH1010	SCH 1000x150x3	65

TFP		
TFP1000	TFP M5	100
TFP1005	TFP M6	100

TMP		
TMP1010	TMP M5	100
TMP1015	TMP M6	100

TMS		
TMS1000	TMS 6-150-6	33
TMS1005	TMS 6-200-6	33
TMS1010	TMS 10-150-8	33
TMS1015	TMS 10-200-8	33
TMS1020	TMS 10-250-8	33
TMS1025	TMS 10-300-8	33
TMS1030	TMS 16-100-8	33
TMS1035	TMS 16-150-8	33
TMS1040	TMS 16-200-8	33
TMS1045	TMS 16-250-8	33
TMS1050	TMS 16-300-8	33
TMS1055	TMS 25-150-10	33
TMS1060	TMS 25-200-10	33
TMS1065	TMS 25-250-10	33
TMS1070	TMS 25-300-10	33
TMS1075	TMS 35-150-10	33
TMS1080	TMS 35-200-10	33
TMS1085	TMS 35-250-10	33
TMS1090	TMS 35-300-10	33
TMS1095	TMS 50-100-10	33

Code	Riferimento	Pagina
TMS1100	TMS 50-150-10	33
TMS1105	TMS 50-200-10	33
TMS1110	TMS 50-250-10	33
TMS1115	TMS 50-300-10	33
TMS1120	TMS 75-200-10	33
TMS1125	TMS 75-250-10	33
TMS1130	TMS 75-300-10	33
TMS1135	TMS 100-200-12	33
TMS1140	TMS 100-250-12	33
TMS1145	TMS 100-300-12	33

TMT		
TMT1200	TMT 6-150-6	33
TMT1205	TMT 6-200-6	33
TMT1210	TMT 10-300-6	33

TOP		
TOP1000	TOP PR2000	46
TOP1005	TOP 2/5T	46
TOP1010	TOP 2/5TN	46
TOP1015	TOP 4/5T	46
TOP1020	TOP 4/5TN	46
TOP1025	TOP 1/10T	46
TOP1030	TOP 1/10TN	46
TOP1035	TOP 2/10T	46
TOP1040	TOP 2/10TN	46
TOP1045	TOP 3/10T	46
TOP1050	TOP 3/10TN	46
TOP1052	TOP 4/10T	47
TOP1053	TOP 4/10TN	47
TOP1055	TOP TI	47
TOP1060	TOP 2/5TN-400	47
TOP1065	TOP 1/10TN-400	47
TOP1070	TOP 2/5TN-600	47
TOP1075	TOP 2/10TN-600	47
TOP1100	TOP SQ-O	47
TOP1105	TOP SQ-V	47
TOP2000	TOP J -5-10	53

TPI		
TPI1000	TPI 20-16	35
TPI1005	TPI 20-25	35
TPI1010	TPI 20-35	35
TPI1015	TPI 20-50	35

TPR		
TPR1000	TPR 10-4	34
TPR1005	TPR 10-6	34
TPR1010	TPR 20-10	34
TPR1015	TPR 20-16	34
TPR1020	TPR 20-25	34
TPR1021	TPR 20-30	34
TPR1025	TPR 20-35	34
TPR1026	TPR 20-40	34
TPR1030	TPR 20-50	34
TPR1035	TPR 20-75	34
TPR1040	TPR 20-100	34

Code	Riferimento	Pagina
TPR1045	TPR 20-120	34

TPS		
TPS1000	TPS 10-4	34
TPS1005	TPS 10-6	34
TPS1010	TPS 20-10	34
TPS1015	TPS 20-16	34
TPS1020	TPS 20-25	34
TPS1025	TPS 20-30	34
TPS1030	TPS 20-35	34
TPS1035	TPS 20-40	34
TPS1040	TPS 20-50	34
TPS1045	TPS 20-75	34
TPS1050	TPS 20-100	34
TPS1055	TPS 20-120	34

TSC		
TSC1000	TSC 4	35
TSC1005	TSC 10	35
TSC1010	TSC 16	35
TSC1015	TSC 25	35
TSC1020	TSC 35	35
TSC1025	TSC 50	35

TTI		
TTI1000	TTI 20-16	35
TTI1005	TTI 20-25	35
TTI1010	TTI 20-35	35

TTR		
TTR1000	TTR 10-6	34
TTR1005	TTR 20-10	34
TTR1010	TTR 20-16	34
TTR1015	TTR 20-25	34
TTR1020	TTR 20-35	34
TTR1025	TTR 20-50	34
TTR1030	TTR 20-100	34

TTS		
TTS1000	TTS 10-6	34
TTS1005	TTS 20-10	34
TTS1010	TTS 20-16	34
TTS1015	TTS 20-25	34
TTS1020	TTS 20-35	34
TTS1025	TTS 20-50	34
TTS1030	TTS 20-100	34

UBF		
UBF1005	UPB-T-BFX	23
UBF1010	UFB-BFX	23

UTD		
UTD3005	UTD T-P 03	97

UTG		
UTG1000	UTG T	93
UTG1001	UTG M	93
UTG1500	UTG T-L	93
UTG1501	UTG M-L	93

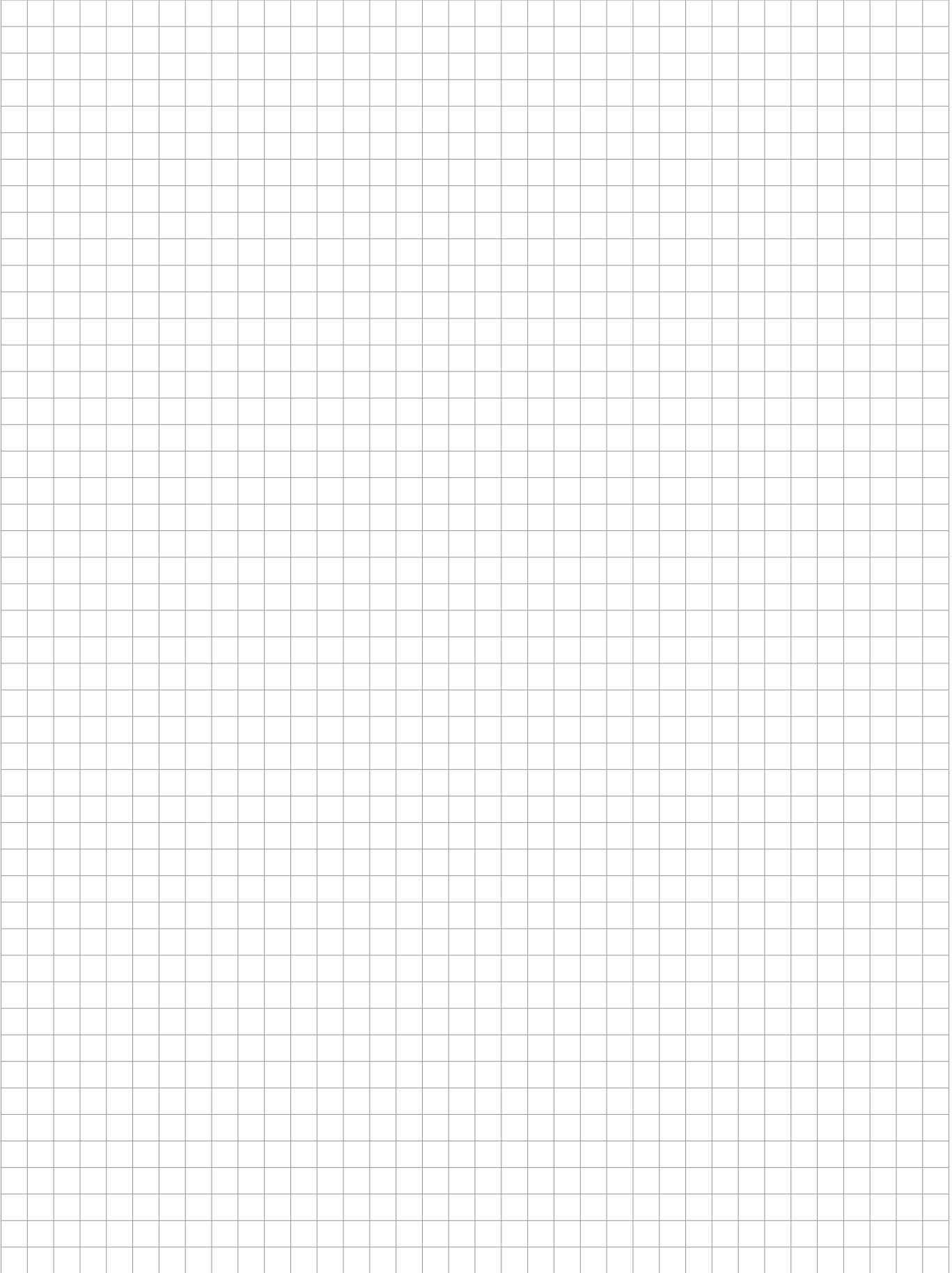

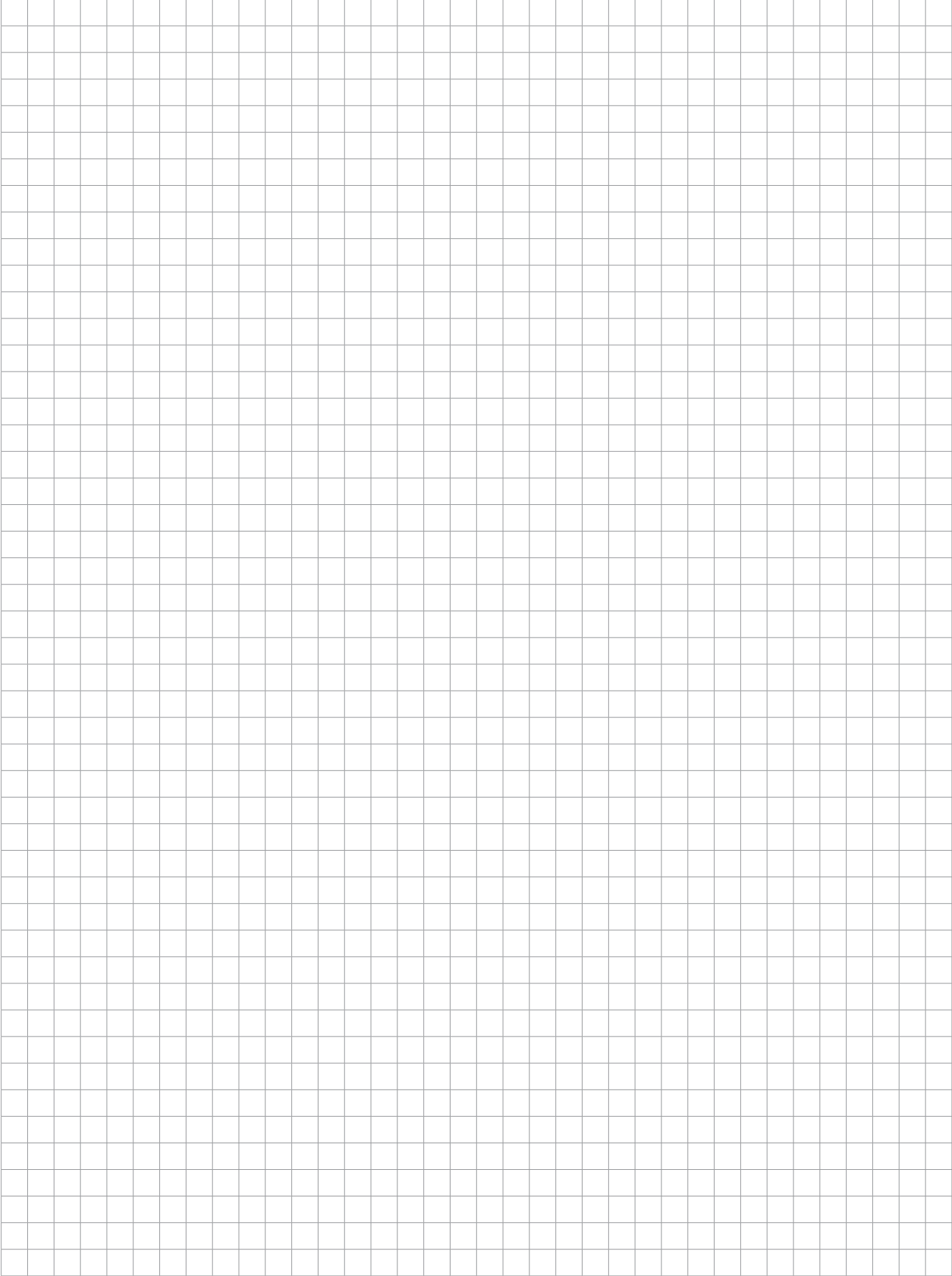

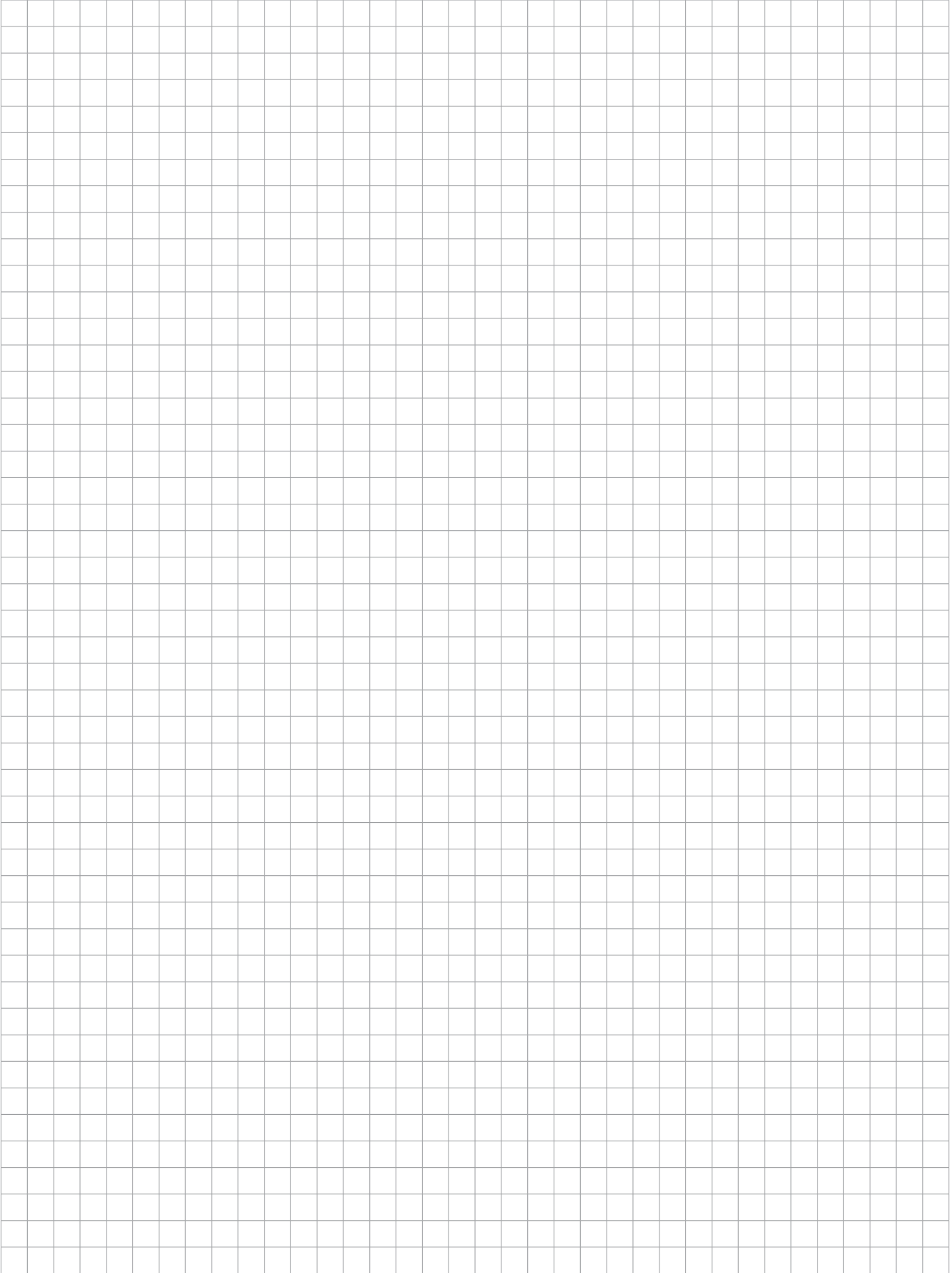



NOTE

A large grid of graph paper for taking notes, consisting of 20 columns and 30 rows of small squares.



Headquarter and Logistic Center Milan (IT)
www.teknomega.it



Manufacturing plant Piacenza (IT)
www.teknomega.it

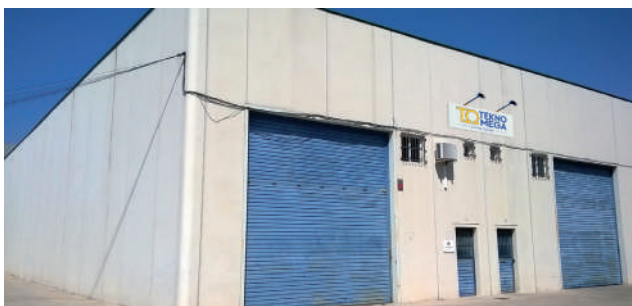

Spanish Branch Barcelona (ES)
www.teknomega.es



FASTENING SOLUTIONS FOR PHOTOVOLTAIC PANELS

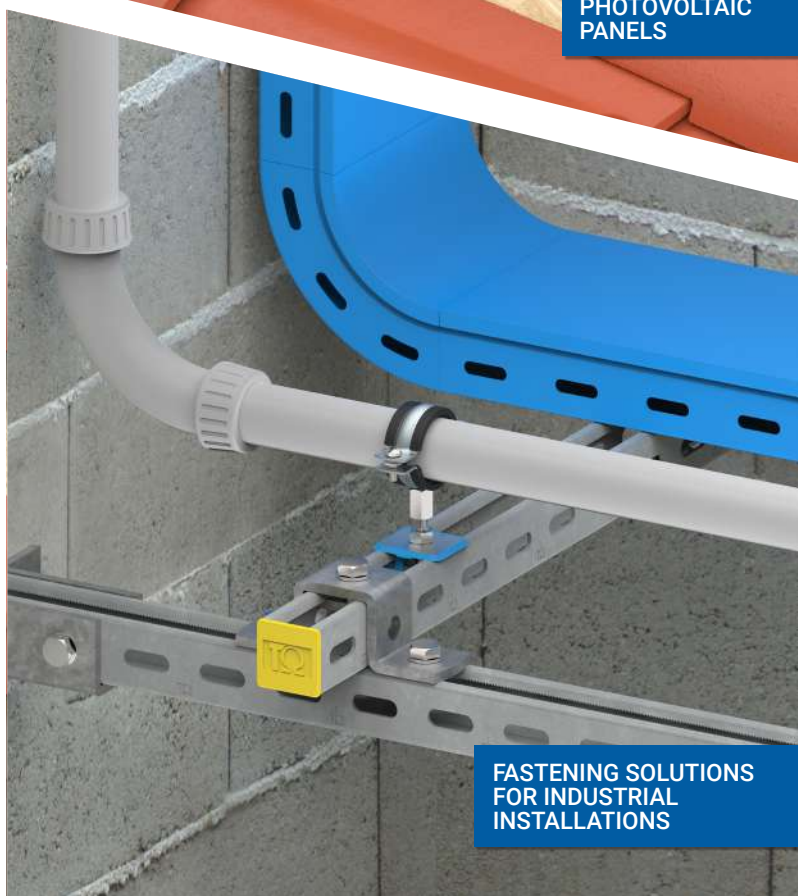

FASTENING SOLUTIONS FOR INDUSTRIAL INSTALLATIONS

Request our catalogue at:
info@teknomega.it



TEKNOMEGA S.r.l.
Via Archimede, 1 | 20094 Corsico (MI)
Tel.: +39-0248844281
info@teknomega.it - www.teknomega.it



Teknomega s.r.l.

Via Archimede, 1 - 20094 Corsico (MI)

Tel. +39 02 48844281

e-mail: info@teknomega.it

www.teknomega.it

Vat nb: IT 04232250961

